

PLANS FOR CONSTRUCTION

EAST REEDLEY BRIDGE REPLACEMENTS

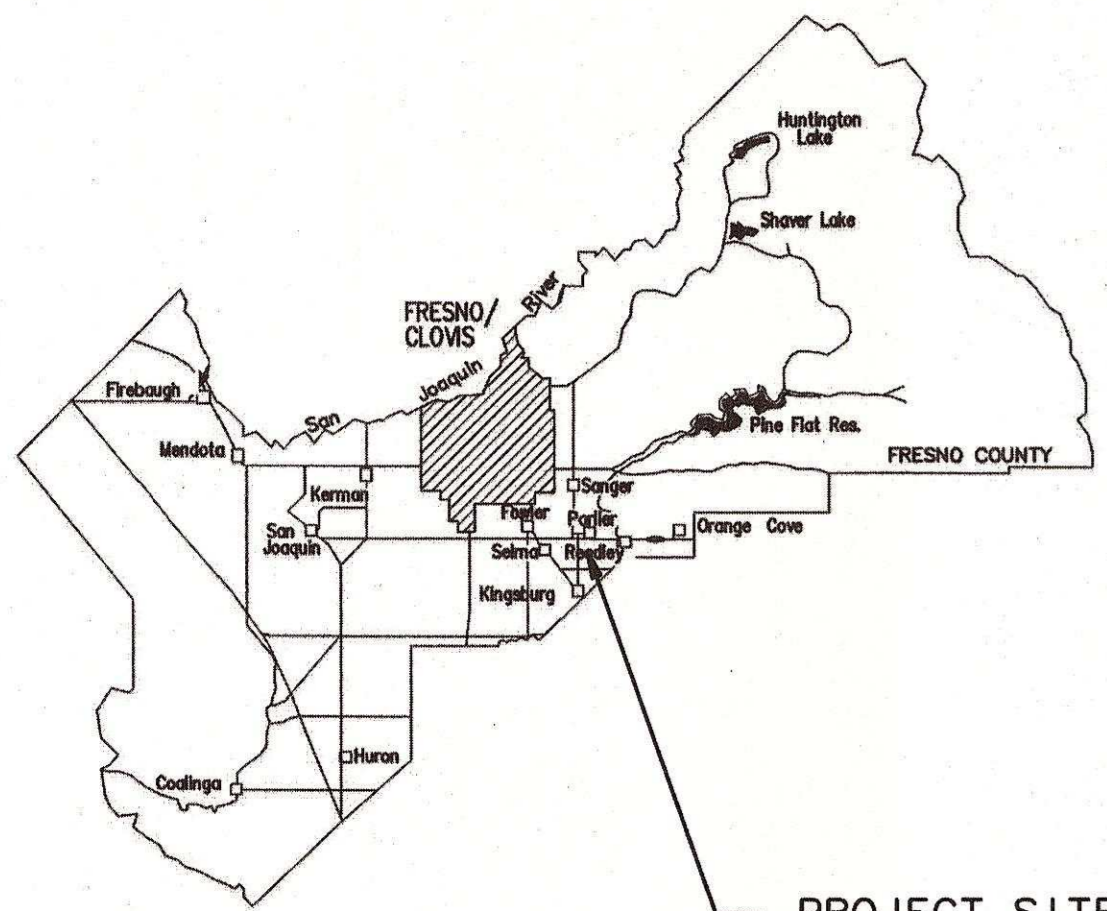

PROJECT SITE

**REEDLEY MAIN CANAL
BRIDGE REPLACEMENT
ON ENGLEHART AVENUE**
FEDERAL PROJECT No. BRLO-5942(239) PROJECT LENGTH 0.09 MI.

**TRAVERS CREEK BRIDGE
REPLACEMENT ON
LINCOLN AVENUE**
FEDERAL PROJECT No. BRLO-5942(226) PROJECT LENGTH 0.11 MI.

**TRAVERS CREEK BRIDGE
REPLACEMENT ON
PARLIER AVENUE**
FEDERAL PROJECT No. BRLO-5942(227) PROJECT LENGTH 0.06 MI.

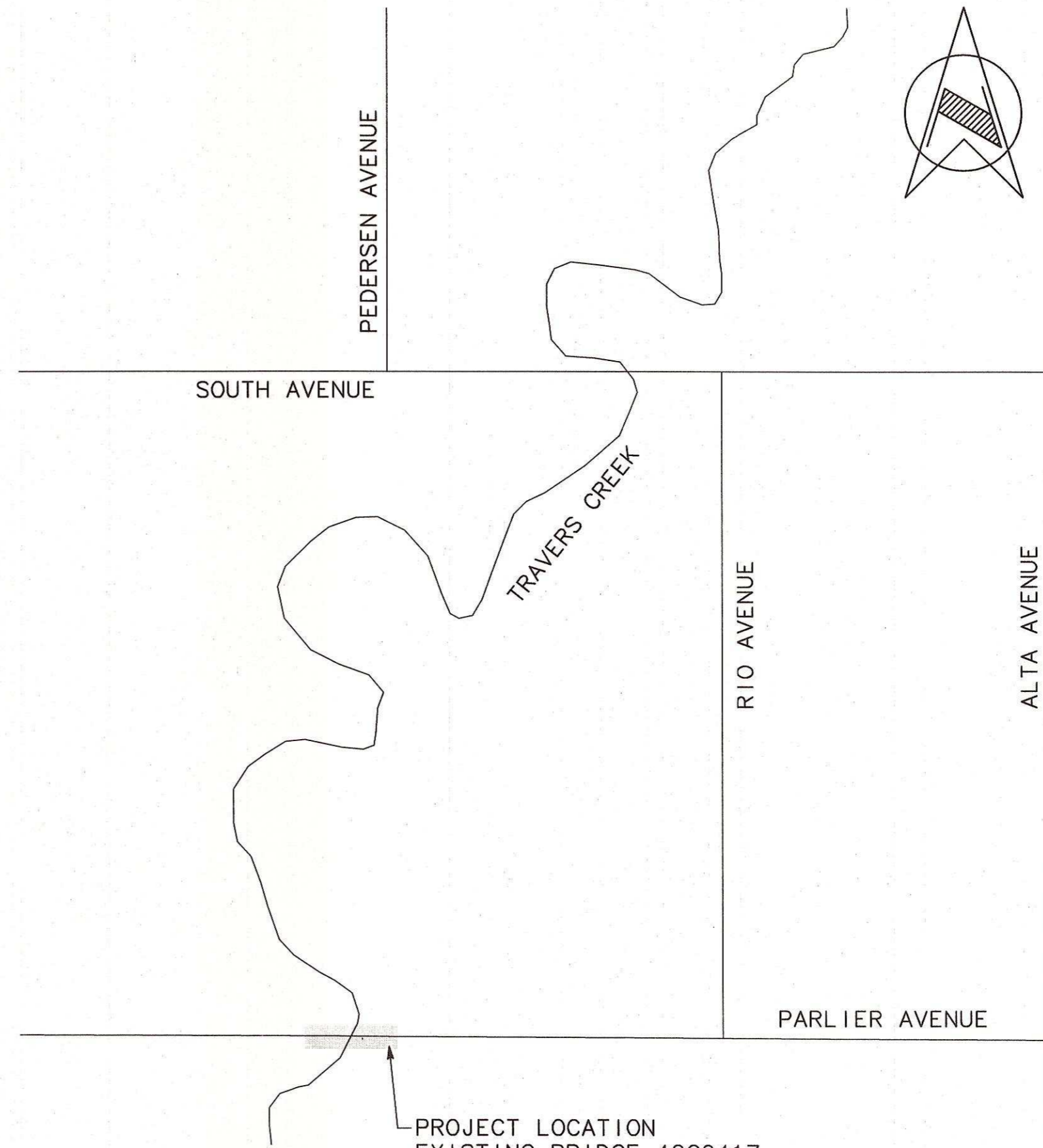
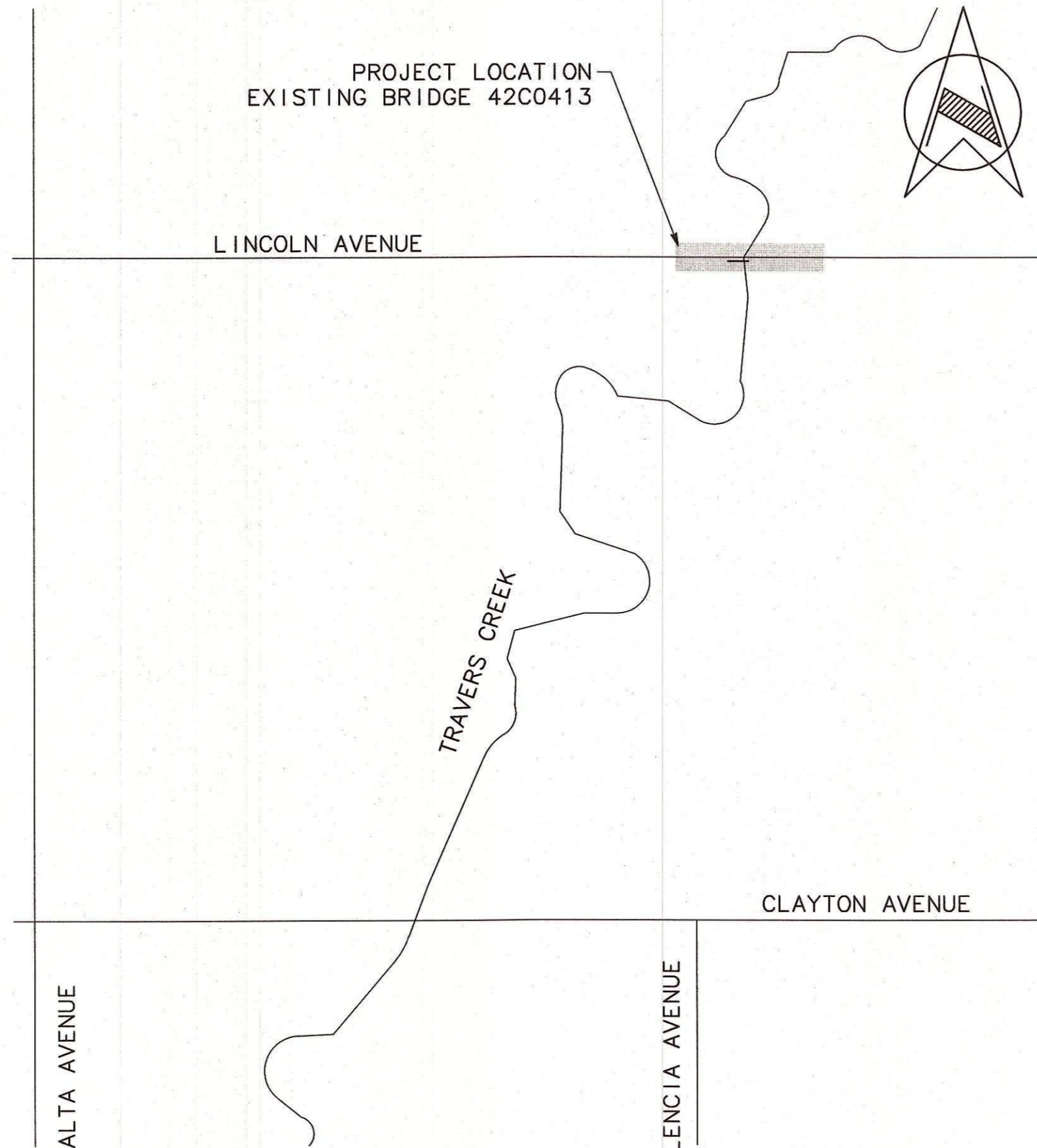
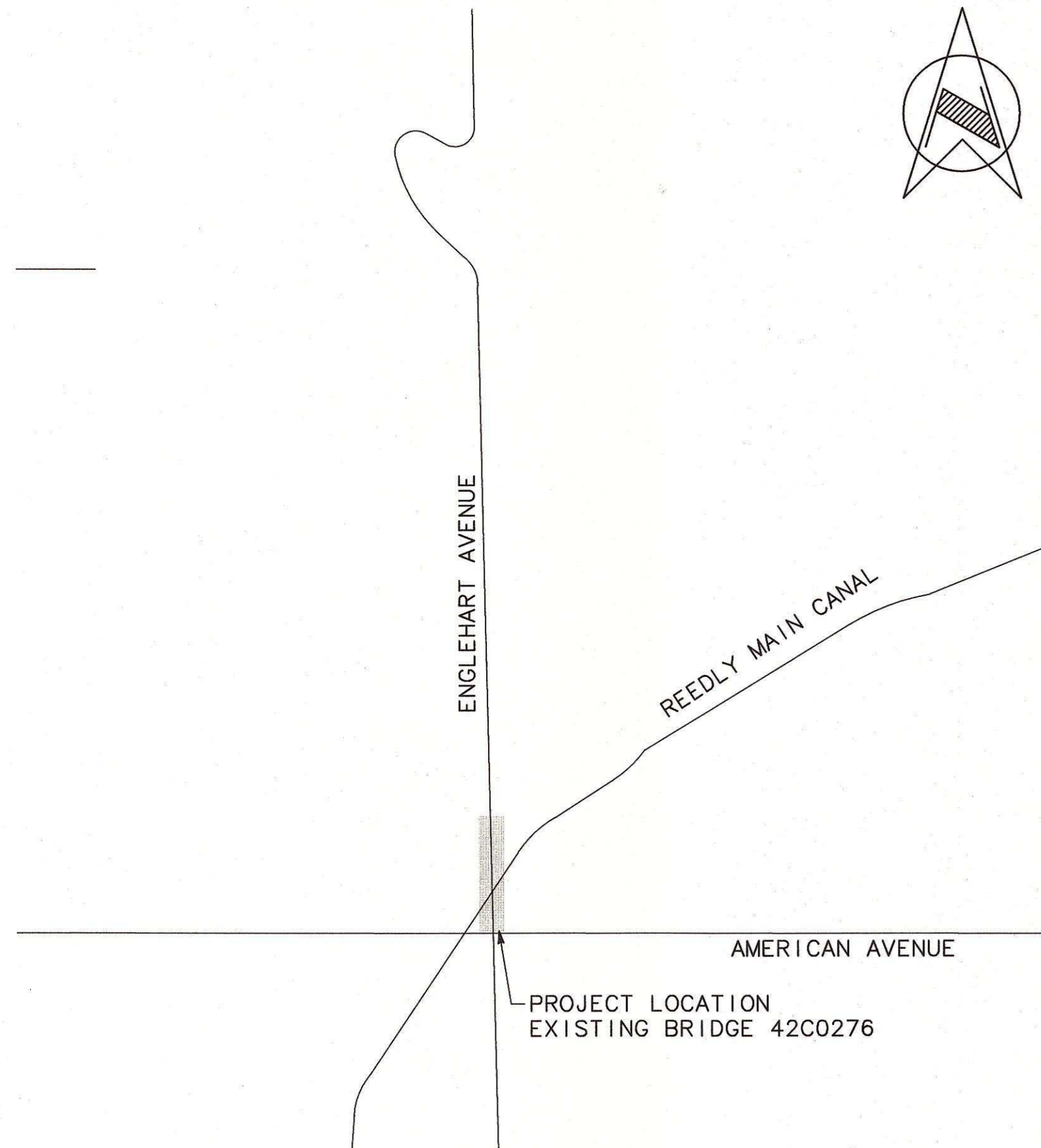

DIVISION	DESIGN	CONST	RMO
SIGNATURE	<i>[Signature]</i>	<i>[Signature]</i>	<i>[Signature]</i>
DATE	6/13/2024	6/17/2024	6/17/2024



DEPARTMENT OF PUBLIC WORKS AND PLANNING

INDEX OF SHEETS

No.	Sheet	Title
1.	T-1	TITLE PAGE
2.	S-1	STRUCTURAL GENERAL NOTES
REEDLEY MAIN CANAL BRIDGE REPLACEMENT ON ENGLEHART AVENUE		
3.	X-1	REEDLEY MAIN CANAL TYPICAL SECTIONS
4.	PC-1	REEDLEY MAIN CANAL PROJECT CONTROLS
5.	PP-1	REEDLEY MAIN CANAL PLAN AND PROFILE
6.	CD-1	REEDLEY MAIN CANAL CONSTRUCTION DETAILS
7.	CD-2	REEDLEY MAIN CANAL CONSTRUCTION DETAILS
8.	U-1	REEDLEY MAIN CANAL UTILITY PLAN
9.	SS-1	REEDLEY MAIN CANAL SIGNING AND STRIPING PLAN
10.	TD-1	REEDLEY MAIN CANAL TRAFFIC DETOUR PLAN
11.	S-2	REEDLEY MAIN CANAL GENERAL LAYOUT
12.	S-3	REEDLEY MAIN CANAL FOUNDATION PLAN
13.	S-4	REEDLEY MAIN CANAL BOX CULVERT DETAILS
TRAVERS CREEK BRIDGE REPLACEMENT ON LINCOLN AVENUE		
14.	X-2	TRAVERS CREEK AT LINCOLN AVE TYPICAL SECTIONS
15.	PC-2	TRAVERS CREEK AT LINCOLN AVE PROJECT CONTROL
16.	PP-2	TRAVERS CREEK AT LINCOLN AVE PLAN AND PROFILE
17.	CD-3	TRAVERS CREEK AT LINCOLN AVE CONSTRUCTION DETAILS
18.	CD-4	TRAVERS CREEK AT LINCOLN AVE ROCK SLOPE PROTECTION DETAILS
19.	U-2	TRAVERS CREEK AT LINCOLN AVE UTILITY PLAN
20.	SS-2	TRAVERS CREEK AT LINCOLN AVE SIGNING AND STRIPING PLAN
21.	TD-2	TRAVERS CREEK AT LINCOLN AVE TRAFFIC DETOUR PLAN
22.	D-1	TRAVERS CREEK AT LINCOLN AVE DRAINAGE
23.	S-5	TRAVERS CREEK AT LINCOLN AVE GENERAL LAYOUT
24.	S-6	TRAVERS CREEK AT LINCOLN AVE FOUNDATION PLAN
25.	S-7	CIP BOTTOMLESS CULVERT DETAILS
26.	S-8	BOTTOMLESS CULVERT GENERAL CONFIGURATIONS
27.	S-9	CIP BOTTOMLESS CULVERT WALL, SLAB, & PILE DETAILS
28.	S-10	CIP BOTTOMLESS CULVERT FOUNDATION DETAILS
29.	S-11	CIP BOTTOMLESS CULVERT FOOTINGS ON SOIL
TRAVERS CREEK BRIDGE REPLACEMENT ON PARLIER AVENUE		
30.	X-3	TRAVERS CREEK AT PARLIER AVE TYPICAL SECTIONS
31.	PC-3	TRAVERS CREEK AT PARLIER AVE PROJECT CONTROL
32.	PP-3	TRAVERS CREEK AT PARLIER AVE PLAN AND PROFILE
33.	CD-5	TRAVERS CREEK AT PARLIER AVE CONSTRUCTION DETAILS
34.	CD-6	TRAVERS CREEK AT PARLIER AVE ROCK SLOPE PROTECTION DETAILS
35.	U-3	TRAVERS CREEK AT PARLIER AVE UTILITY PLAN
36.	SS-3	TRAVERS CREEK AT PARLIER AVE SIGNING AND STRIPING PLAN
37.	TD-3	TRAVERS CREEK AT PARLIER AVE TRAFFIC DETOUR PLAN
38.	S-12	TRAVERS CREEK AT PARLIER AVE GENERAL LAYOUT
39.	S-13	TRAVERS CREEK AT PARLIER AVE FOUNDATION PLAN
40.	S-14	TRAVERS CREEK AT PARLIER AVE BOX CULVERT DETAILS

Adopted by the County of Fresno Board of Supervisors

_____, 20____

Nathan Magsig	Chairman	5rd District
Buddy Mendes	Vice Chairman	4th District
Brian Pacheco		1st District
Steve Brandau		2nd District
Sal Quintero		3th District

APPROVED

[Signature]
Steven E. White, Director
Department of Public Works and Planning

CONTRACTOR'S LICENSING REQUIREMENT					
CLASS A, GENERAL ENGINEERING					
C-12, EARTHWORK AND PAVING					
Drawing No.	Road No.	Bridge No.	Fiscal Yr.	Sheet No.	Total
11309	2809, 4721, 6263	42C0708, 42C0683, 42C0684	2024-2025	1	40
Contract No. 24-07-C					
RECORD DRAWING					
NAME _____					
ADDRESS _____					
CITY _____ STATE _____ ZIP _____					
PHONE _____					
DATE AWARDED _____					
DATE STARTED _____					
DATE COMPLETED _____					
RESIDENT ENGINEER					
NAME _____ SIGNATURE _____					
NAME _____ SIGNATURE _____					

GENERAL NOTES

- See Road Plans for additional details and notes not shown.
- The contractor shall verify all existing field conditions, layout, dimensions and coordination with road drawings prior to start of construction or ordering or fabricating any material. Any discrepancies shall be immediately brought to the attention of the Engineer.
- The contractor will be responsible for conforming to the applicable Construction Safety Orders of the Division of Industrial Safety of the State of California and OSHA requirements.
- Weakened planes shall be placed perpendicular to the box culvert wall. Joints in walls and top slab shall match.
- See Road Plans for elevation control.

DESIGN NOTES

Design: AASHTO LRFD Bridge Design Specifications, 6th Edition, and corresponding CALTRANS Amendments

Dead Load: Includes 35 psf for future AC Overlay

Live Loading: HL93 & Permit Design Load

Impact: Applied to roof slab only
 $IM = 33(1.0 - 0.125D_e) \geq 0\%$ (AASHTO LRFD 3.6.2.2)
 D_e = minimum depth of earth cover

Reinforced Concrete: $f'_c = 3,600$ psi at 28 days
 $f_y = 60,000$ psi

AID GENERAL NOTES

- Contractors shall comply with Business and Professions Code Section 8771(b) regarding referencing, preserving, and reconstructing monuments, whether or not monuments are shown in these plans.
- Contractor shall provide the engineer a minimum of (2) weeks notice prior to commencing any work that could damage or destroy any survey monuments.
- If monument is damaged by construction operations the contractor shall replace at the contractors cost.
- All works shall conform with the standards and requirements shown on the project plans and specifications.
- All material shall be new and no salvaged material or previously used material may be used unless approved by the district's engineer.
- All disturbed soil and pipe bedding shall be compacted to a minimum of 90% maximum density. contractor shall be responsible for compaction tests and all test shall be provided to the District's engineer.
- All bends and/or elbows shown are precast unless specified differently and shall conform to ASTM standards.
- All excess material and/or debris shall be removed upon completion of the installation.
- Construction shall not interfere with the flow or distribution of water as required by the district. all improvements shall be construction in a manner to allow flood flows to pass at all times.
- The contractor shall be responsible for any water that may flow in the irrigation facility or area of construction during the time of installation.
- Alta Irrigation District, (559)591-0800, shall be notified to determine a time period that work may be performed.
- Alta Irrigation District, (559)591-0800, shall be notified 48 hours prior to construction. no work shall begin without written permission of Alta Irrigation District's general manager.
- All irrigation pipe installed for use by the District shall be inspection approved by the District's field inspector before backfilling may occur.
- Pipe shall be bedded in sand from 3 inches below the pipe to 1 foot above the tope of pipe.
- Locator taped marked, "caution irrigation pipeline buried below." shall be laid on top of the sand bedding.
- All encroachments (including tree selection) within the Alta Irrigation District's easement shall be approved by the District.
- Pipeline and appurtenances are to be installed according to the details and elevations shown on the plans approved by the District.
- Alta irrigation district pipeline shall be a minimum of RGRCP class 3 spun pipeline. the class shall be upgraded if required by the site conditions.
- An encroachment permit will be required for all utility crossings within the Alta Irrigation District right-of-way.

GEOTECHNICAL DESIGN PARAMETERS

Reedley Main Canal Bridge at Englehart Avenue
 Per the Foundation Report dated September 9, 2016 prepared by Technicon:

Reinforced Concrete Boxes:
 Earth pressure for two conditions:
 140 pcf vertical; 42 pcf horizontal
 140 pcf vertical; 140 pcf horizontal

Service Limit State Permissible Net Contact Stress = 5,100 psf
 Strength Limit State Factored Gross Nominal Bearing Resistance = 11,300 psf

Retaining Walls:
 Soil Unit Weight = 140 pcf
 Lateral "active" equivalent fluid pressure (drained) = 36 pcf
 Seismic increment = 16 pcf
 Nominal passive pressure = 250 pcf
 Nominal coefficient of friction = 0.56
 Horizontal Live Load Surcharge = 2 feet

Travers Creek at Lincoln Avenue
 Per the Foundation Report dated September 9, 2016 prepared by Technicon:

Reinforced Concrete Bottomless Culvert:
 Earth pressure for two conditions:
 140 pcf vertical; 42 pcf horizontal
 140 pcf vertical; 84.4 pcf horizontal

Service Limit State Permissible Net Contact Stress = 11,500 psf
 Strength Limit State Factored Gross Nominal Bearing Resistance = 8,000 psf

Retaining Walls:
 Soil Unit Weight = 140 pcf
 Lateral "active" equivalent fluid pressure (drained) = 39 pcf
 Seismic increment = 16.5 pcf
 Nominal passive pressure = 290 pcf
 Nominal coefficient of friction = 0.56
 Horizontal Live Load Surcharge = 2 feet

Travers Creek at Parlier Avenue
 Per the Foundation Report dated September 21, 2016 prepared by Technicon:

Reinforced Concrete Boxes:
 Earth pressure for two conditions:
 140 pcf vertical; 42 pcf horizontal
 140 pcf vertical; 140 pcf horizontal

Service Limit State Permissible Net Contact Stress = 4,270 psf
 Strength Limit State Factored Gross Nominal Bearing Resistance = 5,000 psf

Retaining Walls:
 Soil Unit Weight = 140 pcf
 Lateral "active" equivalent fluid pressure (drained) = 40.5 pcf
 Seismic increment = 17.5 pcf
 Nominal passive pressure = 260 pcf
 Nominal coefficient of friction = 0.54
 Horizontal Live Load Surcharge = 2 feet

CALTRANS 2015 STANDARD PLANS

- A3A ABBREVIATIONS (SHEET 1 OF 3)
- A3B ABBREVIATIONS (SHEET 2 OF 3)
- A3C ABBREVIATIONS (SHEET 3 OF 3)
- A10A LEGEND-LINES AND SYMBOLS (SHEET 1 OF 5)
- RSP A10B LEGEND-LINES AND SYMBOLS (SHEET 2 OF 5)
- A10C LEGEND-LINES AND SYMBOLS (SHEET 3 OF 5)
- A10D LEGEND-LINES AND SYMBOLS (SHEET 4 OF 5)
- A10E LEGEND-LINES AND SYMBOLS (SHEET 5 OF 5)
- A62E EXCAVATION AND BACKFILL - CAST-IN-PLACE REINFORCED CONCRETE BOX AND ARCH CULVERTS
- D81 CAST-IN-PLACE REINFORCED CONCRETE - DOUBLE BOX CULVERT
- D82 CAST-IN-PLACE REINFORCED CONCRETE - DOUBLE BOX CULVERT - MISCELLANEOUS DETAILS
- D88 CONSTRUCTION LOADS ON CULVERTS
- RSP B0-3 BRIDGE DETAILS
- B3-5 RETAINING WALL DETAILS NO. 1

CALTRANS 2018 STANDARD PLANS

- RSP B11-79 CONCRETE BARRIER TYPE 836 (SHEET 1 OF 2)
- RSP B11-80 CONCRETE BARRIER TYPE 836 (SHEET 2 OF 2)

INDEX TO PLANS

SHEET NO.	TITLE
S1	STRUCTURAL GENERAL NOTES
S2	REEDLEY MAIN CANAL GENERAL LAYOUT
S3	REEDLEY MAIN CANAL FOUNDATION PLAN
S4	REEDLEY MAIN CANAL BOX CULVERT DETAILS
S5	TRAVERS CREEK AT LINCOLN AVE GENERAL LAYOUT
S6	TRAVERS CREEK AT LINCOLN AVE FOUNDATION PLAN
S7	CIP BOTTOMLESS CULVERT DETAILS
S8	BOTTOMLESS CULVERT GENERAL CONFIGURATIONS
S9	CIP BOTTOMLESS CULVERT WALL, SLAB, & PILE DETAILS
S10	CIP BOTTOMLESS CULVERT FOUNDATION DETAILS
S11	CIP BOTTOMLESS CULVERT FOOTINGS ON SOIL
S12	TRAVERS CREEK AT PARLIER AVE GENERAL LAYOUT
S13	TRAVERS CREEK AT PARLIER AVE FOUNDATION PLAN
S14	TRAVERS CREEK AT PARLIER AVE BOX CULVERT DETAILS

DESIGNED_MAW	DATE 11/10/17
DRAWN_TZE	11/10/17
CHECKED_JPJ	11/10/17

Scale	AS SHOWN
-------	----------

CORNERSTONE
 structural engineering group

986 W Alluvial Ave - Suite 201
 Fresno, California 93711
 559.320.3200
 fax 559.320.3201



PROJECT	LOCATION VARIES COUNTY OF FRESNO, CA
Road No. -	Bridge No. -

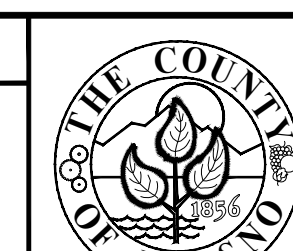

DEPARTMENT OF PUBLIC WORKS & PLANNING	
STRUCTURAL GENERAL NOTES	
Drawing No. S-1	Sheet No. 2 of 40

ABBREVIATIONS

AB	AGGREGATE BASE
AC	ASPHALT CONCRETE
AP	ANGLE POINT
BC	BEGIN CURVE
BEG	BEGIN
C	CUT SLOPE
DWY	DRIVEWAY
(E)	EXISTING
EC	END CURVE
ELEV	ELEVATION
EP	EDGE OF PAVEMENT
ETW	EDGE OF TRAVEL WAY
EXIST	EXISTING
F	FILL SLOPE
HMA	HOT MIX ASPHALT
HP	HINGE POINT
Lt	LEFT
MIN	MINIMUM
OG	ORIGINAL GROUND
OH	OVER HEAD
PG&E	PACIFIC GAS AND ELECTRIC
PRC	POINT OF REVERSING CURVE
PT	POINT
R/W	RIGHT OF WAY
RT	RIGHT
SAW	SAWCUT
SHLD	SHOULDER
STD	STANDARD PLAN
VAR	VARIES
VC	VERTICAL CURVE
VPD	VEHICLES PER DAY
WSE	WATER SURFACE ELEVATION

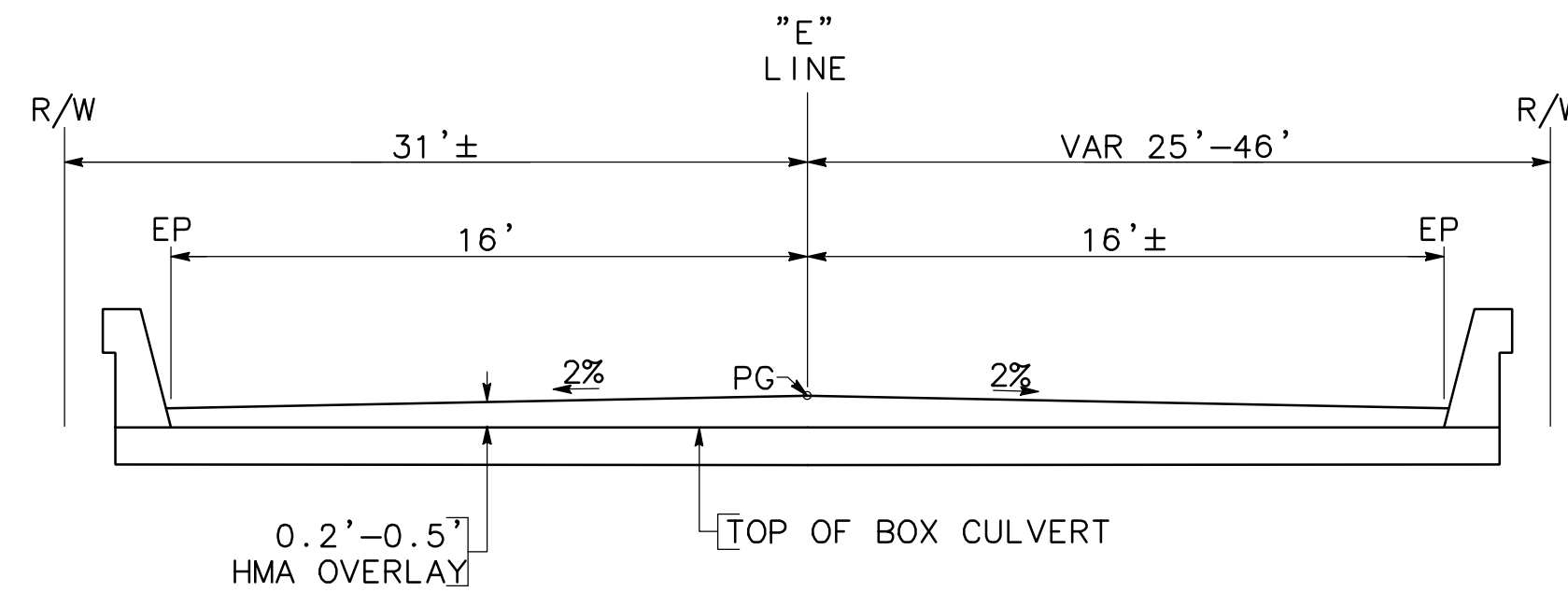

ENGLEHART AVENUE
16+82.66 TO 17+18.71

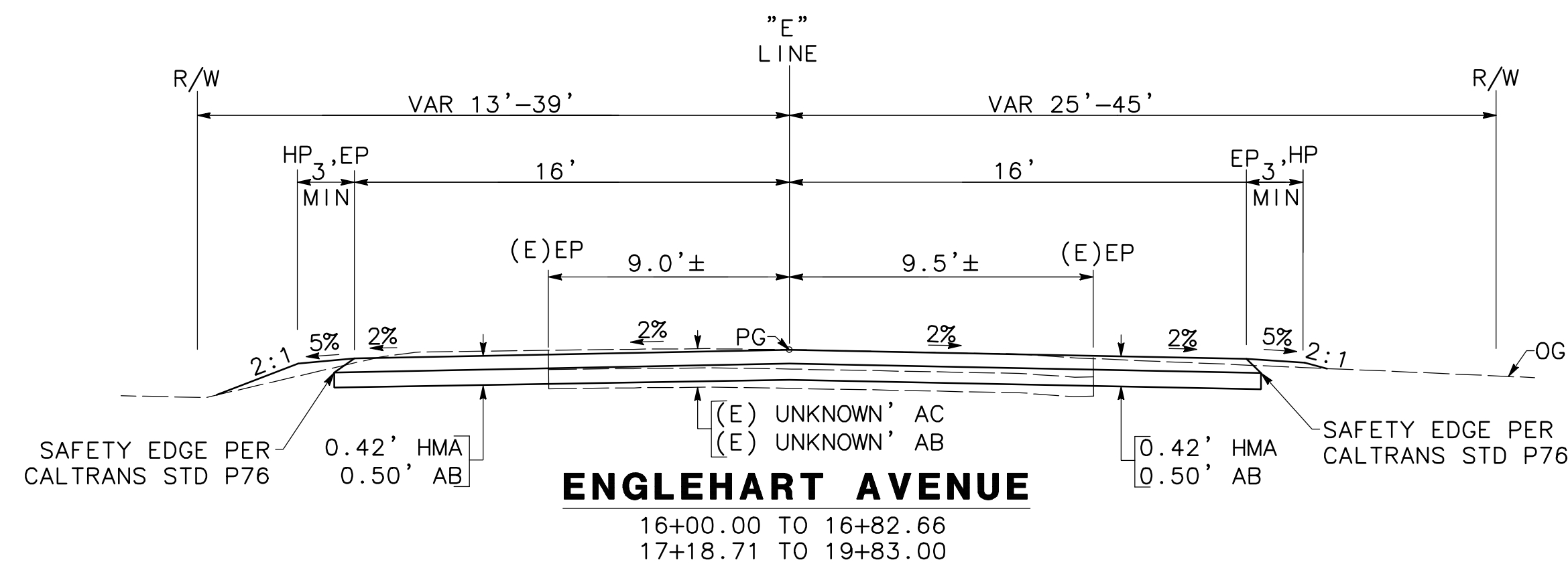

ENGLEHART AVENUE
16+00.00 TO 16+82.66
17+18.71 TO 19+83.00

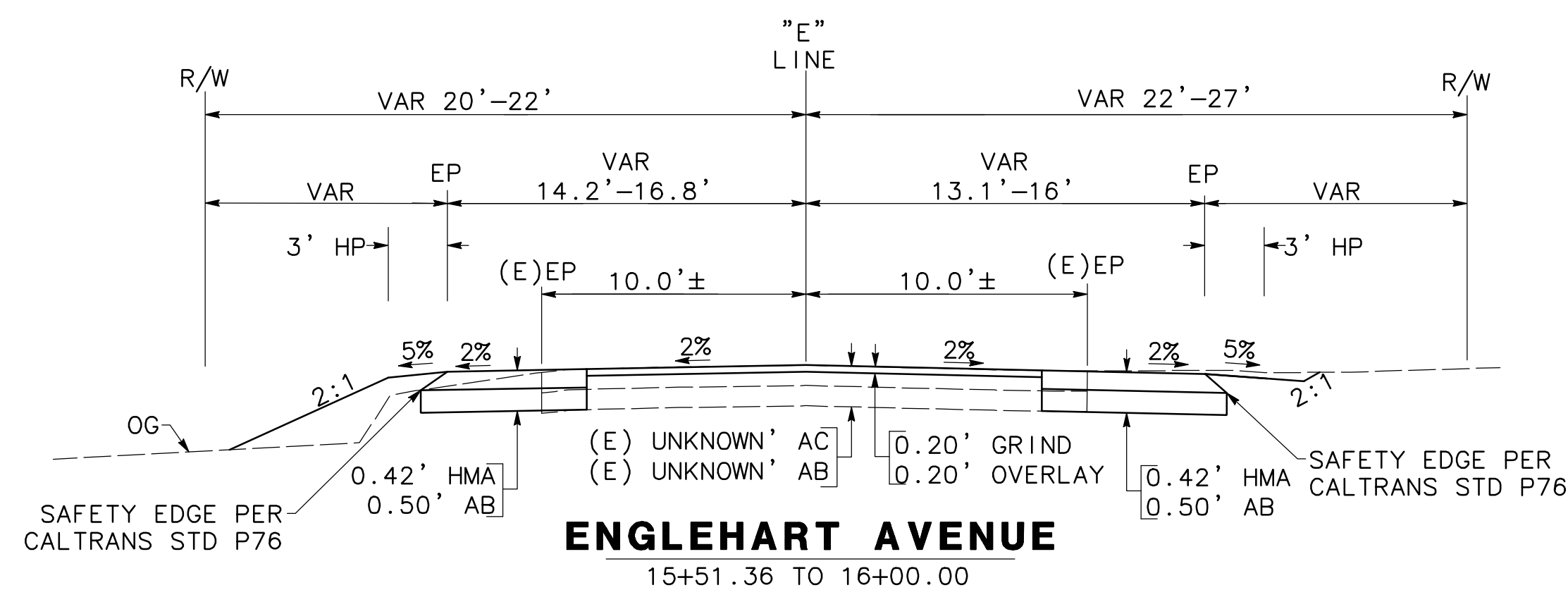

ENGLEHART AVENUE
15+51.36 TO 16+00.00

DESIGNED: CL		DATE: 04/14/2023	RECORD DRAWING		SCALE	PROJECT		DEPARTMENT OF PUBLIC WORKS AND PLANNING	
DRAWN: DA		DATE: 04/14/2023	RESIDENT ENGINEER			REEDLEY MAIN AT ENGLEHART AVE		REEDLEY MAIN CANAL	
CHECKED: CH		DATE: 04/14/2023				COUNTY OF FRESNO, CA		TYPICAL SECTIONS	
FOR RIGHT OF WAY DATA AND ACCURATE ACCESS DETERMINATION, SEE DOCUMENTS IN THE DEPARTMENT OF PUBLIC WORKS AND PLANNING.					SUPERVISING ENGINEER		ROAD NO. 2809	BRIDGE NO. 42C0708	DRAWING NO. X-1
					DATE		SHEET NO. 3		TOTAL 40

GENERAL NOTES

1. CONTRACTORS SHALL COMPLY WITH BUSINESS AND PROFESSIONS CODE SECTION 8771(B) REGARDING REFERENCING, PRESERVING, AND RECONSTRUCTING MONUMENTS, WHETHER OR NOT MONUMENTS ARE SHOWN IN THESE PLANS.
2. CONTRACTOR SHALL PROVIDE THE ENGINEER A MINIMUM OF (2) WEEKS NOTICE PRIOR TO COMMENCING ANY WORK THAT COULD DAMAGE OR DESTROY ANY SURVEY MONUMENTS.
3. IF MONUMENT IS DAMAGED BY CONSTRUCTION OPERATIONS THE CONTRACTOR SHALL REPLACE AT THE CONTRACTORS COST.

BASIS OF COORDINATES:

THE WEST LINE OF THE SOUTH WEST QUARTER OF SECTION 31-T14S, R24E BEARS N1°27'30"W PER MAP FILED IN BOOK 20, OF RECORD OF SURVEYS AT PAGE 38, FRESNO COUNTY RECORDS.

BASIS OF VERTICAL CONTROL:

FRESNO COUNTY BENCHMARK LN 1, A FRESNO COUNTY BRASS CAP MONUMENT ON THE SOUTHEAST END OF A CONCRETE WEIR STRUCTURE AT THE NORTHWEST CORNER OF AMERICAN AVENUE AND ENGLEHART AVENUE, HAS AN NGVD29 ELEVATION OF 398.028 FEET, PER FRESNO COUNTY BENCHMARK RECORDS.

LEGEND

- FRESNO COUNTY CONTROL POINTS

CONTROL FOR DESIGN & CONSTRUCTION

POINT	NORTHING	EASTING	ELEVATION	DESCRIPTION
101	10000.01	10000.01	397.63	FRESNO COUNTY BRASS CAP MONUMENT FLUSH
102	9993.42	7354.05	386.62	1" IRON PIPE DOWN 20"
103	12642.48	9932.73	401.62	1" IRON PIPE W/ FRESNO COUNTY TAG DOWN 7"
104	10001.81	12628.61	395.75	FRESNO COUNTY BRASS CAP MONUMENT FLUSH
105	7358.09	9986.38	387.03	1 1/4" IRON PIPE DOWN 13"



	DATE	RECORD DRAWING	SCALE		PROJECT	<i>DEPARTMENT OF PUBLIC WORKS AND PLANNING</i>
DESIGNED: CL	04/14/2023	RESIDENT ENGINEER		_____ SUPERVISING ENGINEER	REEDLEY MAIN AT ENGLEHART AVE	 REEDLEY MAIN CANAL PROJECT CONTROLS
DRAWN: DA	04/14/2023			_____ DATE	COUNTY OF FRESNO, CA	
CHECKED: CH	04/14/2023				ROAD NO. 2809 BRIDGE NO. 42C0708	
FOR RIGHT OF WAY DATA AND ACCURATE ACCESS DETERMINATION, SEE DOCUMENTS IN THE DEPARTMENT OF PUBLIC WORKS AND PLANNING.						
				DRAWING NO. PC-1		SHEET NO. 4 TOTAL 40

GENERAL NOTES

- FOR CONTROL LINE & MONUMENT INFORMATION, SEE PC-1.
- FOR SIGN AND STRIPING INFORMATION SEE, SS-1.
- FOR BRIDGE INFORMATION SEE STRUCTURE SHEETS.
- FOR GRADING INFORMATION SEE CD-1
- CONCRETE SLOPE PAVING BEHIND WING WALL 2' WIDE TO TOP OF CHANNEL AND 6" MAX DEEP AS DIRECTED BY THE COUNTY ENGINEER.

LEGEND:

- NEW PAVEMENT
- REMOVE TREE
- AC PAVEMENT
- AB PAVEMENT
- HMA OVERLAY
- SAWCUT
- CUT SLOPE
- FILL SLOPE
- GRIND OVERLAY

CURVE DATA

No. (X)	R	Δ	T	L
1	3200.00'	1°45'29"	49.09'	98.18'
2	1900.00'	3°45'30"	62.34'	124.63'
3	1900.00'	3°50'52"	63.82'	127.59'
4	3184.00'	1°14'37"	34.56'	69.11'
5	1884.00'	3°29'31"	57.43'	114.82'
6	2339.62'	2°15'34"	46.14'	92.27'
7	3216.00'	1°29'16"	41.75'	83.50'
8	1916.00'	3°48'42"	63.76'	127.47'
9	1611.00'	1°41'59"	23.90'	47.79'

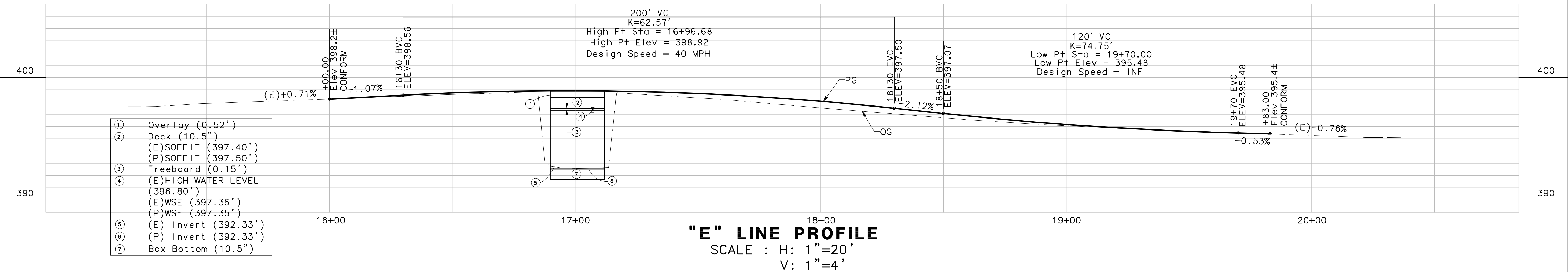
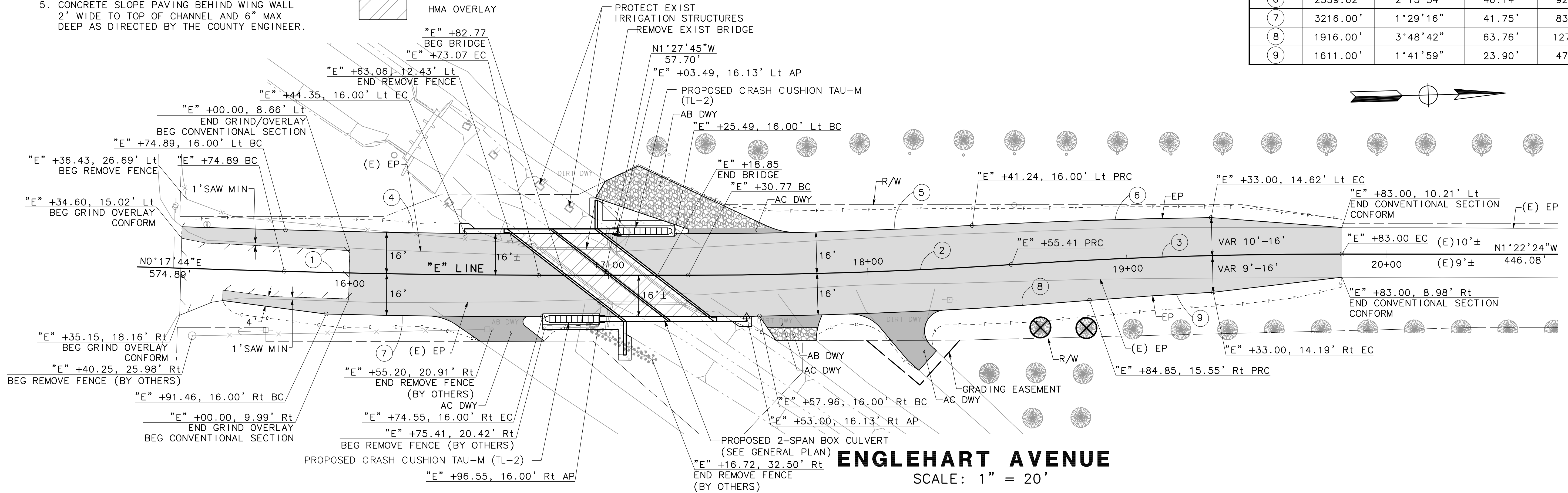

DESIGNED: CL	DATE: 04/14/2023	RECORD DRAWING	SCALE	PROJECT	DEPARTMENT OF PUBLIC WORKS AND PLANNING
DRAWN: DA	04/14/2023	RESIDENT ENGINEER	0 10 20 40	REEDLEY MAIN AT ENGLEHART AVE	REEDLEY MAIN CANAL
CHECKED: CH	04/14/2023		SCALE: 1" = 20'	COUNTY OF FRESNO, CA	PLAN AND PROFILE
FOR RIGHT OF WAY DATA AND ACCURATE ACCESS DETERMINATION, SEE DOCUMENTS IN THE DEPARTMENT OF PUBLIC WORKS AND PLANNING.				ROAD NO. 2809	TOTAL 40

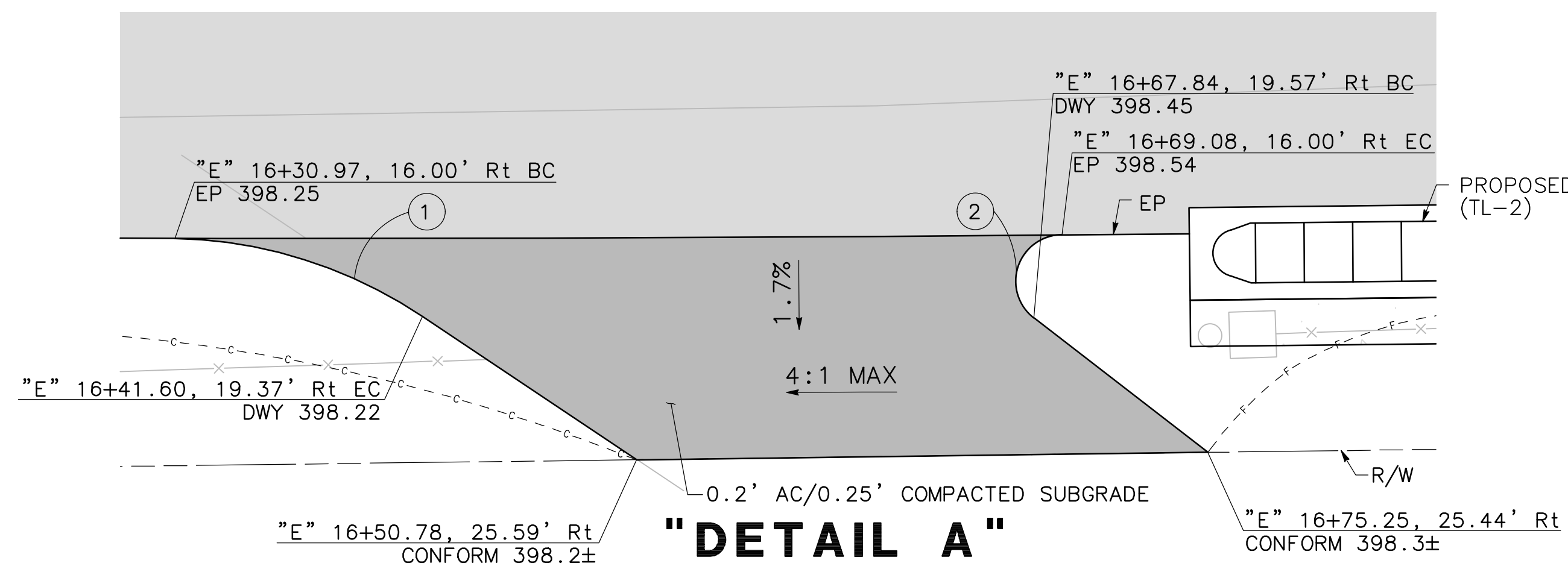

"DETAIL A"
SCALE: 1" = 5'

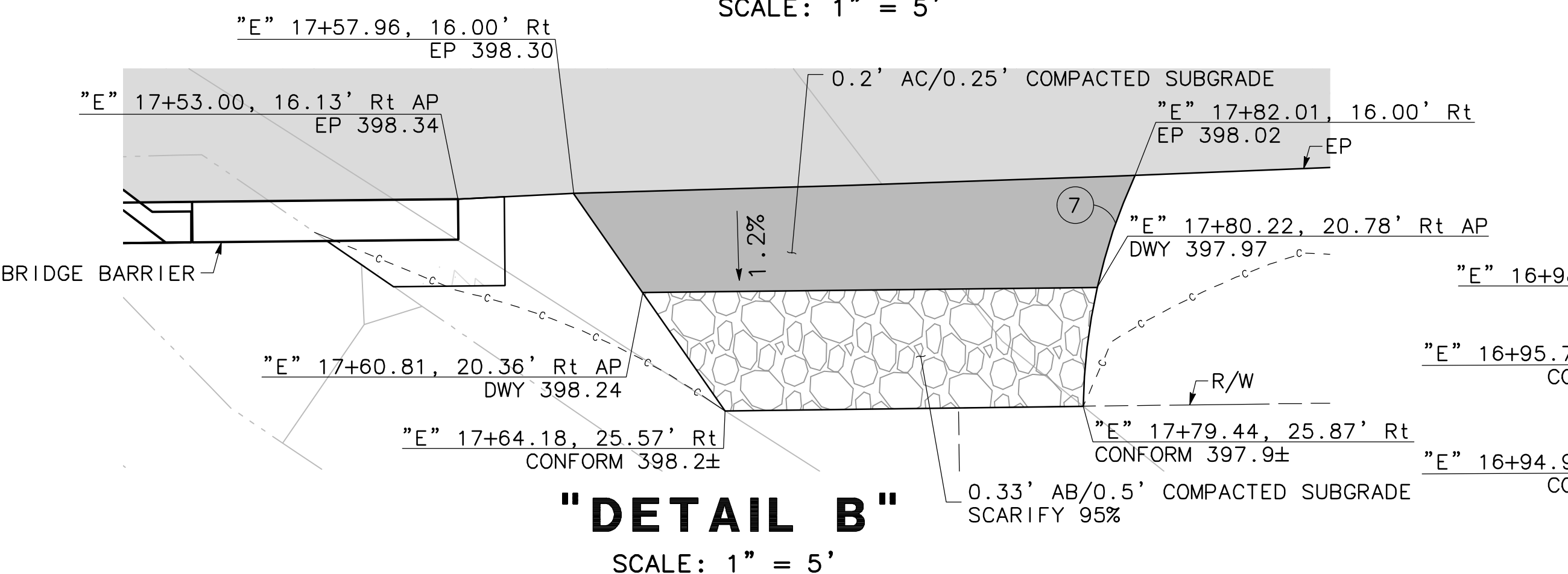

"DETAIL B"
SCALE: 1" = 5'

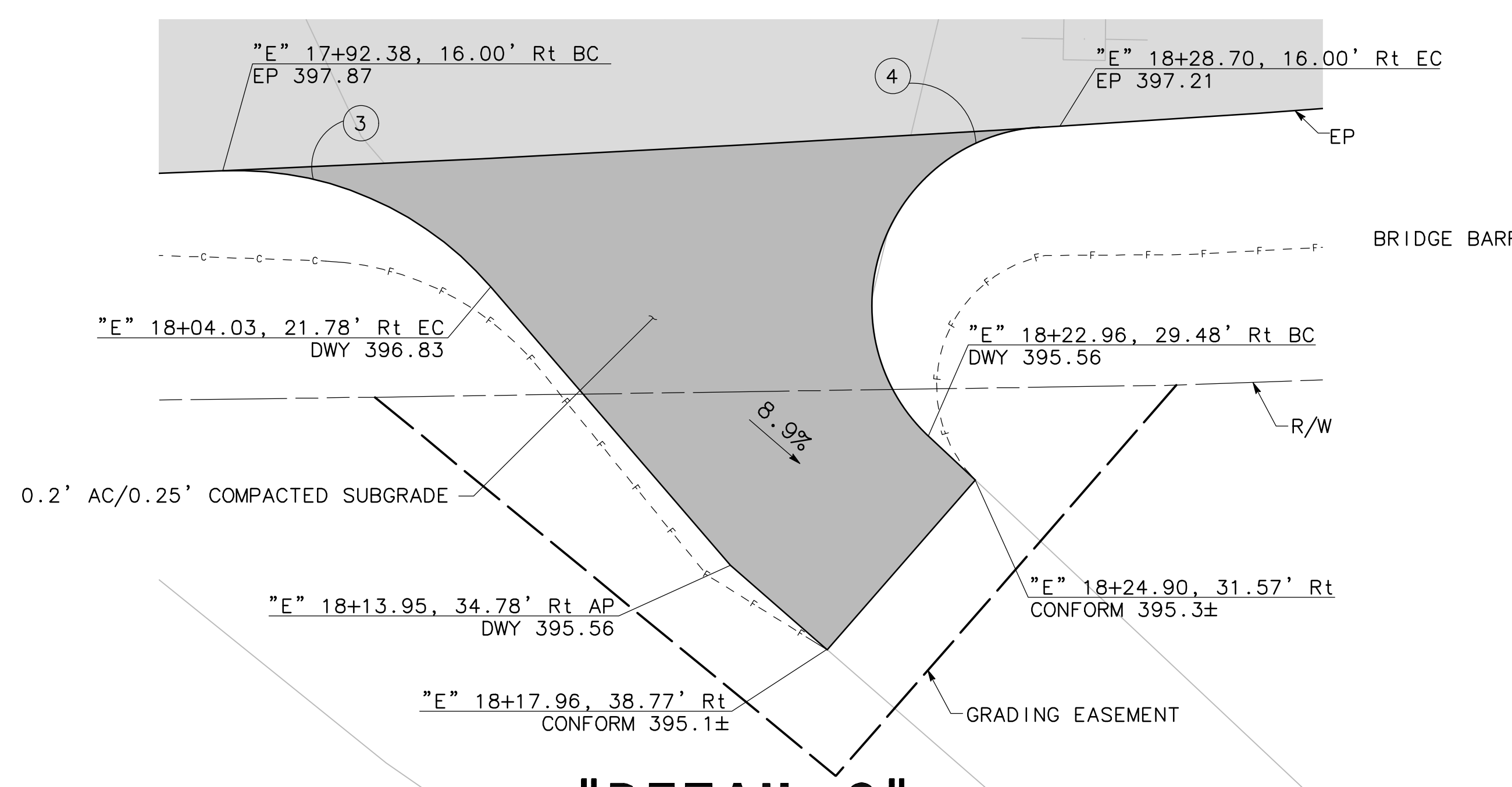

"DETAIL C"
SCALE: 1" = 5'

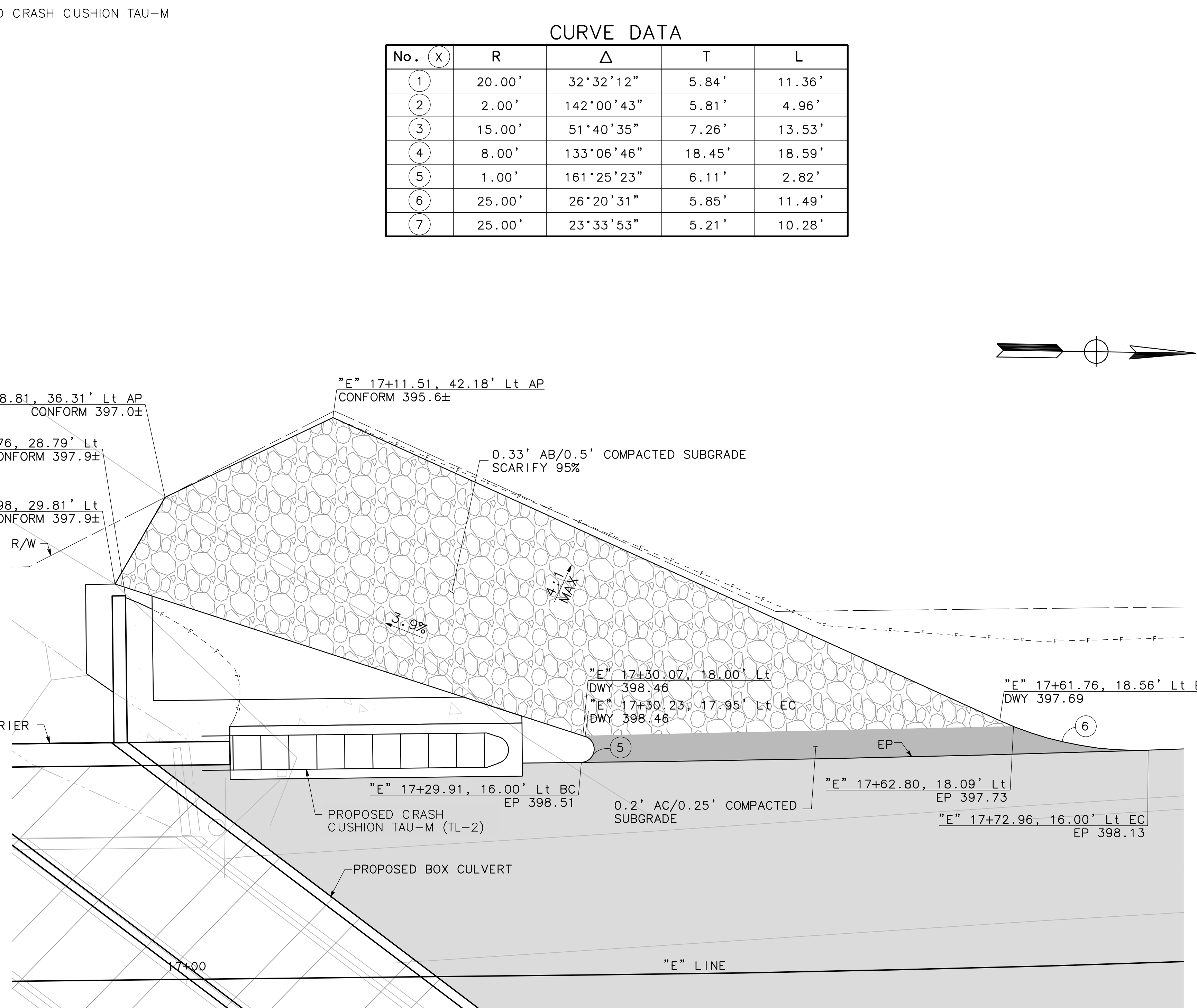

"DETAIL D"
SCALE: 1" = 5'

CURVE DATA

No. (X)	R	Δ	T	L
①	20.00'	32°32'12"	5.84'	11.36'
②	2.00'	142°00'43"	5.81'	4.96'
③	15.00'	51°40'35"	7.26'	13.53'
④	8.00'	133°06'46"	18.45'	18.59'
⑤	1.00'	161°25'23"	6.11'	2.82'
⑥	25.00'	26°20'31"	5.85'	11.49'
⑦	25.00'	23°33'53"	5.21'	10.28'

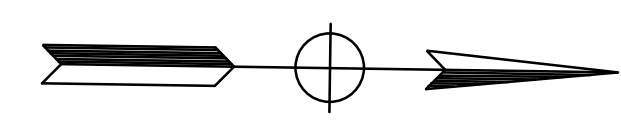

DESIGNED: CL	DATE: 04/14/2023	RECORD DRAWING	SCALE		PROJECT		DEPARTMENT OF PUBLIC WORKS AND PLANNING
DRAWN: DA	04/14/2023	RESIDENT ENGINEER	0 2.5 5 10		REEDLEY MAIN AT ENGLEHART AVE		REEDLEY MAIN CANAL CONSTRUCTION DETAILS
CHECKED: CH	04/14/2023		SCALE: 1" = 5'		COUNTY OF FRESNO, CA		
FOR RIGHT OF WAY DATA AND ACCURATE ACCESS DETERMINATION, SEE DOCUMENTS IN THE DEPARTMENT OF PUBLIC WORKS AND PLANNING.				SUPERVISING ENGINEER	DATE	ROAD NO. 2809	BRIDGE NO. 42C0708
						DRAWING NO. CD-1	SHEET NO. 6
						TOTAL 40	

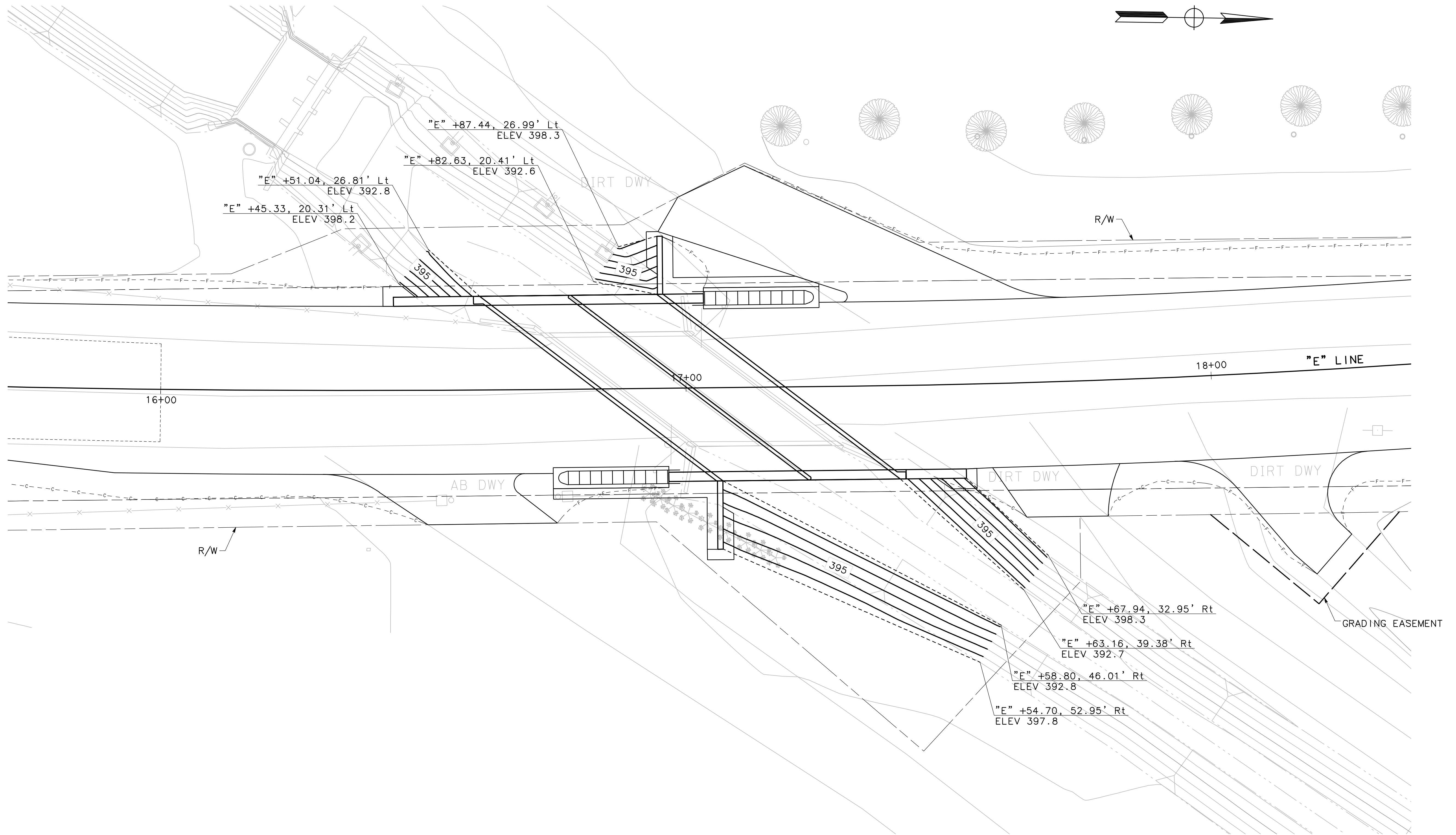

"DETAIL E"
SCALE: 1" = 10'

DESIGNED: CL		DATE: 04/14/2023	RECORD DRAWING		SCALE		PROJECT		DEPARTMENT OF PUBLIC WORKS AND PLANNING	
DRAWN: DA		DATE: 04/14/2023	RESIDENT ENGINEER		0 5 10 20		REEDLEY MAIN AT ENGLEHART AVE		REEDLEY MAIN CANAL	
CHECKED: CH		DATE: 04/14/2023			SCALE: 1" = 10'		COUNTY OF FRESNO, CA		CONSTRUCTION DETAILS	
							ROAD NO. 2809		DRAWING NO. CD-2	
							BRIDGE NO. 42C0708		SHEET NO. 7	
									TOTAL 40	

FOR RIGHT OF WAY DATA AND ACCURATE ACCESS DETERMINATION, SEE DOCUMENTS IN THE DEPARTMENT OF PUBLIC WORKS AND PLANNING.

GENERAL NOTES

LOCATIONS FOR EXISTING UNDERGROUND FACILITIES ARE APPROXIMATE. EXACT DEPTH AND LOCATIONS ARE UNKNOWN. FIELD LOCATE PRIOR TO THE START OF CONSTRUCTION.

**CALL UNDERGROUND SERVICE ALERT (USA) 811

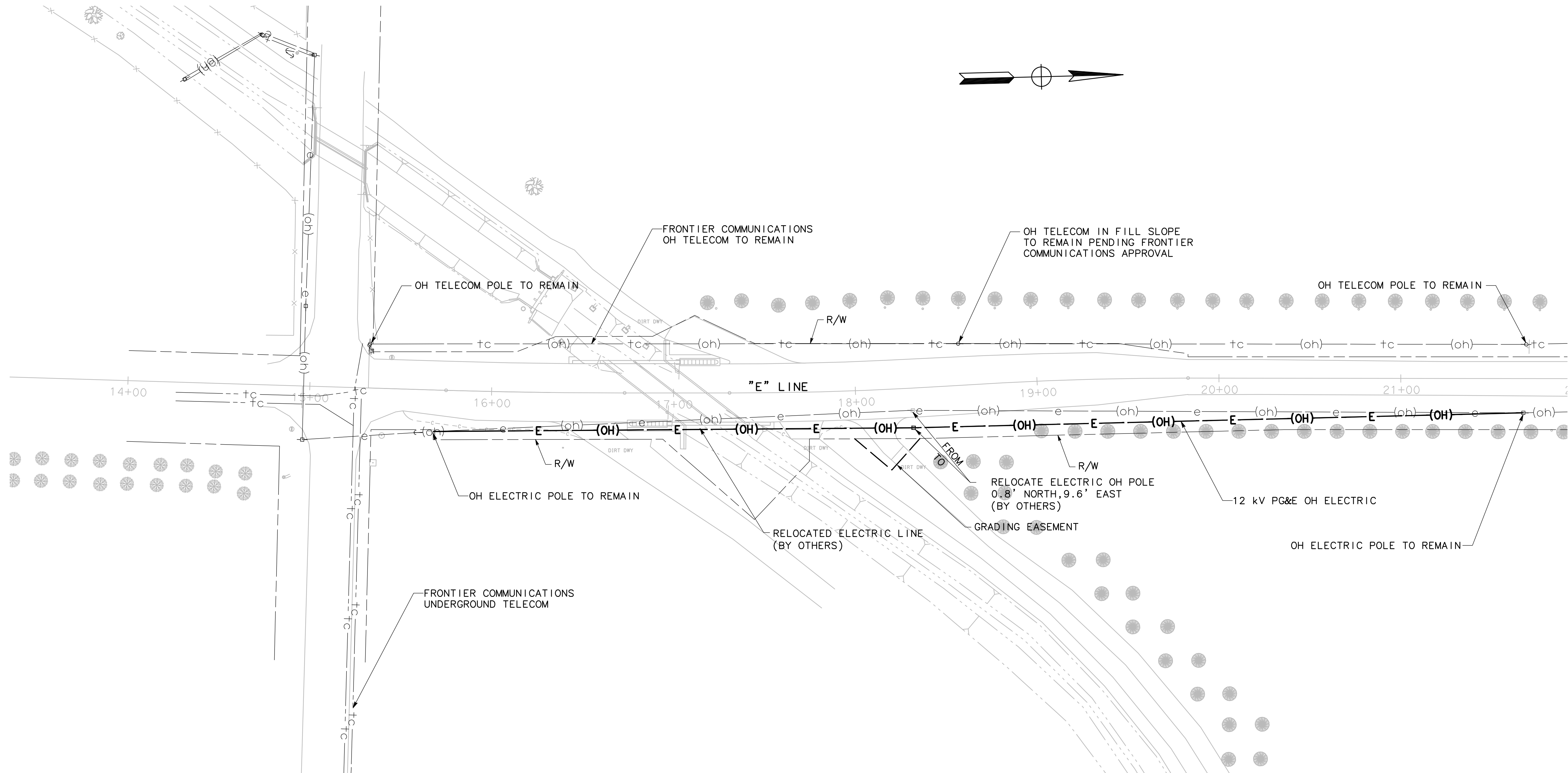

ENGLEHART AVENUE

SCALE: 1" = 30'







DESIGNED: CL		DATE: 04/14/2023	RECORD DRAWING		SCALE		PROJECT		DEPARTMENT OF PUBLIC WORKS AND PLANNING	
DRAWN: DA		DATE: 04/14/2023	RESIDENT ENGINEER		0 15 30 60		REEDLEY MAIN AT ENGLEHART AVE		REEDLEY MAIN CANAL	
CHECKED: CH		DATE: 04/14/2023			SCALE: 1" = 30'		COUNTY OF FRESNO, CA		UTILITY PLAN	
							ROAD NO. 2809		DRAWING NO. U-1	
							BRIDGE NO. 42C0708		SHEET NO. 8	
									TOTAL 40	

FOR RIGHT OF WAY DATA AND ACCURATE ACCESS DETERMINATION, SEE DOCUMENTS IN THE DEPARTMENT OF PUBLIC WORKS AND PLANNING.

GENERAL NOTES

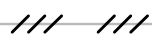
1. WORK SHALL BE DONE IN ACCORDANCE WITH THE 2015 STANDARD PLANS AND SPECIFICATIONS OF THE STATE OF CALIFORNIA DEPARTMENT OF TRANSPORTATION, SIGN SPECIFICATION SHEETS, THE LATEST EDITION OF THE 2014 CALIFORNIA MANUAL ON UNIFORM TRAFFIC CONTROL DEVICES (CA MUTCD), AND THE SPECIAL PROVISIONS.
2. THESE SIGNING AND STRIPING PLANS ARE ACCURATE FOR SIGNING AND PAVEMENT MARKINGS ONLY. ALL REFERENCE TO PAVEMENT MARKINGS SHALL INCLUDE STRIPING.
3. ALL SALVAGED MATERIAL SHALL BE DELIVERED TO THE COUNTY SIGN SHOP (BUILDING 409) AT 4551 E. HAMILTON AVENUE. THE CONTRACTOR SHALL NOTIFY THE SIGN SHOP (559)600-7899 AT LEAST TWO WORKING DAYS PRIOR TO DELIVERY.
4. ALL EXISTING PAVEMENT MARKING WHICH CONFLICTS WITH PROPOSED PAVEMENT MARKING SHALL BE REMOVED.
5. EXISTING PAVEMENT MARKINGS TO BE REMOVED SHALL BE DONE BY GRINDING. AFTER GRINDING, A PARKING AREA SEAL SHALL BE APPLIED TO THE AREA.
6. ALL PAVEMENT MARKINGS SHALL BE THERMOPLASTIC.
7. ALL EXISTING SIGNS NOT SHOWN ON THE PLANS TO REMAIN OR BE RELOCATED SHALL REMAIN, BE SALVAGED, OR RELOCATED AS DIRECTED BY THE ENGINEER.
8. SIGNS SHALL BE TYPE iv OR ix RETROREFLECTIVE SHEETING IN ACCORDANCE WITH ASTM 4956-09. ALL SIGNS SHALL BE COVERED WITH A TRANSLUCENT ANTI-GRAFFITI FLUOROPOLYMER FILM THAT DOES NOT IMPAIR THE REFLECTIVITY OF THE SIGN.

LEGEND:

-  INSTALL TRAFFIC SIGN. TEXT INDICATES CA MUTCD SIGN CODE
-  # DENOTES DETAIL NUMBER PER CALTRANS STANDARD PLAN
-  DENOTES EXIST DETAIL NUMBER PER CALTRANS STANDARD PLAN
-  REMOVE YELLOW TRAFFIC STRIPE (HAZARDOUS WASTE)
-  * INSTALL ROADSIDE SIGN
-  ● EXISTING SIGN TO BE REMOVED
-  ■ EXISTING SIGN TO BE RELOCATED
-  LL 24" WIDE WHITE LIMIT LINE

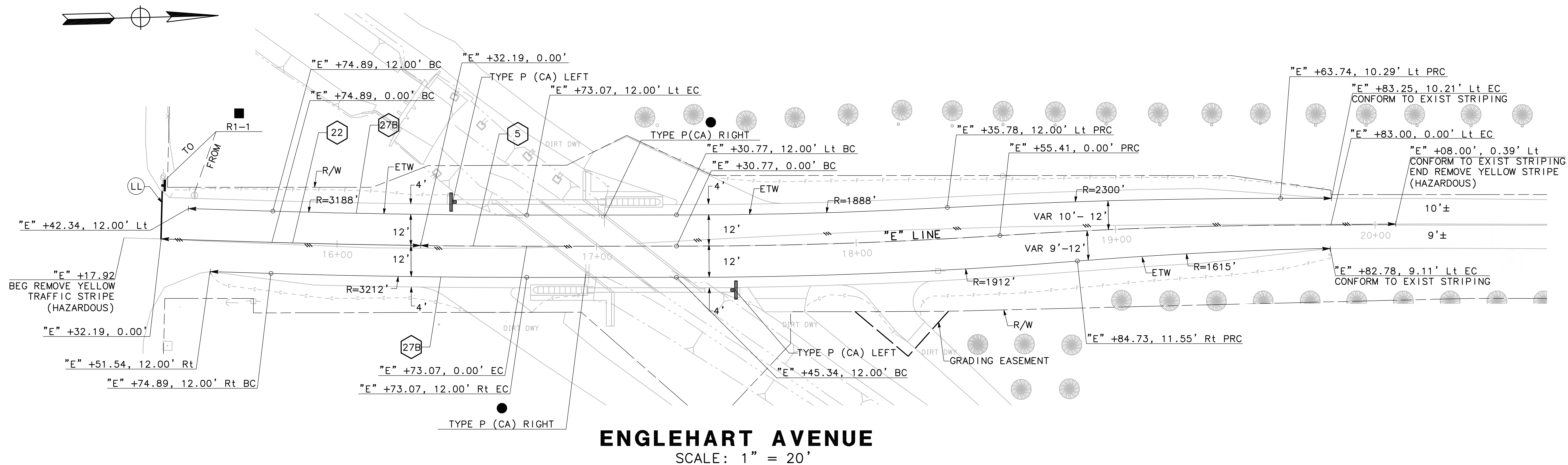

ENGLEHART AVENUE
SCALE: 1" = 20'

DESIGNED: CL	DATE: 04/14/2023	RECORD DRAWING	SCALE	PROJECT			DEPARTMENT OF PUBLIC WORKS AND PLANNING
DRAWN: DA	DATE: 04/14/2023	RESIDENT ENGINEER	0 10 20 40	REEDLEY MAIN AT ENGLEHART AVE			REEDLEY MAIN CANAL
CHECKED: CH	DATE: 04/14/2023		SCALE: 1" = 20'	COUNTY OF FRESNO, CA			SIGNING AND STRIPING PLAN
FOR RIGHT OF WAY DATA AND ACCURATE ACCESS DETERMINATION, SEE DOCUMENTS IN THE DEPARTMENT OF PUBLIC WORKS AND PLANNING.				ROAD NO. 2809	BRIDGE NO. 42C0708		DRAWING NO. SS-1
				SUPERVISING ENGINEER	DATE		SHEET NO. 9
							TOTAL 40

STATIONARY MOUNTED CONSTRUCTION AREA SIGNS

SIGN LETTER	SIGN CODE	PANEL SIZE	SIGN MESSAGE	EACH (N)
(A)	M4-8A	24" x 18"	END DETOUR	2
(B)	M4-9(L)	30" x 24"	DETOUR WITH ARROW (LEFT)	3
(C)	M4-9(R)	30" x 24"	DETOUR WITH ARROW (RIGHT)	3
(D)	M4-10(L)	48" x 18"	DETOUR ARROW (LEFT)	1
(E)	R3-1	24" x 24"	NO RIGHT TURN SYMBOL	2
(F)	R11-2	48" x 30"	ROAD CLOSED	2
(G)	R11-4	60" x 30"	ROAD CLOSED TO THRU TRAFFIC	1
(H)	SC3(CA)	36" x 12"	DETOUR WITH ARROW (STRAIGHT)	5
(I)	W20-1	36" x 36"	ROAD WORK AHEAD	1
(J)	W20-3	36" x 36"	ROAD CLOSED AHEAD	1
(K)	R3-2	24" x 24"	NO LEFT TURN SYMBOL	1
(L)	CUSTOM	54" x 36"	SB ENGLEHART AVE CLOSED FOLLOW DETOUR	2
(M)	CUSTOM	54" x 36"	NB ENGLEHART AVE CLOSED FOLLOW DETOUR	3
TOTAL				27

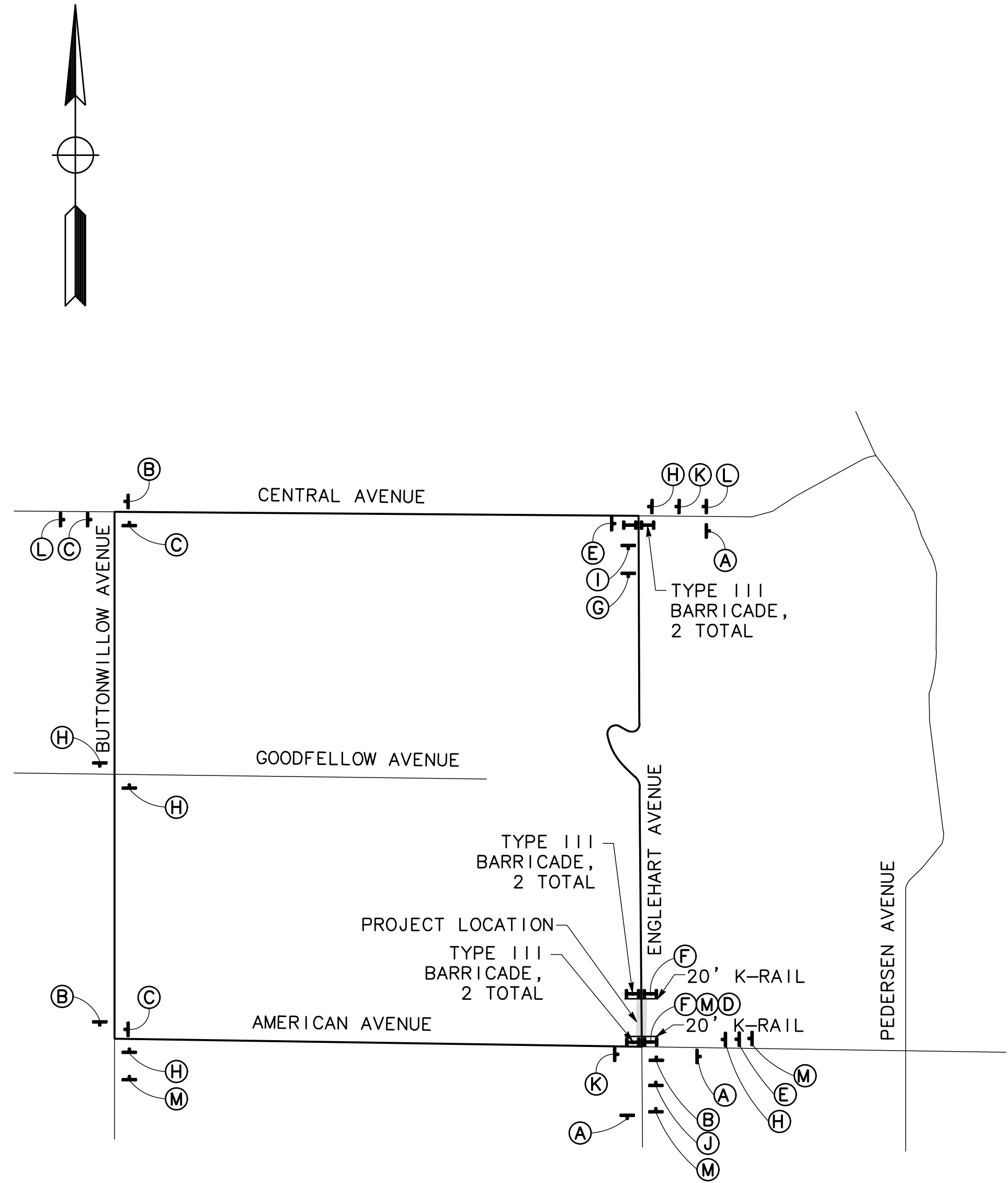

GENERAL NOTES

1. LOCATION OF CONSTRUCTION AREA/DETOUR SIGNS SHOWN ARE APPROXIMATE. EXACT SIGN LOCATION IS TO BE DETERMINED BY THE ENGINEER.
2. ALL TRAFFIC CONTROL DEVICES, BARRIERS, SIGNS, PAVEMENT MARKINGS, AND CHANNELIZATION DEVICES SHALL CONFORM TO THE MOST RECENT VERSION OF THE CA MUTCD.
3. FOR SIGN SPACING, REFER TO 2014 CA MUTCD (REV 2) TABLE 6H-3. REFER 2014 CA MUTCD FOR MEANING OF LETTER CODES ON TYPICAL APPLICATION DIAGRAMS.
4. CONTRACTOR TO PROVIDE REASONABLE MEANS FOR PROPERTY OWNERS ADJACENT CONSTRUCTION TO ACCESS PROPERTIES AT ALL TIMES.
5. CONTRACTOR TO COORDINATE ANY DRIVEWAY CLOSURES WITH PROPERTY OWNERS BEFORE REMOVING ACCESS.

	DATE	RECORD DRAWING	SCALE				
DESIGNED: CL	04/14/2023	RESIDENT ENGINEER	 SCALE: 1" = 1000'	_____ SUPERVISING ENGINEER	_____ DATE	PROJECT REEDLEY MAIN AT ENGLEHART AVE COUNTY OF FRESNO, CA	DEPARTMENT OF PUBLIC WORKS AND PLANNING REEDLEY MAIN CANAL TRAFFIC DETOUR PLAN
DRAWN: DA	04/14/2023			ROAD NO. 2809 BRIDGE NO. 42C0708	DRAWING NO. TD-1 SHEET NO. 10 TOTAL 40		
CHECKED: CH	04/14/2023						

FOR RIGHT OF WAY DATA AND ACCURATE ACCESS DETERMINATION, SEE DOCUMENTS IN THE DEPARTMENT OF PUBLIC WORKS AND PLANNING.

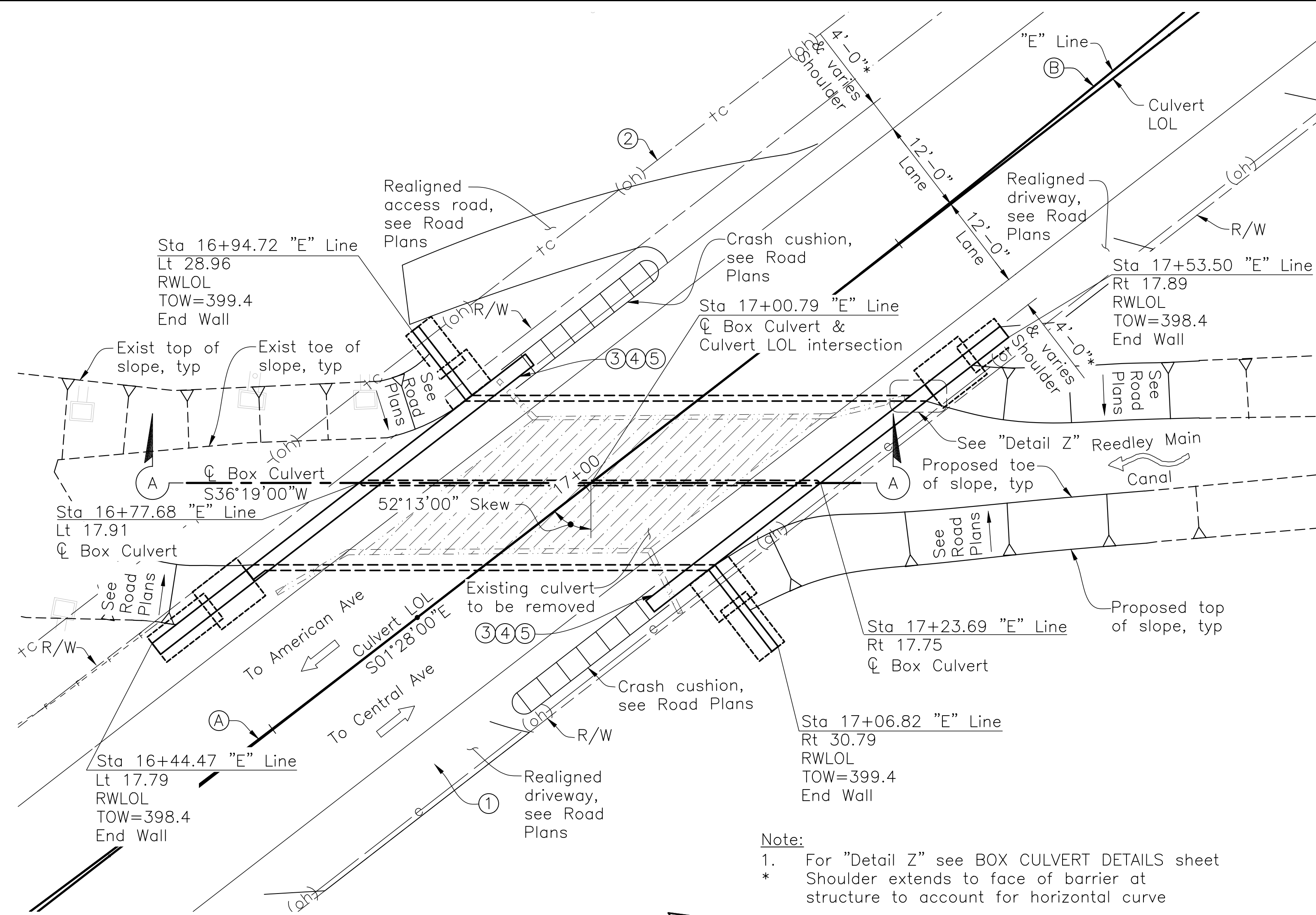

- Legend:**
- BOF Indicates bottom of footing elevation
 - TOW Indicates top of wall elevation
 - RWLOL Indicates retaining wall layout line
 - R/W Indicates right of way
 - ① Existing overhead electrical
 - ② Existing overhead telephone
 - ③ Paint "Reedley Main Canal"
 - ④ Paint "State Br. No. 42C0708"
 - ⑤ Paint "County Br. No. 10-044"
 - Indicates existing private irrigation valve, protect in place
 - Indicates existing structure to be removed
 - Indicates lean concrete or crushed gravel backfill
 - Indicates asphalt concrete overlay
 - Indicates direction of traffic
 - Indicates Caltrans Standard Plan sheet no.
 - Indicates detail no.

Note:
 1. For "Detail Z" see BOX CULVERT DETAILS sheet
 * Shoulder extends to face of barrier at structure to account for horizontal curve

PLAN
 1"=10'-0"

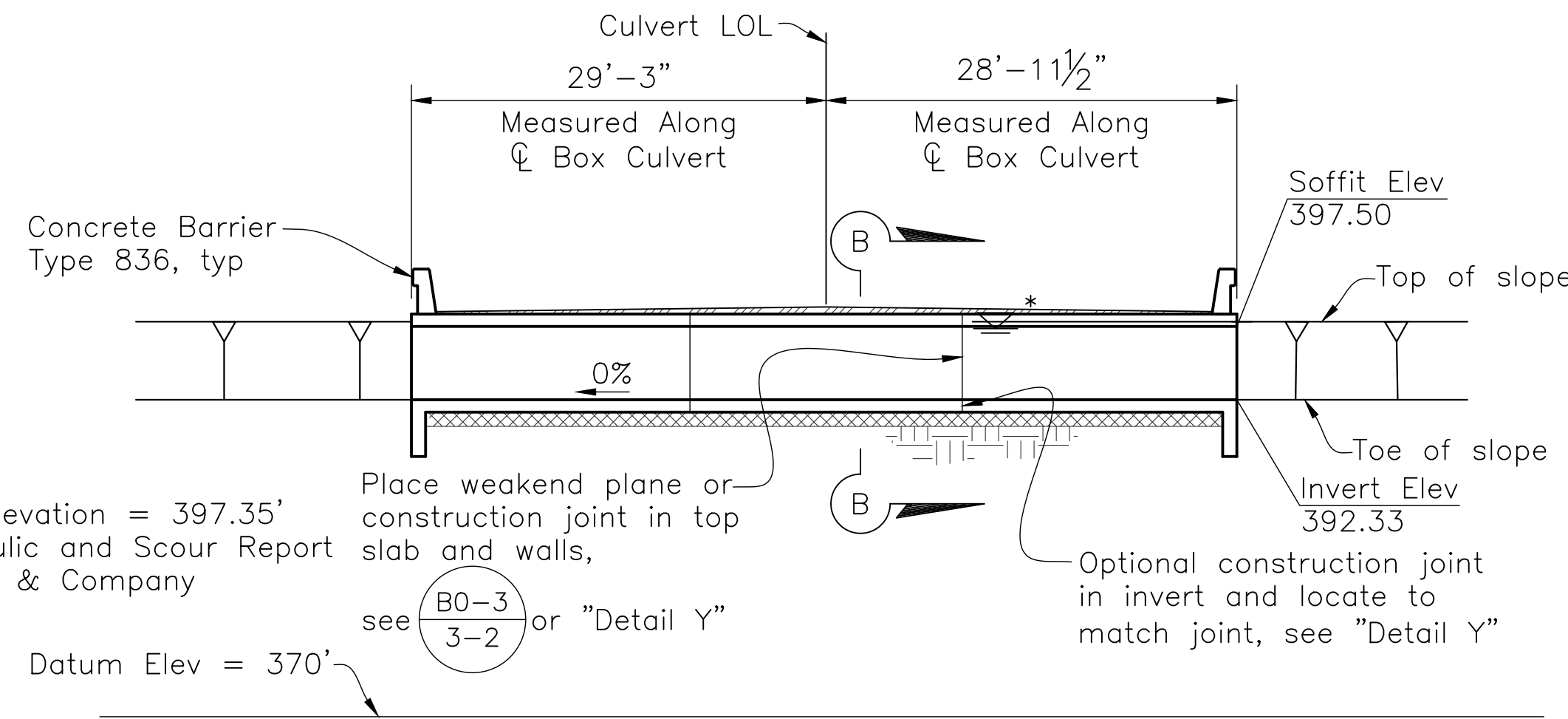

* Water Surface Elevation = 397.35'
 Based on Hydraulic and Scour Report by Mark Thomas & Company

- Notes:**
- For "Section B-B" see BOX CULVERT DETAILS sheet
 - For "Detail Y" see BOX CULVERT DETAILS sheet

CURVE DATA				
CURVE	R	Δ	T	L
(A)	3200.00'	1°45'29"	49.09'	98.18'
(B)	1900.00'	3°45'30"	62.34'	124.63'

DESIGNED_MAW DRAWN_TZE CHECKED_JPJ	DATE 11/10/17 11/10/17 11/10/17	Scale AS SHOWN	CORNERSTONE structural engineering group 986 W Alluvial Ave - Suite 201 Fresno, California 93711 559.320.3200 fax 559.320.3201	PROJECT REEDLEY MAIN AT ENGLEHART AVE COUNTY OF FRESNO, CA Road No. 2809 Bridge No. 42C0708	DEPARTMENT OF PUBLIC WORKS & PLANNING REEDLEY MAIN CANAL GENERAL LAYOUT Drawing No. S-2 Sheet No. 11 of 40
--	--	-------------------	--	--	---

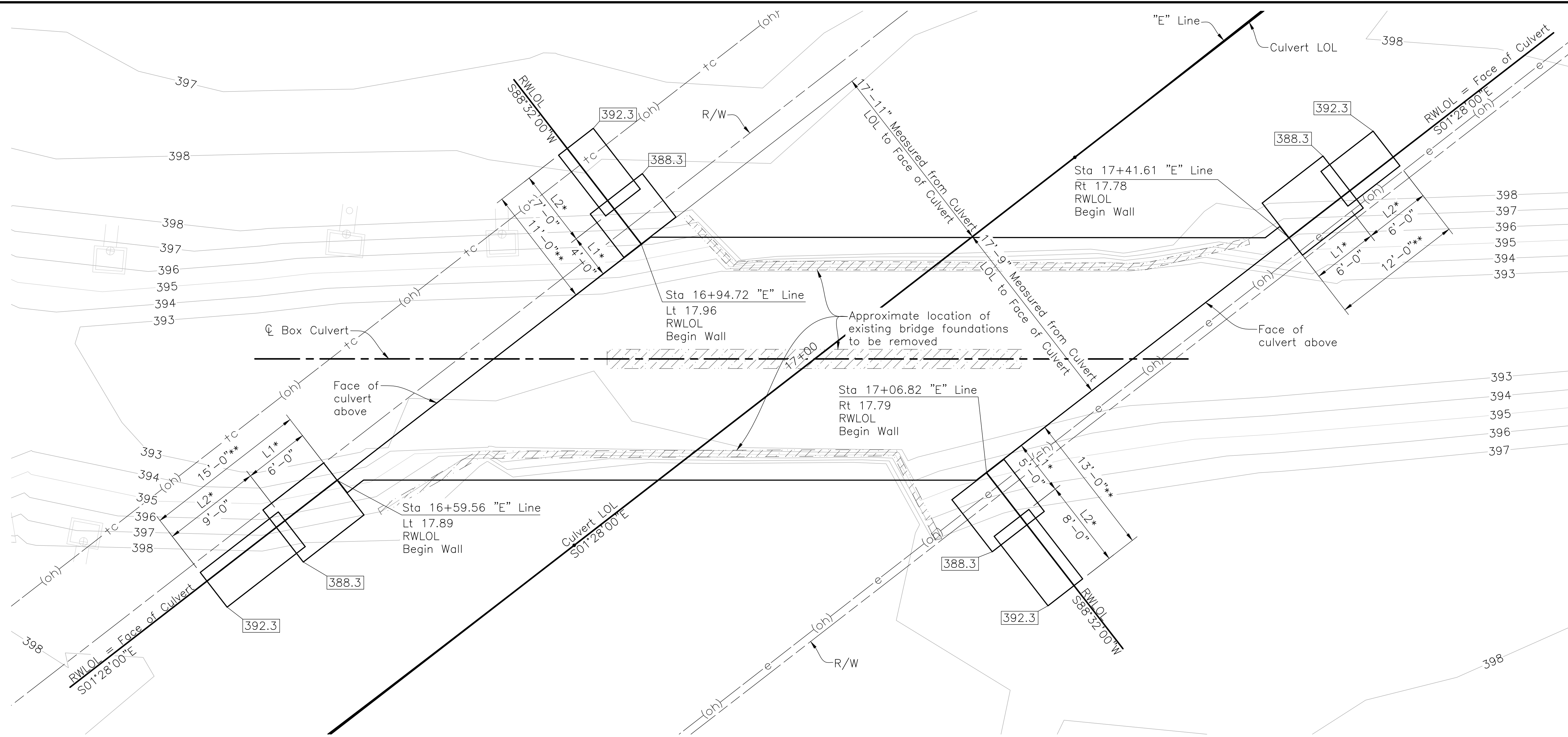

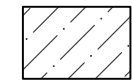
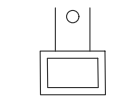

Notes:

1. 388.3 Indicates bottom of footing elevation.
2. -380- Indicates contour elevation.
3.  Indicates existing structure to be removed.
4.  Indicates existing private irrigation valve, protect in place
5. Contractor shall verify all existing controlling field dimensions before ordering or fabricating any material.
6. Contours shown indicate existing conditions. For finished grade limits, see Road Plans.
7. * See "North Elevation" on BOX CULVERT DETAILS sheet.
8. ** Indicates length of retaining wall measured along RWLOL.

PLAN
1"=5'-0"

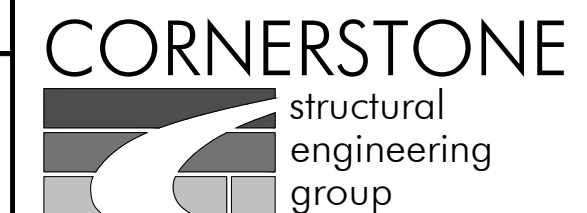
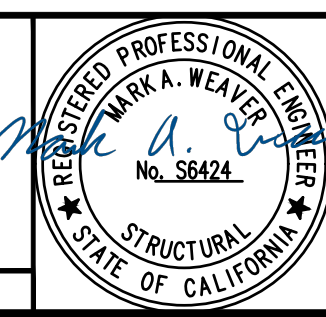

DESIGNED_MAW	DATE 11/10/17	Scale AS SHOWN		986 W Alluvial Ave - Suite 201 Fresno, California 93711 559.320.3200 fax 559.320.3201		PROJECT REEDLEY MAIN AT ENGLEHART AVE COUNTY OF FRESNO, CA Road No. 2809 Bridge No. 42C0708		DEPARTMENT OF PUBLIC WORKS & PLANNING REEDLEY MAIN CANAL FOUNDATION PLAN Drawing No. S-3 Sheet No. 12 of 40
--------------	------------------	-------------------	--	--	---	--	---	---

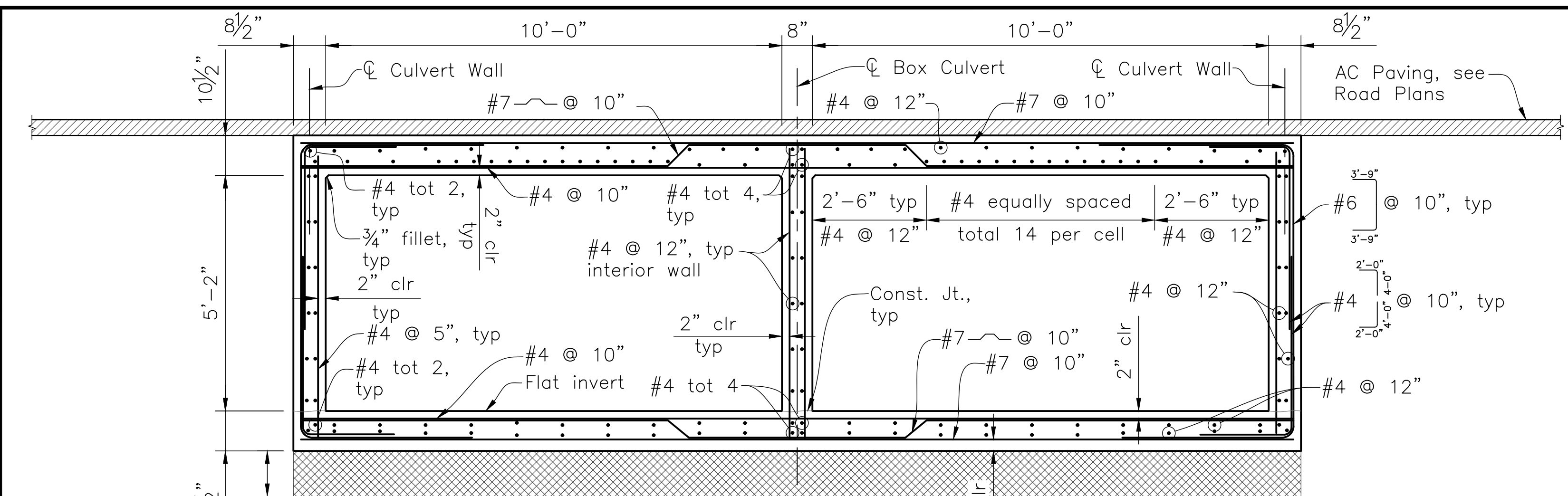

SECTION B-B
1/2" = 1'-0"

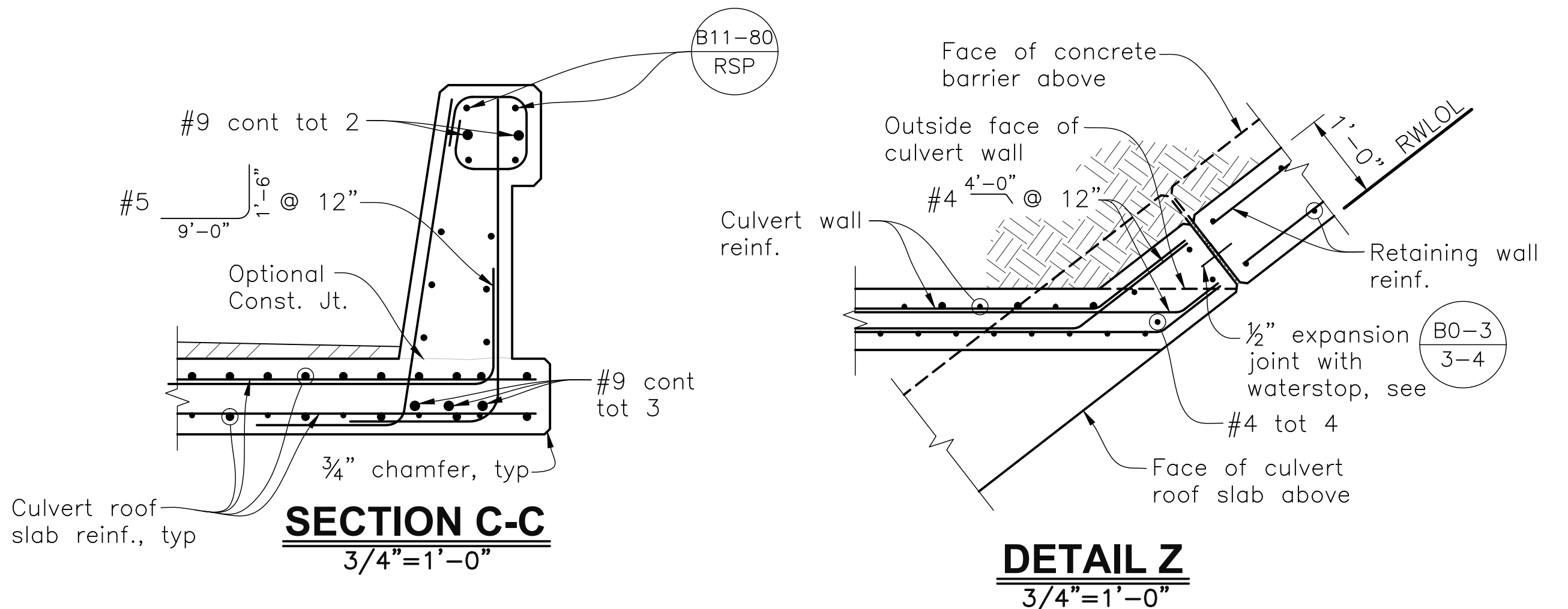

SECTION C-C
3/4" = 1'-0"

DETAIL Z
3/4" = 1'-0"

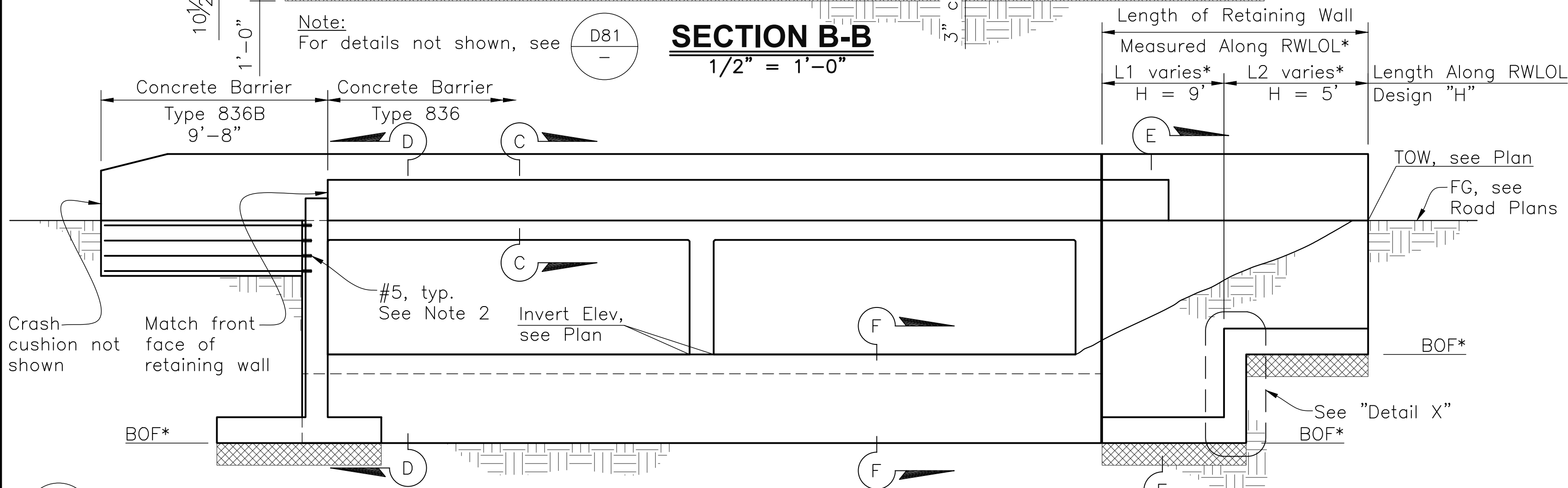

EAST ELEVATION
1/4" = 1'-0"

- Notes:**
1. East elevation shown, west elevation similar.
 2. #5 tot 8 drill and epoxy in 5" deep hole in exterior culvert wall. See "Type 836" detail on B11-80 RSP for more details.

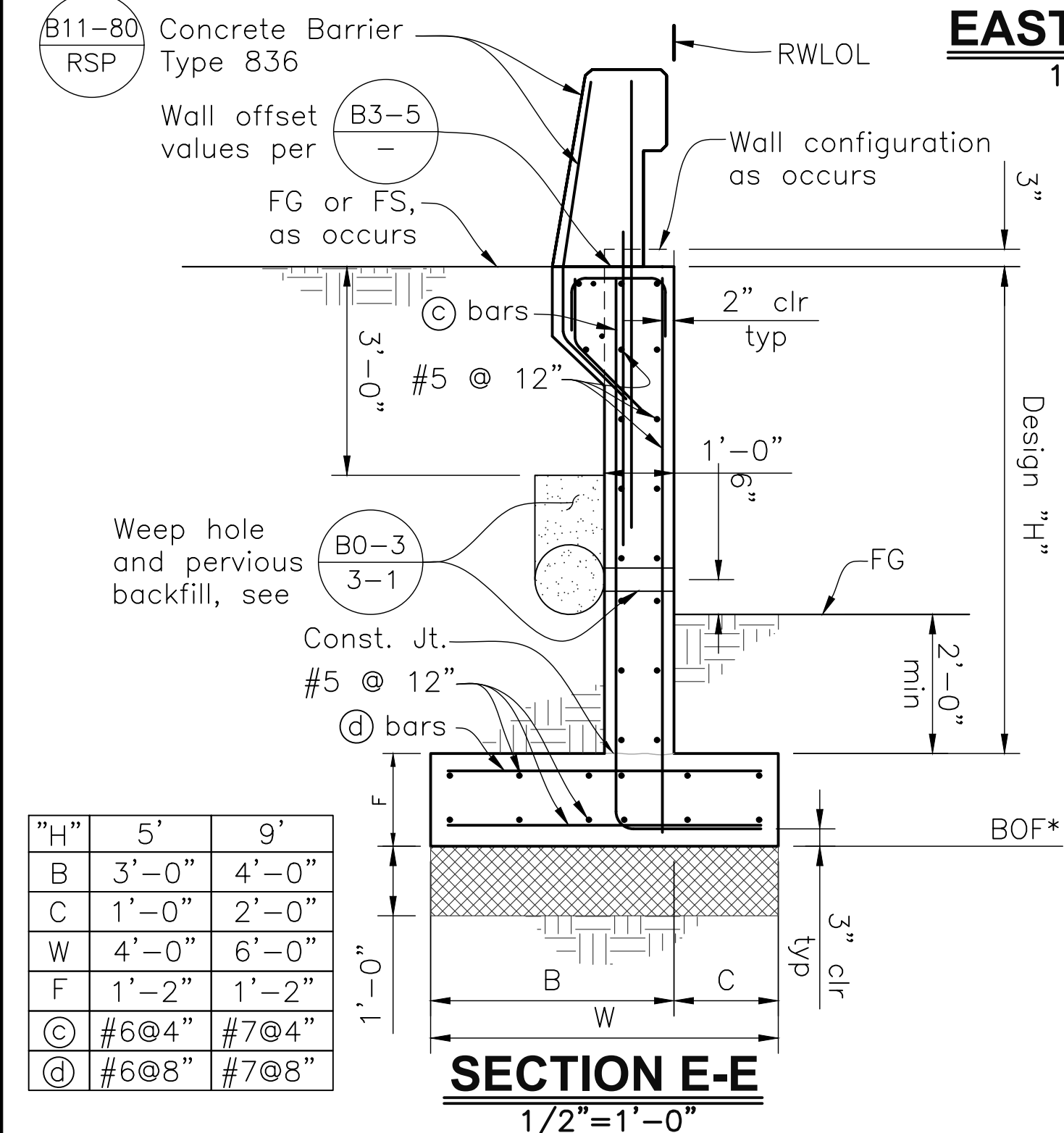

SECTION E-E
1/2" = 1'-0"

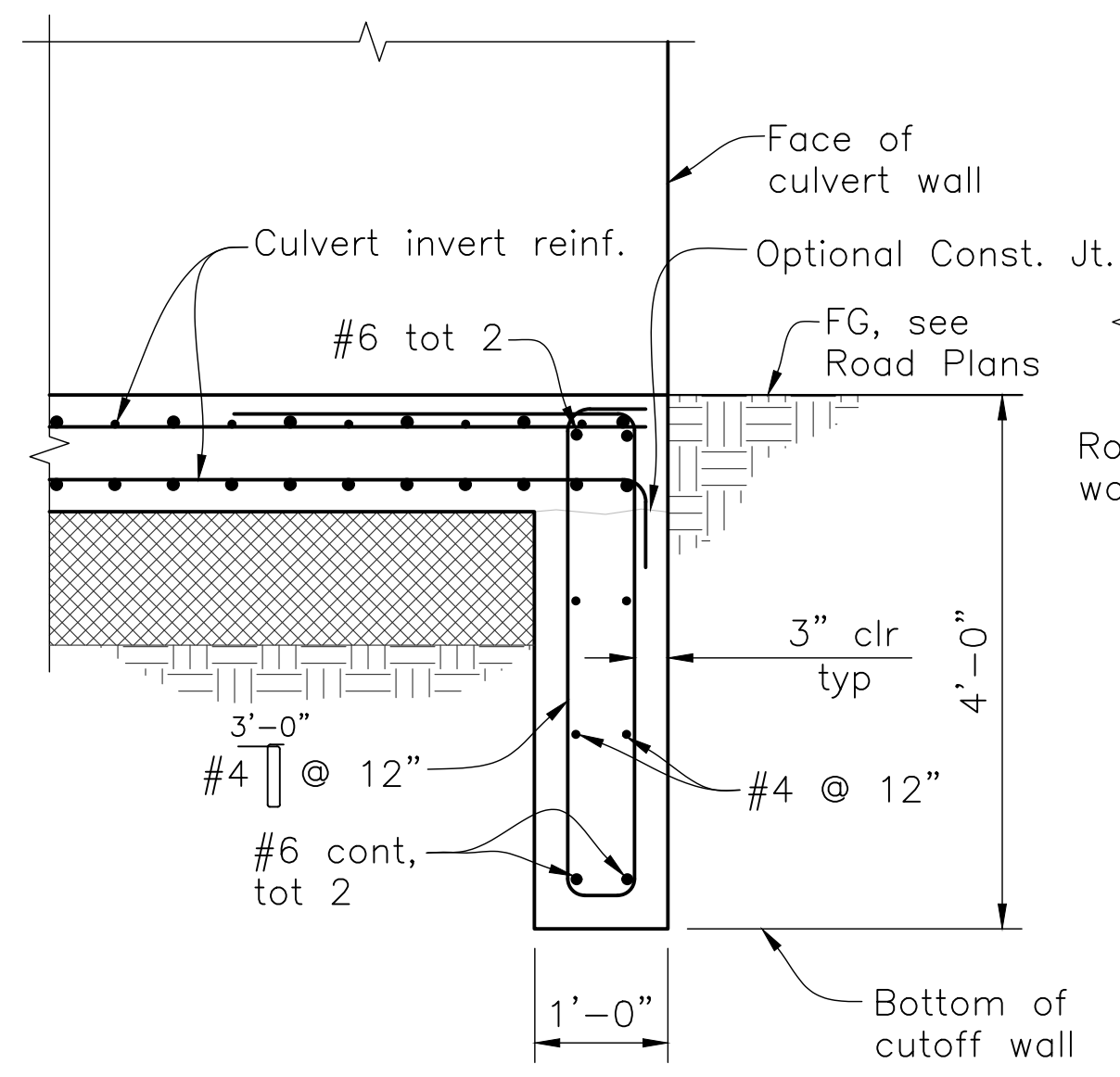

SECTION F-F
3/4" = 1'-0"

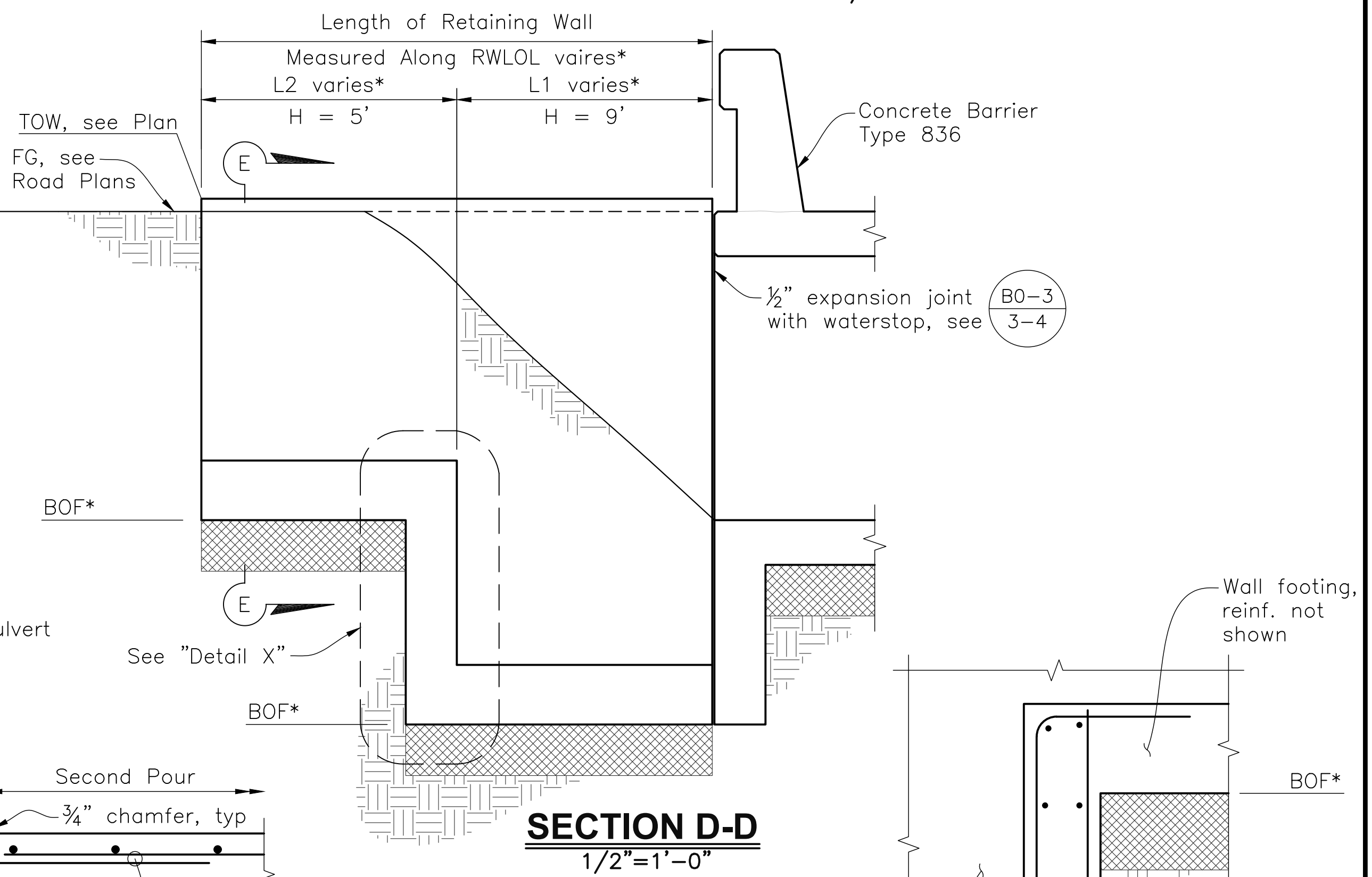

SECTION D-D
1/2" = 1'-0"

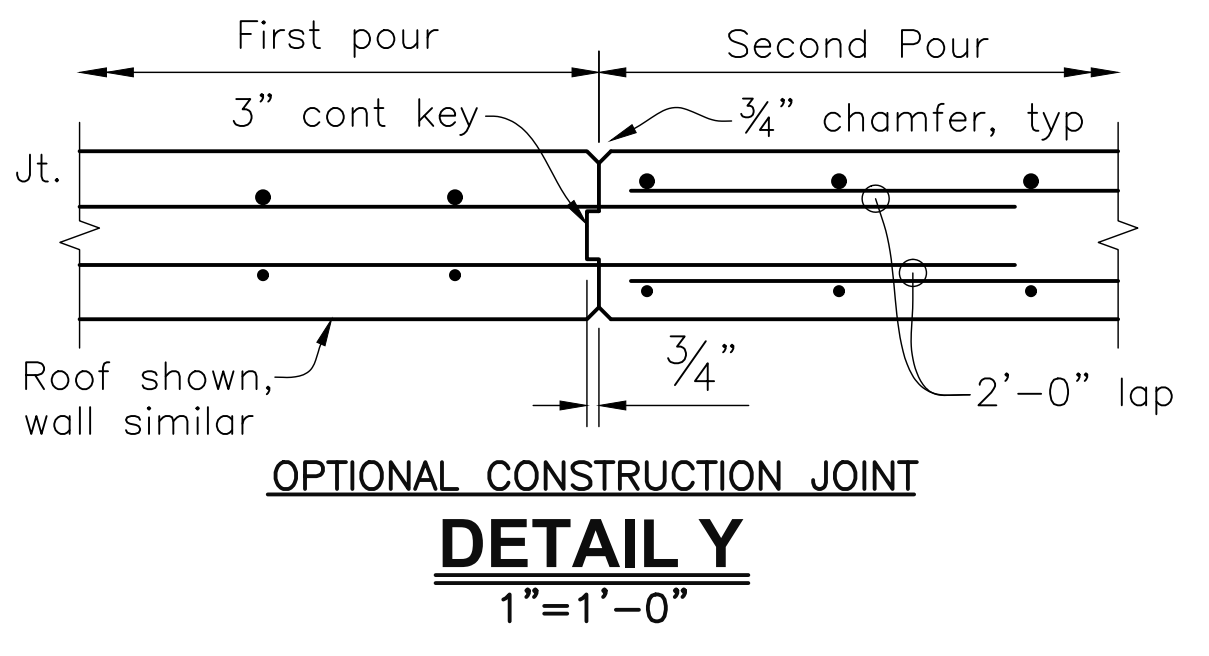

DETAIL Y
1" = 1'-0"

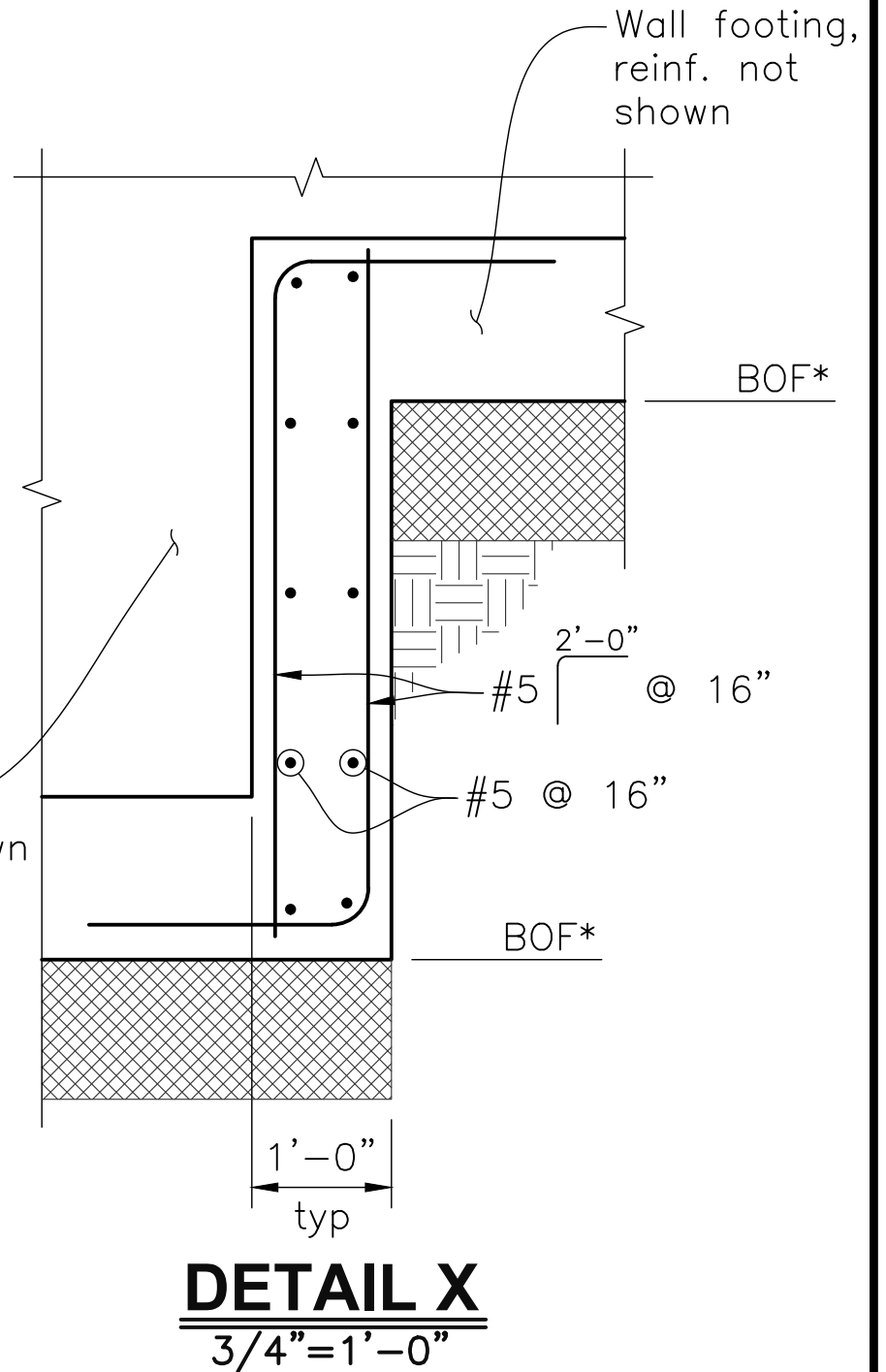

DETAIL X
3/4" = 1'-0"

"H"	5'	9'
B	3'-0"	4'-0"
C	1'-0"	2'-0"
W	4'-0"	6'-0"
F	1'-2"	1'-2"
ⓐ	#6@4"	#7@4"
ⓑ	#6@8"	#7@8"

- General Notes:**
- * See FOUNDATION PLAN sheet
 - BOF Indicates bottom of footing elevation
 - TOW Indicates top of wall elevation
 - RWLOL Indicates retaining wall layout line
 - ▨ Indicates lean concrete or crushed gravel backfill

DESIGNED_MAW	DATE 11/10/17
DRAWN_TZE	11/10/17
CHECKED_JPU	11/10/17
REVISION	

Scale	AS SHOWN
-------	----------

CORNERSTONE
structural engineering group
986 W Alluvial Ave - Suite 201
Fresno, California 93711
559.320.3200
fax 559.320.3201

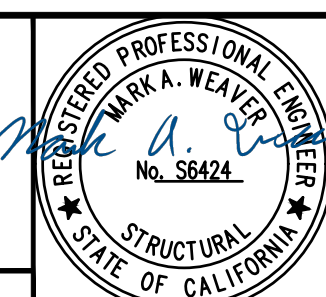

PROJECT
REEDLEY MAIN AT ENGLEHART AVE
COUNTY OF FRESNO, CA
Road No. 2809 Bridge No. 42C0708



DEPARTMENT OF PUBLIC WORKS & PLANNING
REEDLEY MAIN CANAL
BOX CULVERT DETAILS
Drawing No. S-4 Sheet No. 13 of 40

ABBREVIATIONS

AB	AGGREGATE BASE
AC	ASPHALT CONCRETE
AP	ANGLE POINT
BEG	BEGIN
DWY	DRIVEWAY
(E)	EXISTING
ETW	EDGE OF TRAVEL WAY
EP	EDGE OF PAVEMENT
HMA	HOT MIX ASPHALT
HP	HINGE POINT
Lt	LEFT
MIN	MINIMUM
OG	ORIGINAL GROUND
PG	PROFILE GRADE
R/W	RIGHT OF WAY
RAP	RECLAIMED ASPHALT PAVEMENT
RCP	REINFORCED CONCRETE PIPE
RSP	ROCK SLOPE PROTECTION
Rt	RIGHT
SAW	SAWCUT
SHLD	SHOULDER
TCE	TEMPORARY CONSTRUCTION EASEMENT
VAR	VARIES
WSE	WATER SURFACE ELEVATION

GENERAL NOTES

1. RAP NOT TO BE USED FOR BACKFILL NEAR WATERWAY.

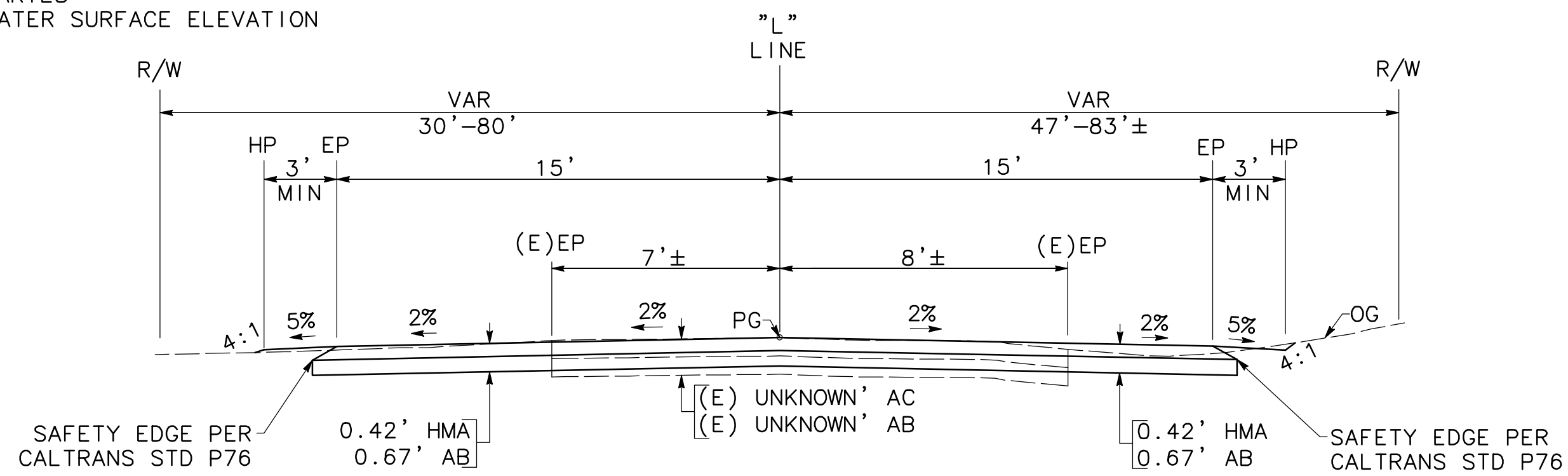

LINCOLN AVENUE

38+75.00 TO 39+17.42
39+41.69 TO 39+85.00

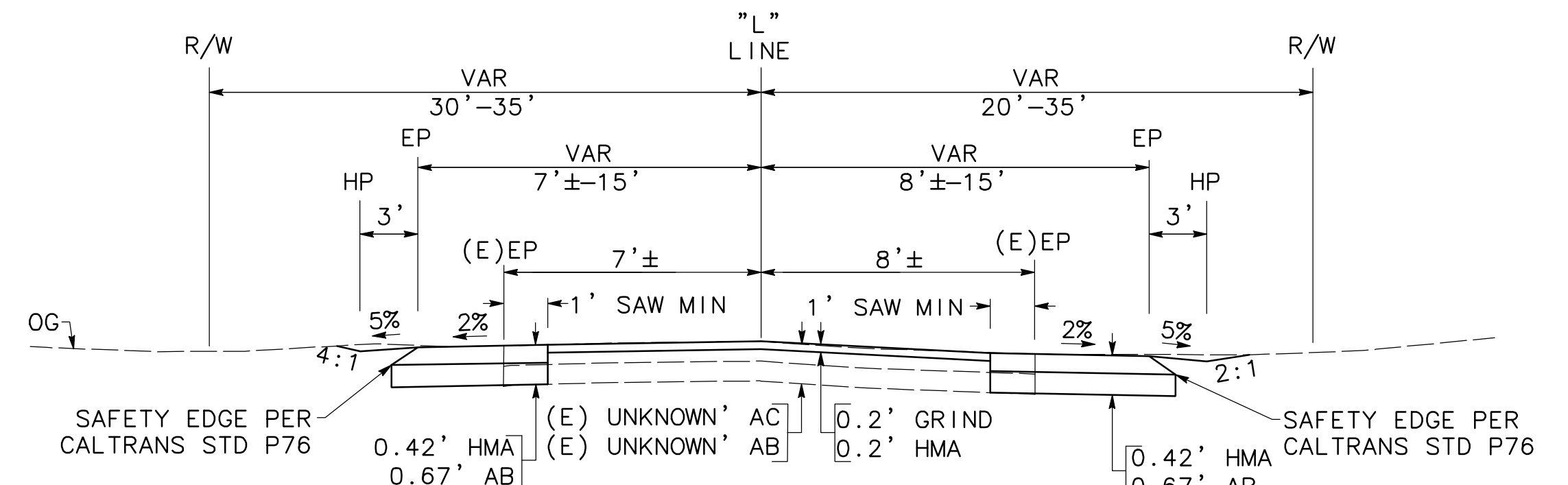

LINCOLN AVENUE

39+85.00 TO 41+62.08

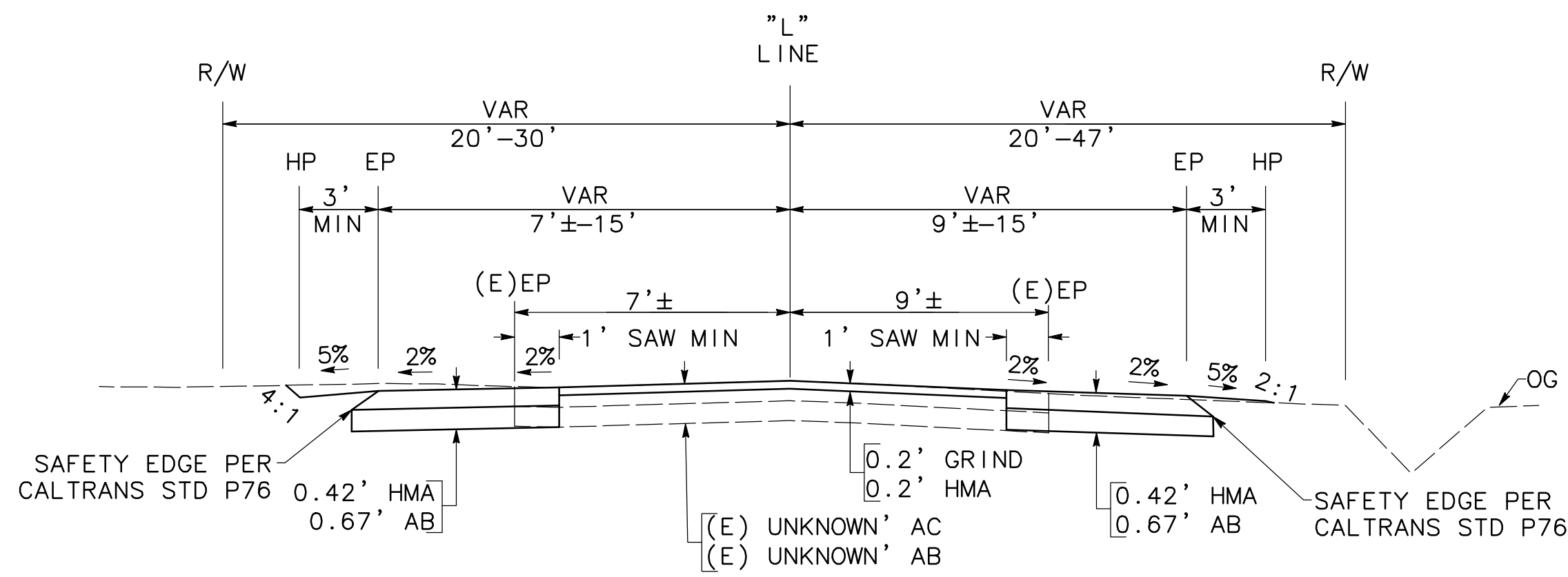

LINCOLN AVENUE

35+90.00 TO 38+75.00

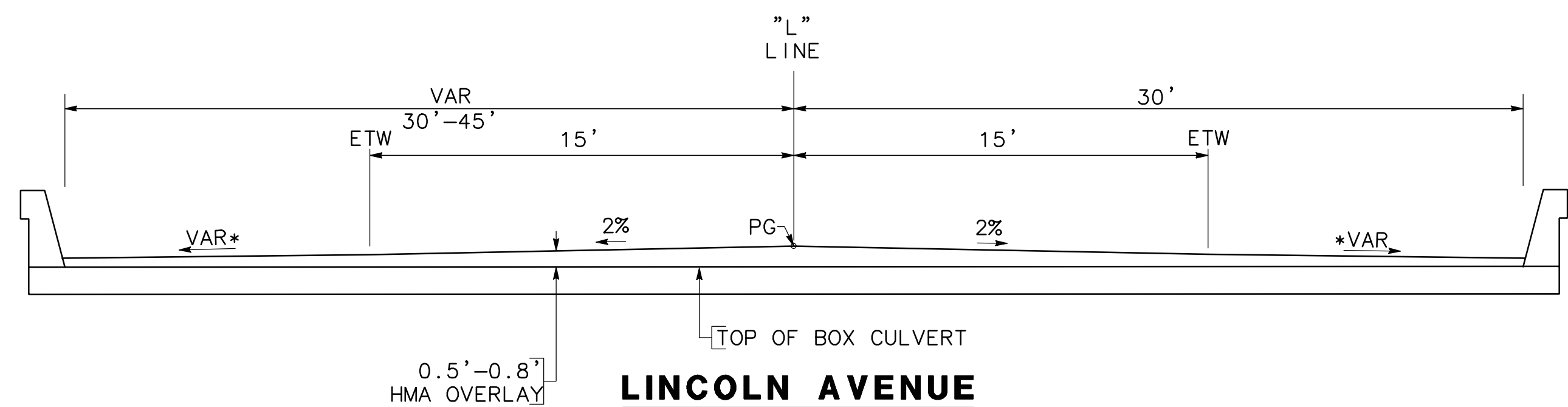

LINCOLN AVENUE

39+17.42 TO 39+41.69

*SEE CD-3 FOR SLOPES FROM EP TO BRIDGE BARRIER

DESIGNED: CL	DATE: 04/14/2023	RECORD DRAWING	SCALE		PROJECT		DEPARTMENT OF PUBLIC WORKS AND PLANNING
DRAWN: DA	DATE: 04/14/2023	RESIDENT ENGINEER			TRAVERS CREEK AT LINCOLN AVE		TRAVERS CREEK AT LINCOLN AVE
CHECKED: CH	DATE: 04/14/2023				COUNTY OF FRESNO, CA		TYPICAL SECTIONS
FOR RIGHT OF WAY DATA AND ACCURATE ACCESS DETERMINATION, SEE DOCUMENTS IN THE DEPARTMENT OF PUBLIC WORKS AND PLANNING.					ROAD NO. 4721	BRIDGE NO. 42C0683	DRAWING NO. X-2
							SHEET NO. 14
							TOTAL 40

GENERAL NOTES

1. CONTRACTORS SHALL COMPLY WITH BUSINESS AND PROFESSIONS CODE SECTION 8771(B) AND 8771(C) REGARDING REFERENCING, PRESERVING, AND RECONSTRUCTING MONUMENTS, WHETHER OR NOT MONUMENTS ARE SHOWN IN THESE PLANS.
2. CONTRACTOR SHALL PROVIDE THE ENGINEER A MINIMUM OF (2) WEEKS NOTICE PRIOR TO COMMENCING ANY WORK THAT COULD DAMAGE OR DESTROY ANY SURVEY MONUMENTS.
3. IF MONUMENT IS DAMAGED BY CONSTRUCTION OPERATIONS THE CONTRACTOR SHALL REPLACE AT THE CONTRACTORS COST.

BASIS OF BEARING:
 THE NORTH LINE OF THE NORTHEAST QUARTER OF SECTION 8, TOWNSHIP 15 SOUTH, RANGE 24 EAST, MOUNTAIN DIABLO BASELINE AND MERIDIAN, WAS TAKEN TO BEAR N90°00'00"E.

BASIS OF VERTICAL CONTROL:
 BENCHMARK LO 29, A CHISELED SQUARE LOCATED ON THE NORTHWEST CORNER OF THE SOUTHEAST CONCRETE WINGWALL, HAS AN NGVD29 ELEVATION OF 385.465 FEET PER FRESNO COUNTY BENCHMARK RECORDS.

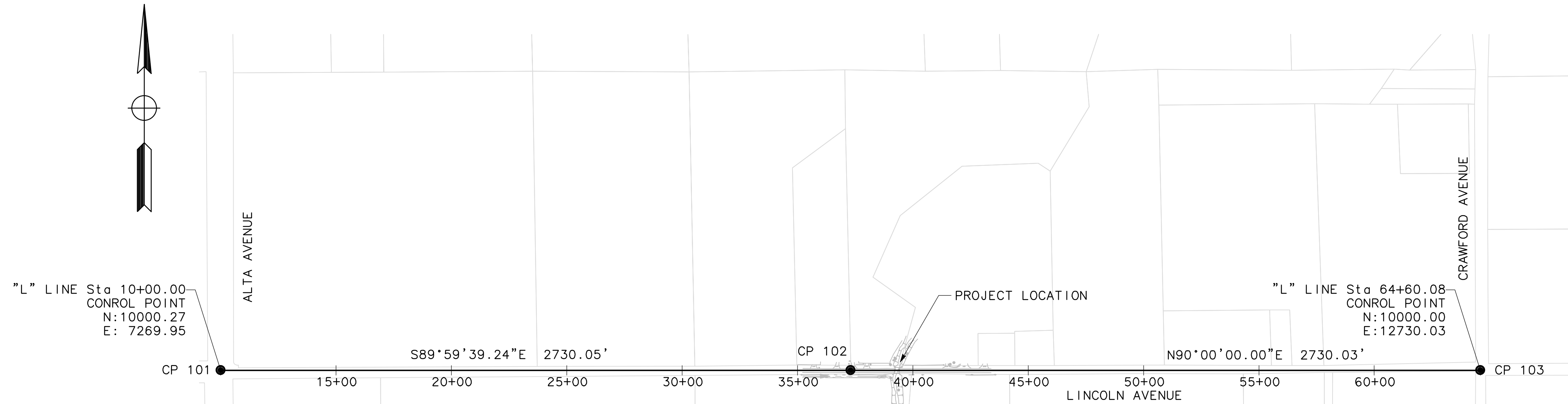

LEGEND







- FRESNO COUNTY CONTROL POINTS

CONTROL FOR DESIGN & CONSTRUCTION

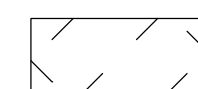
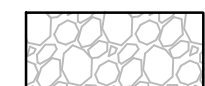
POINT	NORTHING	EASTING	ELEVATION	DESCRIPTION
101	10000.27	7269.95	382.34	Fd. FCBCM Dn. 5"
102	10000.00	10000.00	385.05	Fd. 2" IP Dn. 6"
103	10000.00	12730.03	388.87	Fd. Metal Disk W/Nut Dn. 20"

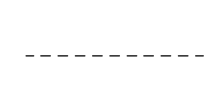
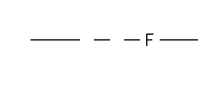
	DATE	RECORD DRAWING	SCALE		PROJECT	DEPARTMENT OF PUBLIC WORKS AND PLANNING	
DESIGNED: CL	04/14/2023	RESIDENT ENGINEER	 SCALE: 1" = 300'	_____ SUPERVISING ENGINEER	TRAVERS CREEK AT LINCOLN AVE COUNTY OF FRESNO, CA	TRAVERS CREEK AT LINCOLN AVE PROJECT CONTROL	
DRAWN: DA	04/14/2023			_____ DATE		ROAD NO. 4721	DRAWING NO. PC-2
CHECKED: CH	04/14/2023			BRIDGE NO. 42C0683		SHEET NO. 15	TOTAL 40
FOR RIGHT OF WAY DATA AND ACCURATE ACCESS DETERMINATION, SEE DOCUMENTS IN THE DEPARTMENT OF PUBLIC WORKS AND PLANNING.							

LEGEND

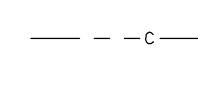
-  NEW PAVEMENT
-  GRIND/OVERLAY
-  ROCK SLOPE PROTECTION
-  REMOVE TREE
-  SAWCUT
-  FILL
-  AC PAVEMENT - DWY
-  HMA OVERLAY
-  CONCRETE
-  CUT

GENERAL NOTES

1. FOR CONTROL LINE & MONUMENT INFORMATION, SEE PC-2.
2. FOR SIGN AND STRIPING INFORMATION SEE, SS-2.
3. FOR BRIDGE INFORMATION SEE STRUCTURE SHEETS.
4. FOR GRADING INFORMATION SEE CD-3.
5. CONCRETE SLOPE PAVING BEHIND WING WALL 2' WIDE TO TOP OF CHANNEL AND 6" MAX DEEP AS DIRECTED BY THE COUNTY ENGINEER.

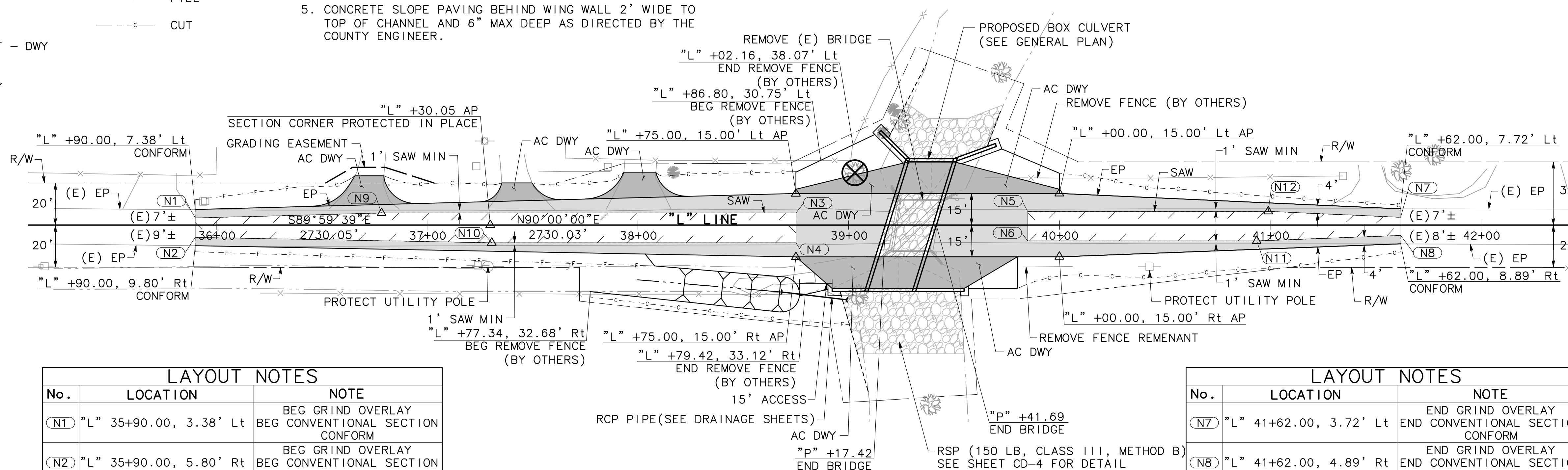



LAYOUT NOTES		
No.	LOCATION	NOTE
(N1)	"L" 35+90.00, 3.38' Lt	BEG GRIND OVERLAY BEG CONVENTIONAL SECTION CONFORM
(N2)	"L" 35+90.00, 5.80' Rt	BEG GRIND OVERLAY BEG CONVENTIONAL SECTION CONFORM
(N3)	"L" 38+75.00, 5.76' Lt	END GRIND OVERLAY BEG CONVENTIONAL SECTION CONFORM
(N4)	"L" 38+75.00, 8.36' Rt	END GRIND OVERLAY BEG CONVENTIONAL SECTION CONFORM
(N5)	"L" 39+85.00, 6.55' Lt	BEG GRIND OVERLAY END CONVENTIONAL SECTION
(N6)	"L" 39+85.00, 7.46' Rt	BEG GRIND OVERLAY END CONVENTIONAL SECTION

LAYOUT NOTES		
No.	LOCATION	NOTE
(N7)	"L" 41+62.00, 3.72' Lt	END GRIND OVERLAY END CONVENTIONAL SECTION CONFORM
(N8)	"L" 41+62.00, 4.89' Rt	END GRIND OVERLAY END CONVENTIONAL SECTION CONFORM
(N9)	"L" 36+78.47, 5.75' Lt	AP
(N10)	"L" 37+30.75, 8.36' Rt	AP
(N11)	"L" 40+93.70, 7.46' Rt	AP
(N12)	"L" 40+99.18, 6.55' Rt	AP

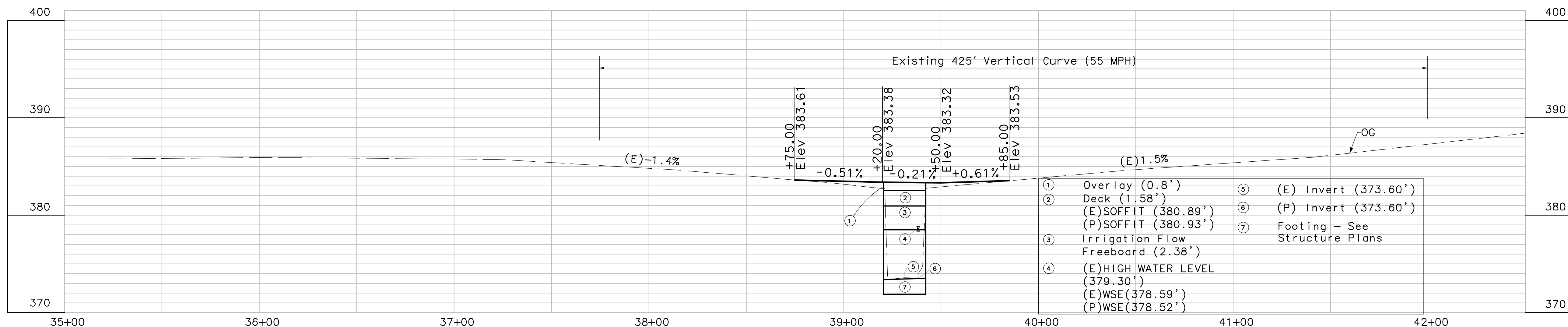
LINCOLN AVENUE
SCALE: 1" = 30'

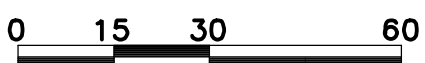

'L' LINE PROFILE
SCALE : H: 1"=30'
V: 1"=5'

DESIGNED: CL	DATE: 04/14/2023	RECORD DRAWING	SCALE		PROJECT		DEPARTMENT OF PUBLIC WORKS AND PLANNING
DRAWN: DA	DATE: 04/14/2023	RESIDENT ENGINEER			TRAVERS CREEK AT LINCOLN AVE		TRAVERS CREEK AT LINCOLN AVE
CHECKED: CH	DATE: 04/14/2023	DATE	SCALE: 1" = 30'		COUNTY OF FRESNO, CA		PLAN AND PROFILE
FOR RIGHT OF WAY DATA AND ACCURATE ACCESS DETERMINATION, SEE DOCUMENTS IN THE DEPARTMENT OF PUBLIC WORKS AND PLANNING.				SUPERVISING ENGINEER	ROAD NO. 4721	BRIDGE NO. 42C0683	DRAWING NO. PP-2
				DATE	SHEET NO. 16		TOTAL 40

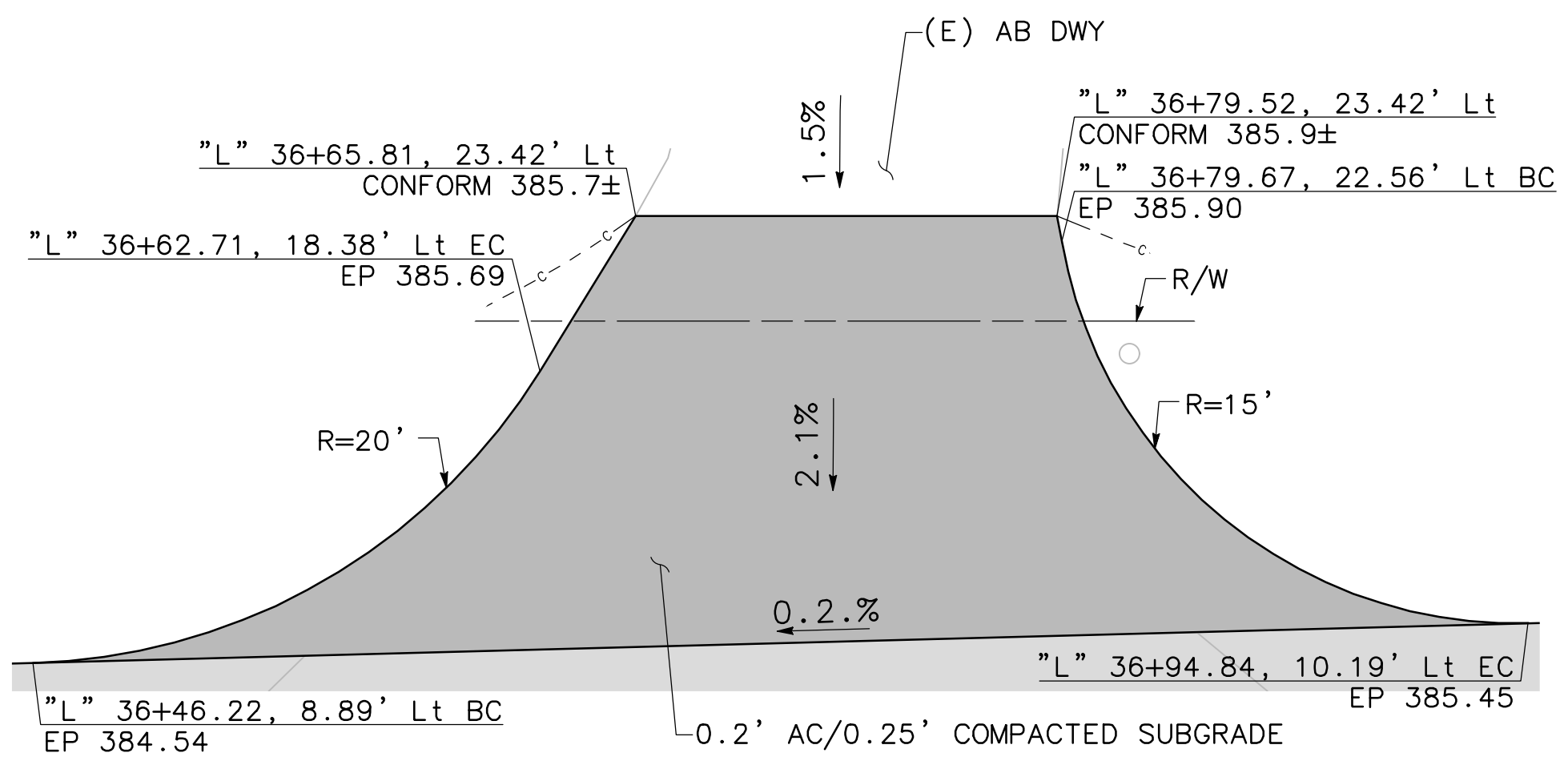
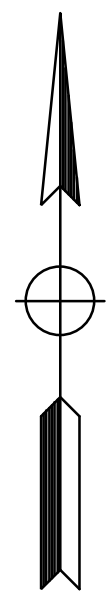

DETAIL "A"
SCALE: 1" = 5'

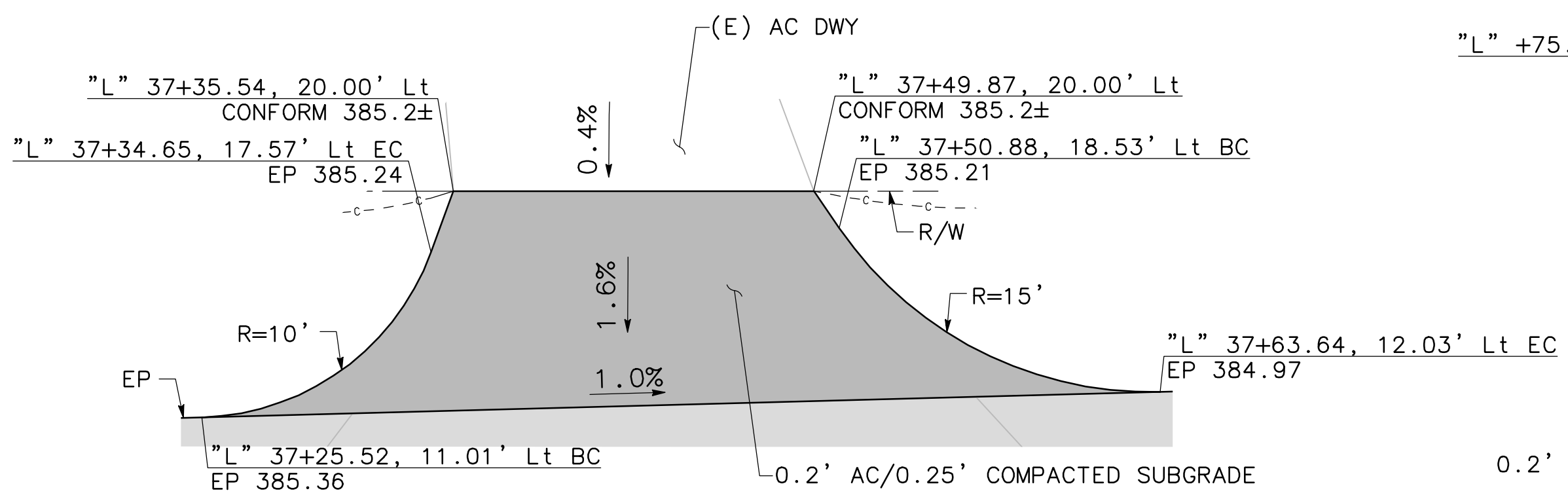

DETAIL "B"
SCALE: 1" = 5'

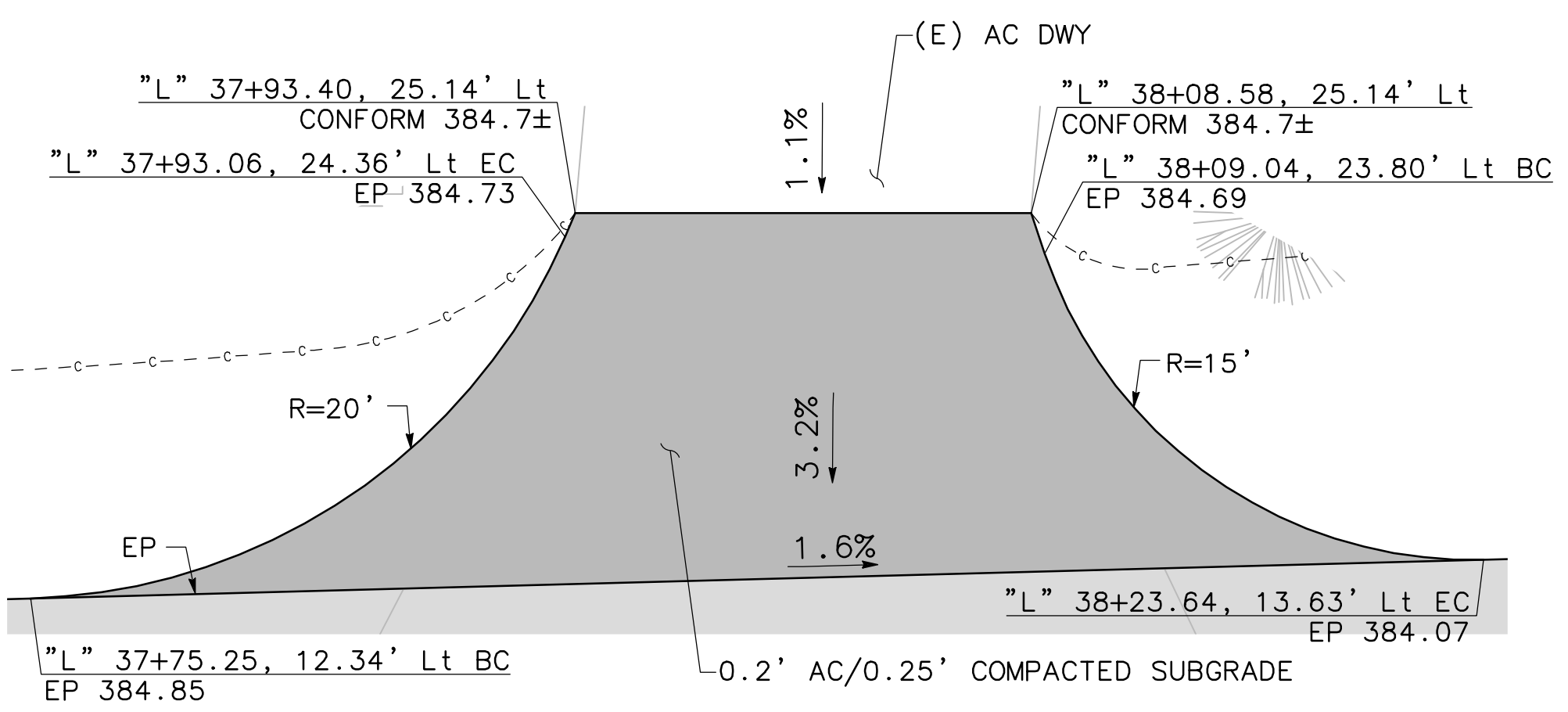

DETAIL "C"
SCALE: 1" = 5'

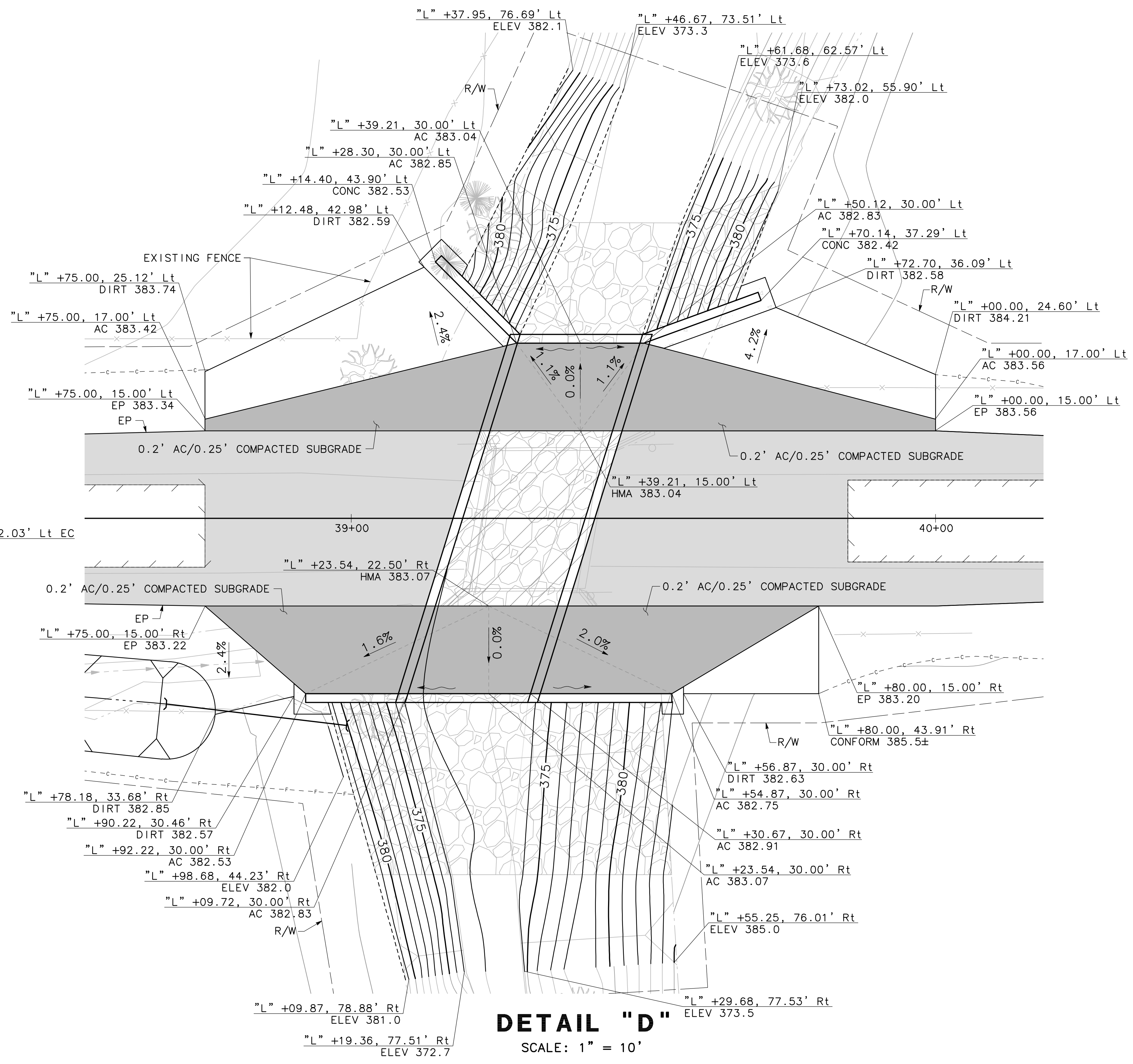

DETAIL "D"
SCALE: 1" = 10'

DESIGNED: CL		DATE: 04/14/2023	RECORD DRAWING		SCALE		PROJECT		DEPARTMENT OF PUBLIC WORKS AND PLANNING	
DRAWN: DA		DATE: 04/14/2023	RESIDENT ENGINEER		SCALE: 1" = 5'		TRAVERS CREEK AT LINCOLN AVE		TRAVERS CREEK AT LINCOLN AVE	
CHECKED: CH		DATE: 04/14/2023	DATE		SUPERVISING ENGINEER		COUNTY OF FRESNO, CA		CONSTRUCTION DETAILS	
FOR RIGHT OF WAY DATA AND ACCURATE ACCESS DETERMINATION, SEE DOCUMENTS IN THE DEPARTMENT OF PUBLIC WORKS AND PLANNING.							ROAD NO. 4721		DRAWING NO. CD-3	
							BRIDGE NO. 42C0683		SHEET NO. 17	
									TOTAL 40	

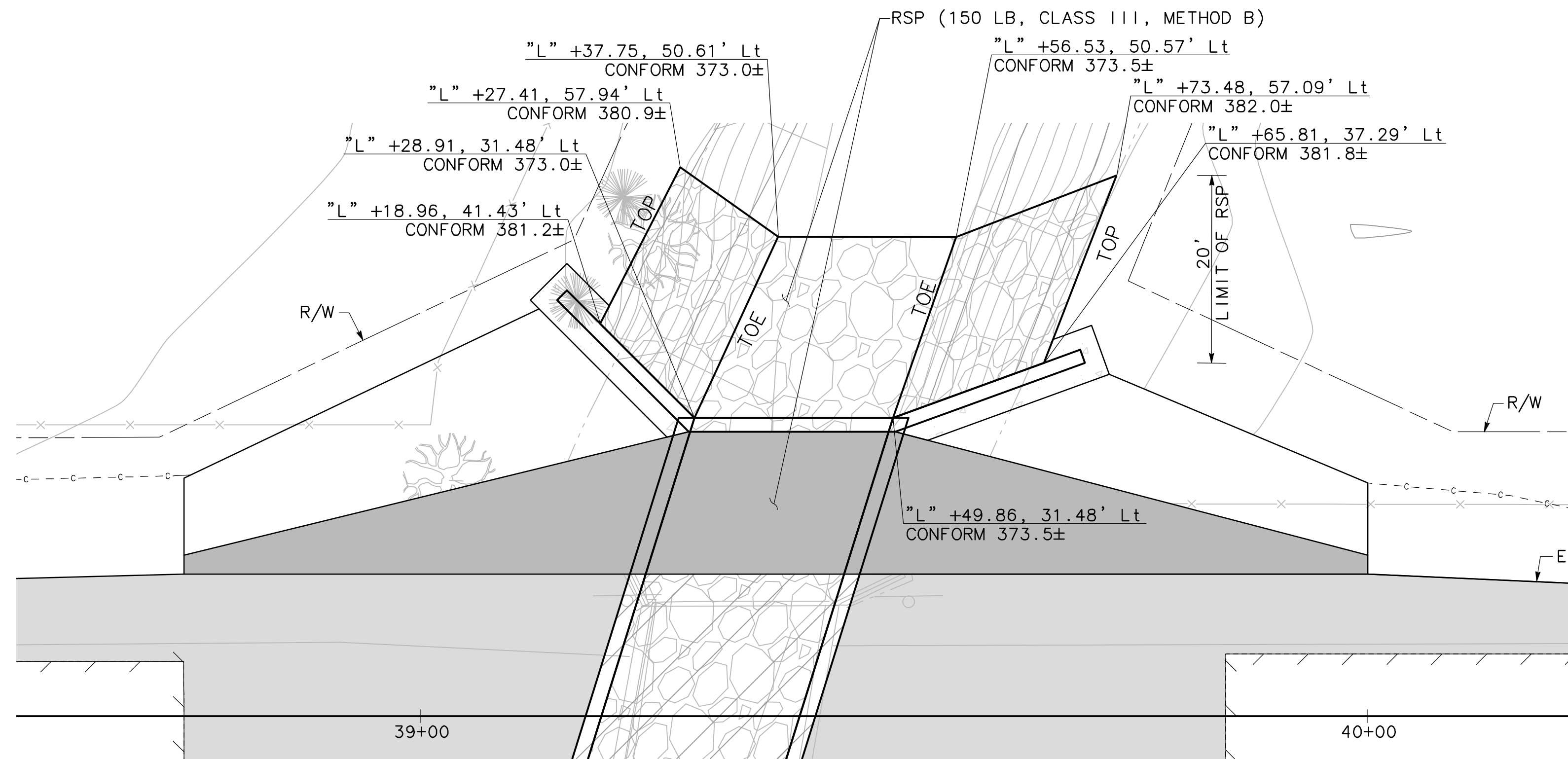

DETAIL "E"

SCALE: 1" = 10'

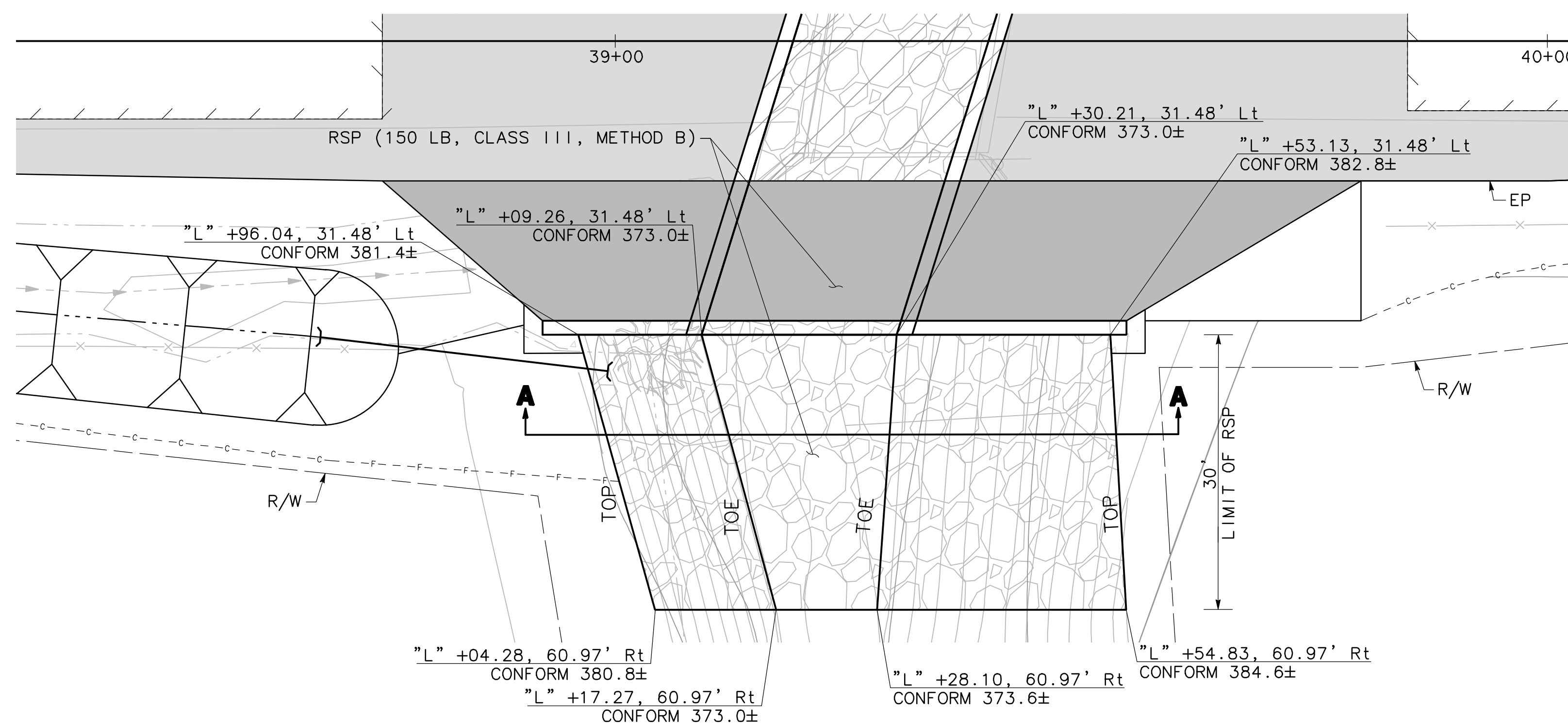

DETAIL "F"

SCALE: 1" = 10'

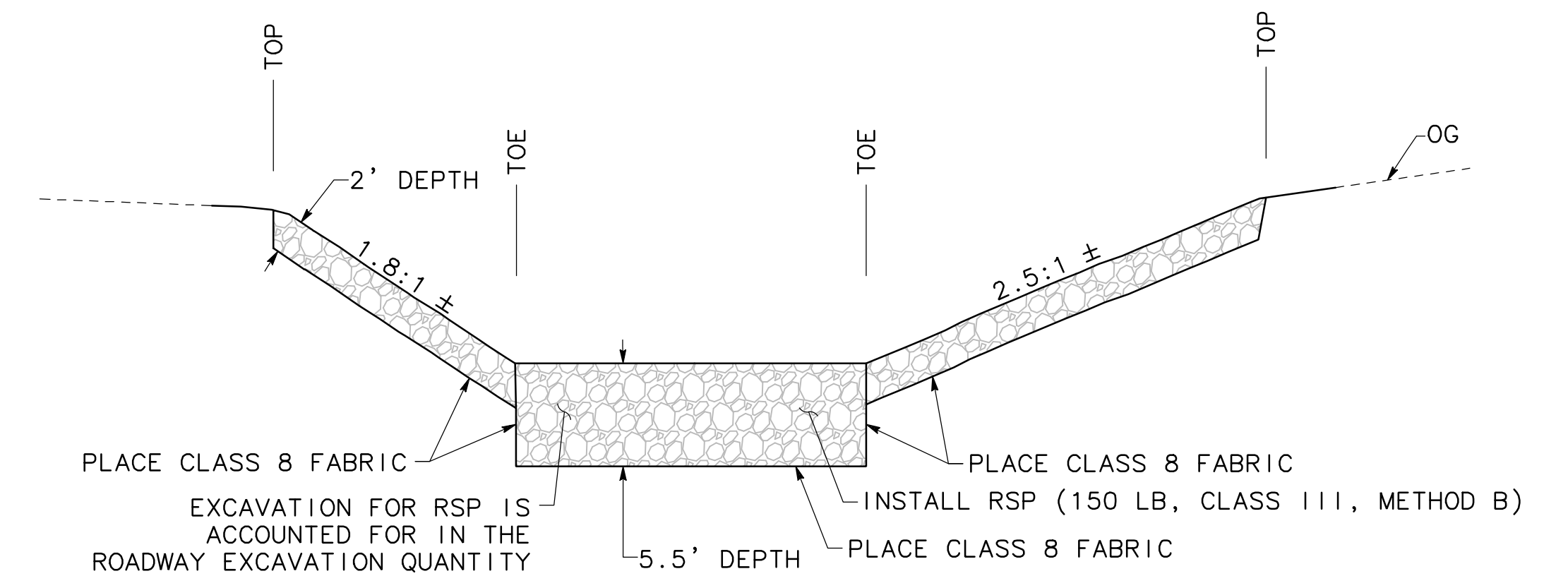

SECTION A-A

NTS

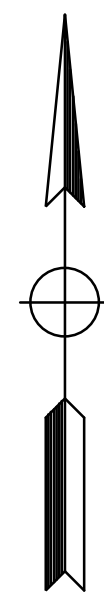

DESIGNED: CL	DATE: 04/14/2023	RECORD DRAWING		SCALE	 SCALE: 1" = 5'		PROJECT		DEPARTMENT OF PUBLIC WORKS AND PLANNING	
DRAWN: DA	DATE: 04/14/2023	RESIDENT ENGINEER	DATE	SUPERVISING ENGINEER			DATE		TRAVERS CREEK AT LINCOLN AVE	TRAVERS CREEK AT LINCOLN AVE
CHECKED: CH	DATE: 04/14/2023								COUNTY OF FRESNO, CA	CONSTRUCTION DETAILS
FOR RIGHT OF WAY DATA AND ACCURATE ACCESS DETERMINATION, SEE DOCUMENTS IN THE DEPARTMENT OF PUBLIC WORKS AND PLANNING.										
						ROAD NO. 4721	BRIDGE NO. 42C0683	DRAWING NO. CD-4	SHEET NO. 18	TOTAL 40

GENERAL NOTES

LOCATIONS FOR EXISTING UNDERGROUND FACILITIES ARE APPROXIMATE. EXACT DEPTH AND LOCATIONS ARE UNKNOWN. FIELD LOCATE PRIOR TO THE START OF CONSTRUCTION.

**CALL UNDERGROUND SERVICE ALERT (USA) 811

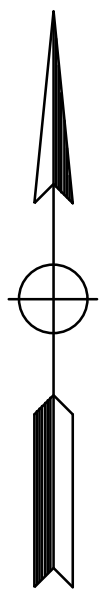
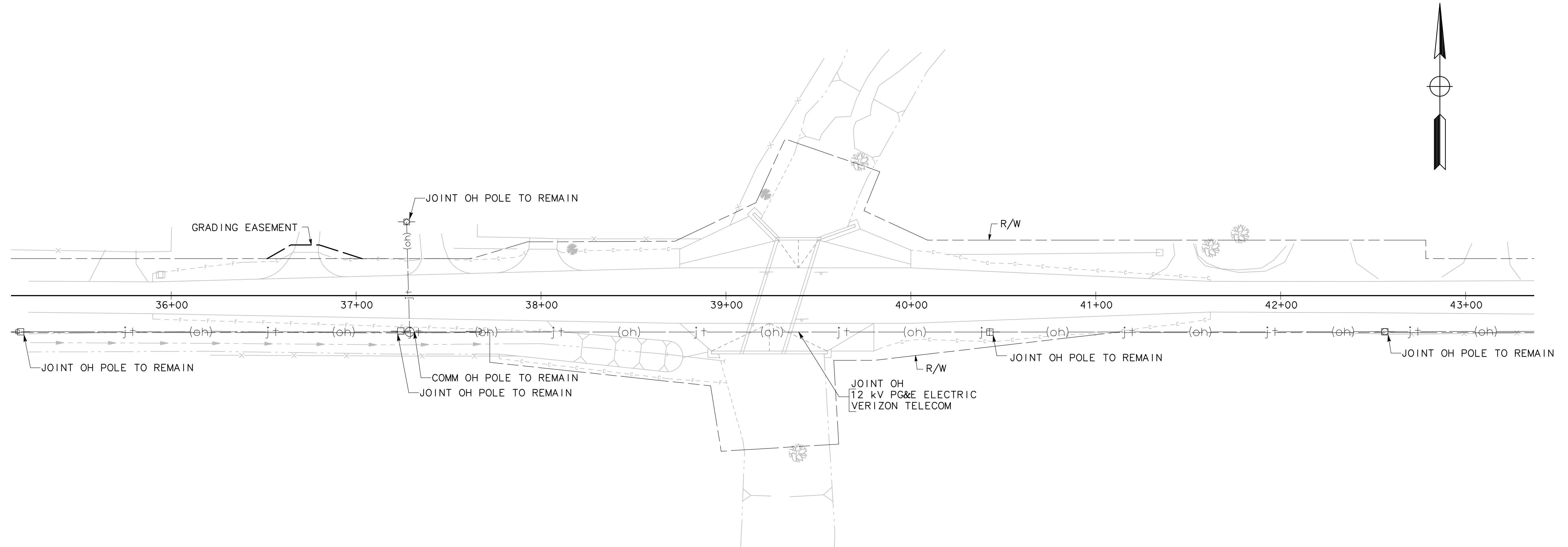

LINCOLN AVENUE
SCALE: 1" = 30'

DESIGNED: CL	DATE: 04/14/2023	RECORD DRAWING		SCALE		PROJECT		DEPARTMENT OF PUBLIC WORKS AND PLANNING		
DRAWN: DA	DATE: 04/14/2023	RESIDENT ENGINEER	DATE	0 15 30 60		TRAVERS CREEK AT LINCOLN AVE		TRAVERS CREEK AT LINCOLN AVE		
CHECKED: CH	DATE: 04/14/2023			SCALE: 1" = 30'		COUNTY OF FRESNO, CA		UTILITY PLAN		
FOR RIGHT OF WAY DATA AND ACCURATE ACCESS DETERMINATION, SEE DOCUMENTS IN THE DEPARTMENT OF PUBLIC WORKS AND PLANNING.				SUPERVISING ENGINEER	DATE	ROAD NO. 4721	BRIDGE NO. 42C0683	DRAWING NO. U-2	SHEET NO. 19	TOTAL 40

GENERAL NOTES

1. WORK SHALL BE DONE IN ACCORDANCE WITH THE 2015 STANDARD PLANS AND SPECIFICATIONS OF THE STATE OF CALIFORNIA DEPARTMENT OF TRANSPORTATION, SIGN SPECIFICATION SHEETS, THE 2014 CALIFORNIA MANUAL ON UNIFORM TRAFFIC CONTROL DEVICES (CA MUTCD), AND THE SPECIAL PROVISIONS.
2. THESE SIGNING AND STRIPING PLANS ARE ACCURATE FOR SIGNING AND PAVEMENT MARKINGS ONLY. ALL REFERENCE TO PAVEMENT MARKINGS SHALL INCLUDE STRIPING.
3. ALL SALVAGED MATERIAL SHALL BE DELIVERED TO THE COUNTY SIGN SHOP (BUILDING 409) AT 4551 E. HAMILTON AVENUE. THE CONTRACTOR SHALL NOTIFY THE SIGN SHOP (559)600-7899 AT LEAST TWO WORKING DAYS PRIOR TO DELIVERY.
4. ALL EXISTING PAVEMENT MARKING WHICH CONFLICTS WITH PROPOSED PAVEMENT MARKING SHALL BE REMOVED.
5. ALL EXISTING SIGNS NOT SHOWN ON THE PLANS TO REMAIN OR BE RELOCATED SHALL REMAIN, BE SALVAGED, OR RELOCATED AS DIRECTED BY THE ENGINEER.
6. SIGNS SHALL BE TYPE iv OR ix RETROREFLECTIVE SHEETING IN ACCORDANCE WITH ASTM 4956-09. ALL SIGNS SHALL BE COVERED WITH A TRANSLUCENT ANTI-GRAFFITI FLUOROPOLYMER FILM THAT DOES NOT IMPAIR THE REFLECTIVITY OF THE SIGN.

LEGEND:

- ┆ EXISTING SIGN
- ┆ PROPOSED SINGLE POST ROADSIDE SIGN
- REMOVE ROADSIDE SIGN

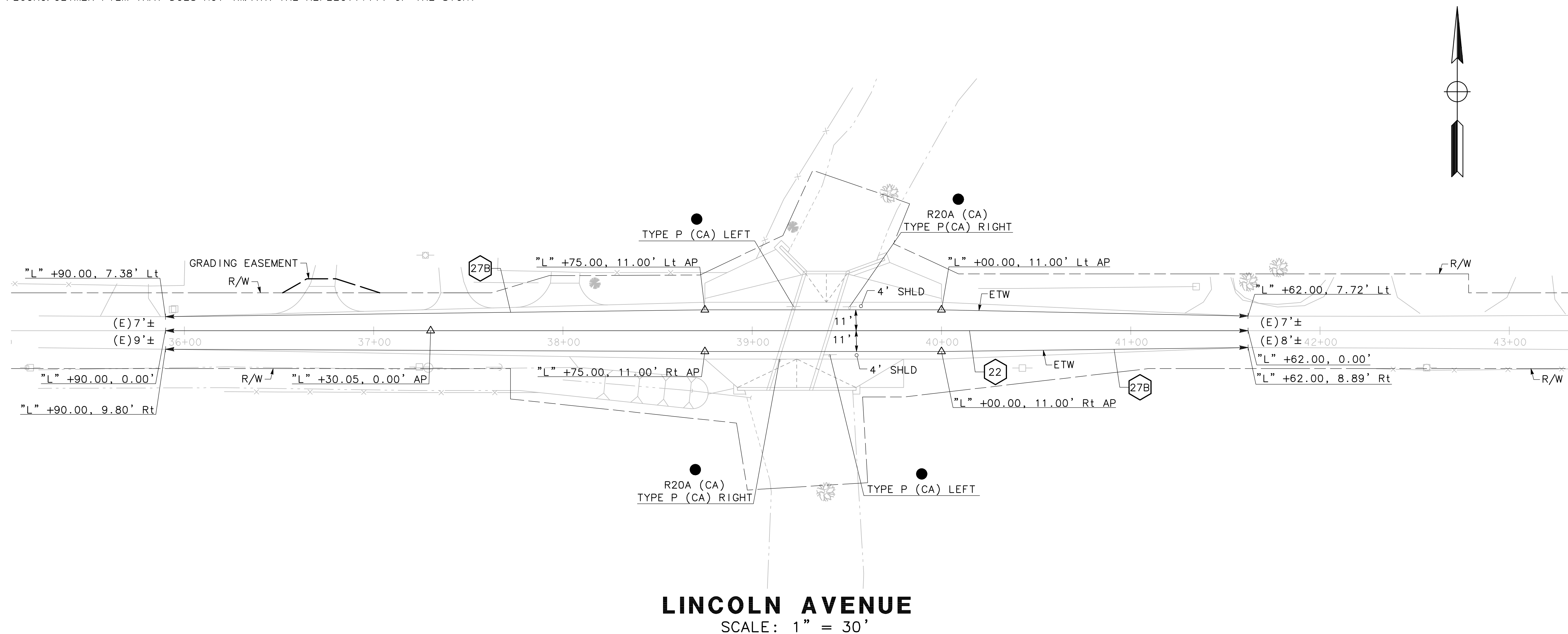

	DATE	RECORD DRAWING	SCALE		PROJECT		<i>DEPARTMENT OF PUBLIC WORKS AND PLANNING</i>
DESIGNED: CL	04/14/2023	RESIDENT ENGINEER	 SCALE: 1" = 30'		TRAVERS CREEK AT LINCOLN AVE		TRAVERS CREEK AT LINCOLN AVE
DRAWN: DA	04/14/2023			SUPERVISING ENGINEER _____ DATE _____	COUNTY OF FRESNO, CA		SIGNING AND STRIPING PLAN
CHECKED: CH	04/14/2023			ROAD NO. 4721 BRIDGE NO. 42C0683	DRAWING NO. SS-2 SHEET NO. 20 TOTAL 40		

FOR RIGHT OF WAY DATA AND ACCURATE ACCESS DETERMINATION, SEE DOCUMENTS IN THE DEPARTMENT OF PUBLIC WORKS AND PLANNING.

STATIONARY MOUNTED CONSTRUCTION AREA SIGNS

SIGN LETTER	SIGN CODE	PANEL SIZE	SIGN MESSAGE	EACH (N)
(A)	M4-8A	24"x18"	END DETOUR	2
(B)	M4-9(L)	30"x24"	DETOUR WITH ARROW (LEFT)	4
(C)	M4-9(R)	30"x24"	DETOUR WITH ARROW (RIGHT)	5
(D)	M4-10(R)	48"x18"	DETOUR ARROW (RIGHT)	1
(E)	M4-10(L)	48"x18"	DETOUR ARROW (LEFT)	2
(F)	R3-1	24"x24"	NO RIGHT TURN SYMBOL	2
(G)	R11-2	48"x30"	ROAD CLOSED	2
(H)	R11-4	60"x30"	ROAD CLOSED TO THRU TRAFFIC	2
(I)	SC3(CA)	36"x12"	DETOUR WITH ARROW (STRAIGHT)	10
(J)	W20-1	36"x36"	ROAD WORK AHEAD	2
(K)	W20-3	36"x36"	ROAD CLOSED AHEAD	2
(L)	R3-2	24"x24"	NO LEFT TURN SYMBOL	2
(M)	CUSTOM	54"x36"	EB LINCOLN AVE CLOSED FOLLOW DETOUR	3
(N)	CUSTOM	54"x36"	WB LINCOLN AVE CLOSED FOLLOW DETOUR	3
TOTAL				42

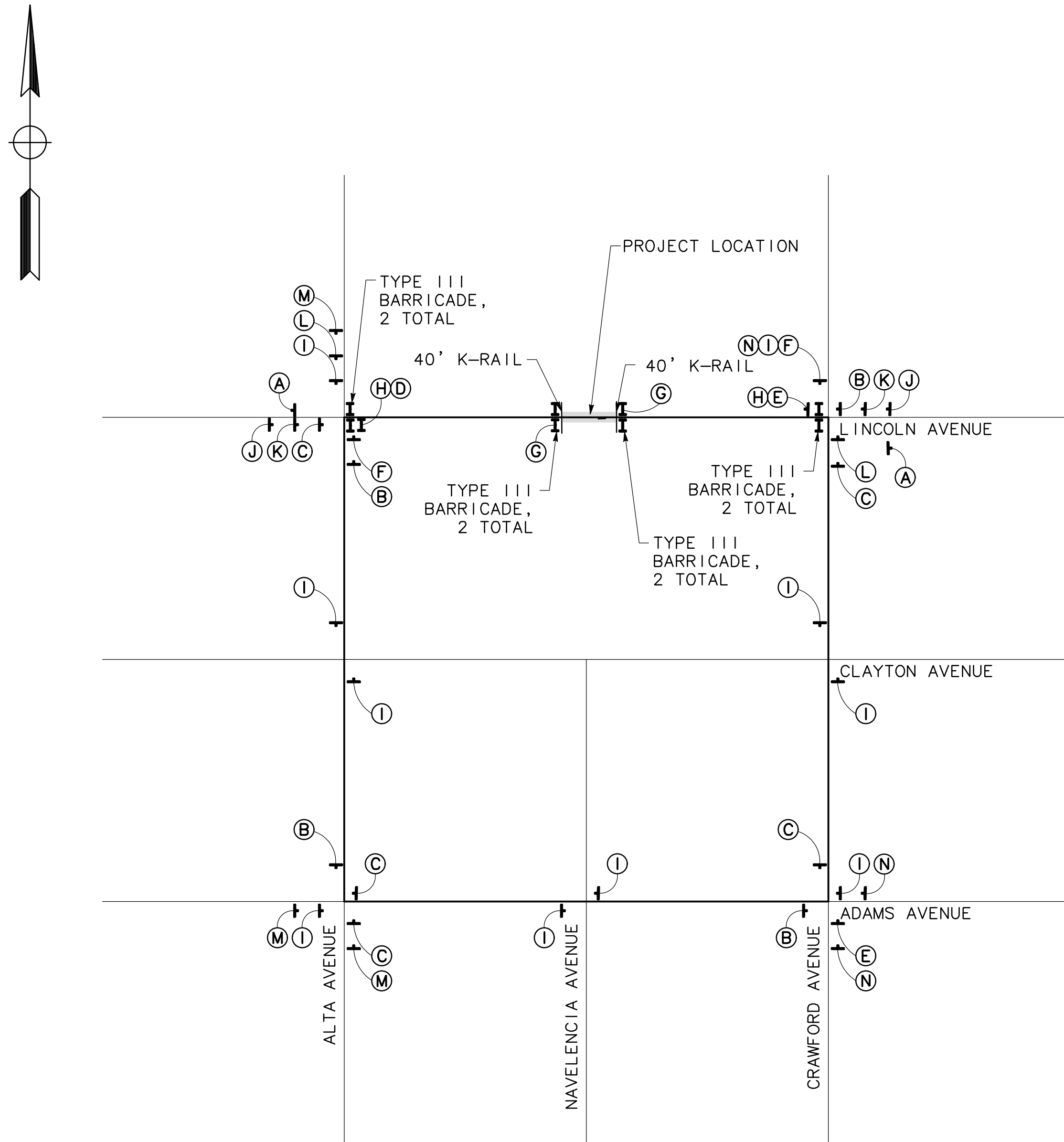

GENERAL NOTES

- LOCATION OF CONSTRUCTION AREA/DETOUR SIGNS SHOWN ARE APPROXIMATE. EXACT SIGN LOCATION IS TO BE DETERMINED BY THE ENGINEER.
- ALL TRAFFIC CONTROL DEVICES, BARRIERS, SIGNS, PAVEMENT MARKINGS, AND CHANNELIZATION DEVICES SHALL CONFORM TO THE MOST RECENT VERSION OF THE CA MUTCD.
- FOR SIGN SPACING, REFER TO 2014 CA MUTCD (REV 2) TABLE 6H-3. REFER 2014 CA MUTCD FOR MEANING OF LETTER CODES ON TYPICAL APPLICATION DIAGRAMS.
- CONTRACTOR TO PROVIDE REASONABLE MEANS FOR PROPERTY OWNERS ADJACENT CONSTRUCTION TO ACCESS PROPERTIES AT ALL TIMES.
- CONTRACTOR TO COORDINATE ANY DRIVEWAY CLOSURES WITH PROPERTY OWNERS BEFORE REMOVING ACCESS.
- THIS PLAN DOES NOT RELIEVED THE CONTRACTOR OF HIS RESPONSIBILITY TO PROVIDE A TRAFFIC CONTROL PLANS AS REQUIRED IN THE SPECIFICATIONS.
- ADDITIONAL TEMPORARY TRAFFIC DEVICES MAY BE REQUIRED AS PART OF THE TRAFFIC CONTROL SYSTEM PLAN AS DETERMINED BY THE ENGINEER.

	DATE	RECORD DRAWING	SCALE		PROJECT		<i>DEPARTMENT OF PUBLIC WORKS AND PLANNING</i>
DESIGNED: CL	04/14/2023	RESIDENT ENGINEER	<p>SCALE: 1" = 1000'</p>	_____ SUPERVISING ENGINEER DATE	TRAVERS CREEK AT LINCOLN AVE COUNTY OF FRESNO, CA		TRAVERS CREEK AT LINCOLN AVE TRAFFIC DETOUR PLAN
DRAWN: DA	04/14/2023				ROAD NO. 4721 BRIDGE NO. 42C0683		DRAWING NO. TD-2 SHEET NO. 21 TOTAL 40
CHECKED: CH	04/14/2023						

FOR RIGHT OF WAY DATA AND ACCURATE ACCESS DETERMINATION, SEE DOCUMENTS IN THE DEPARTMENT OF PUBLIC WORKS AND PLANNING.

LEGEND:

 ROCK SLOPE PROTECTION

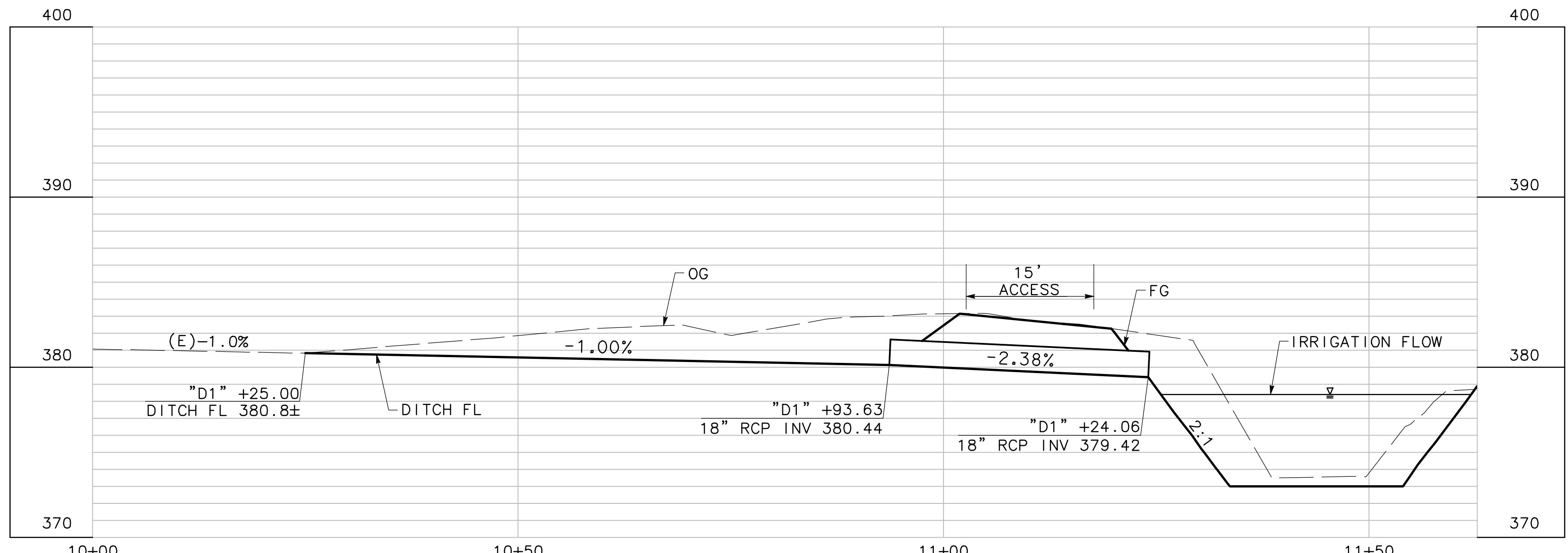
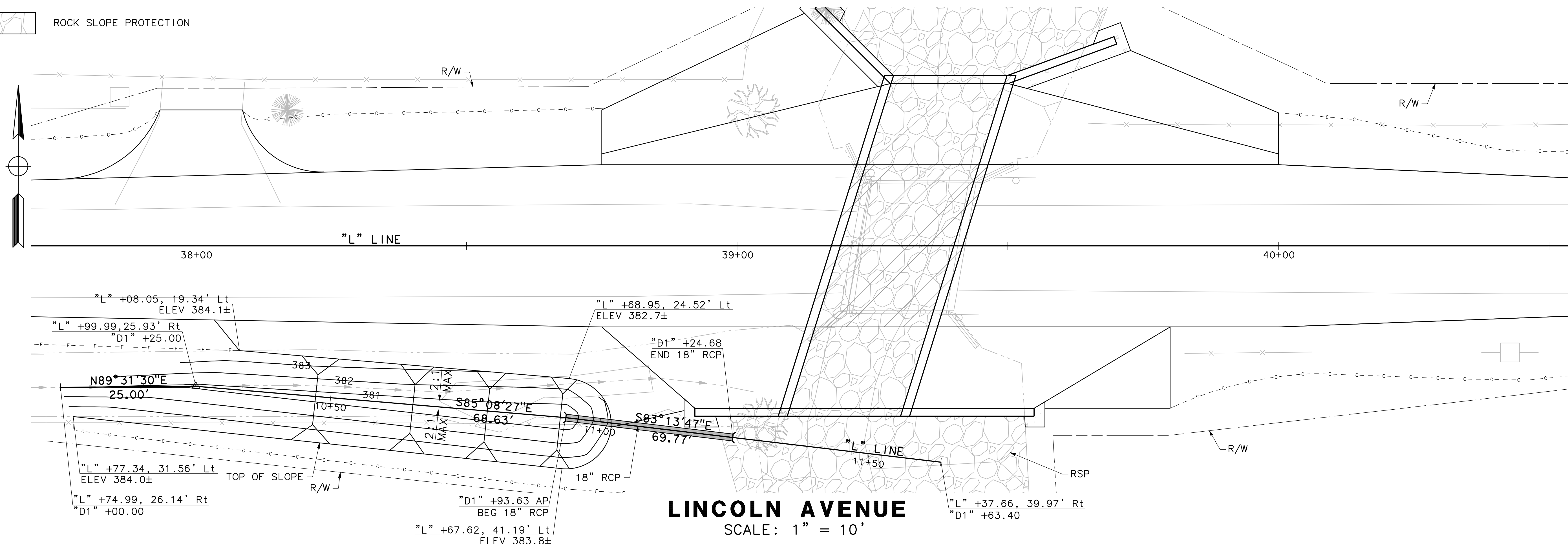

DITCH PROFILE
SCALE : H: 1"=10'
V: 1"=5'

	DATE	RECORD DRAWING		SCALE		PROJECT	DEPARTMENT OF PUBLIC WORKS AND PLANNING
DESIGNED: CL	04/14/2023	RESIDENT ENGINEER	DATE	0 5 10 20		TRAVERS CREEK AT LINCOLN AVE	TRAVERS CREEK AT LINCOLN AVE
DRAWN: DA	04/14/2023			SCALE: 1" = 10'	SUPERVISING ENGINEER	COUNTY OF FRESNO, CA	DRAINAGE PLAN
CHECKED: CH	04/14/2023				DATE	ROAD NO. 4721	DRAWING NO. D-1
FOR RIGHT OF WAY DATA AND ACCURATE ACCESS DETERMINATION, SEE DOCUMENTS IN THE DEPARTMENT OF PUBLIC WORKS AND PLANNING.						BRIDGE NO. 42C0683	SHEET NO. 22
						COUNTY OF FRESNO	TOTAL 40

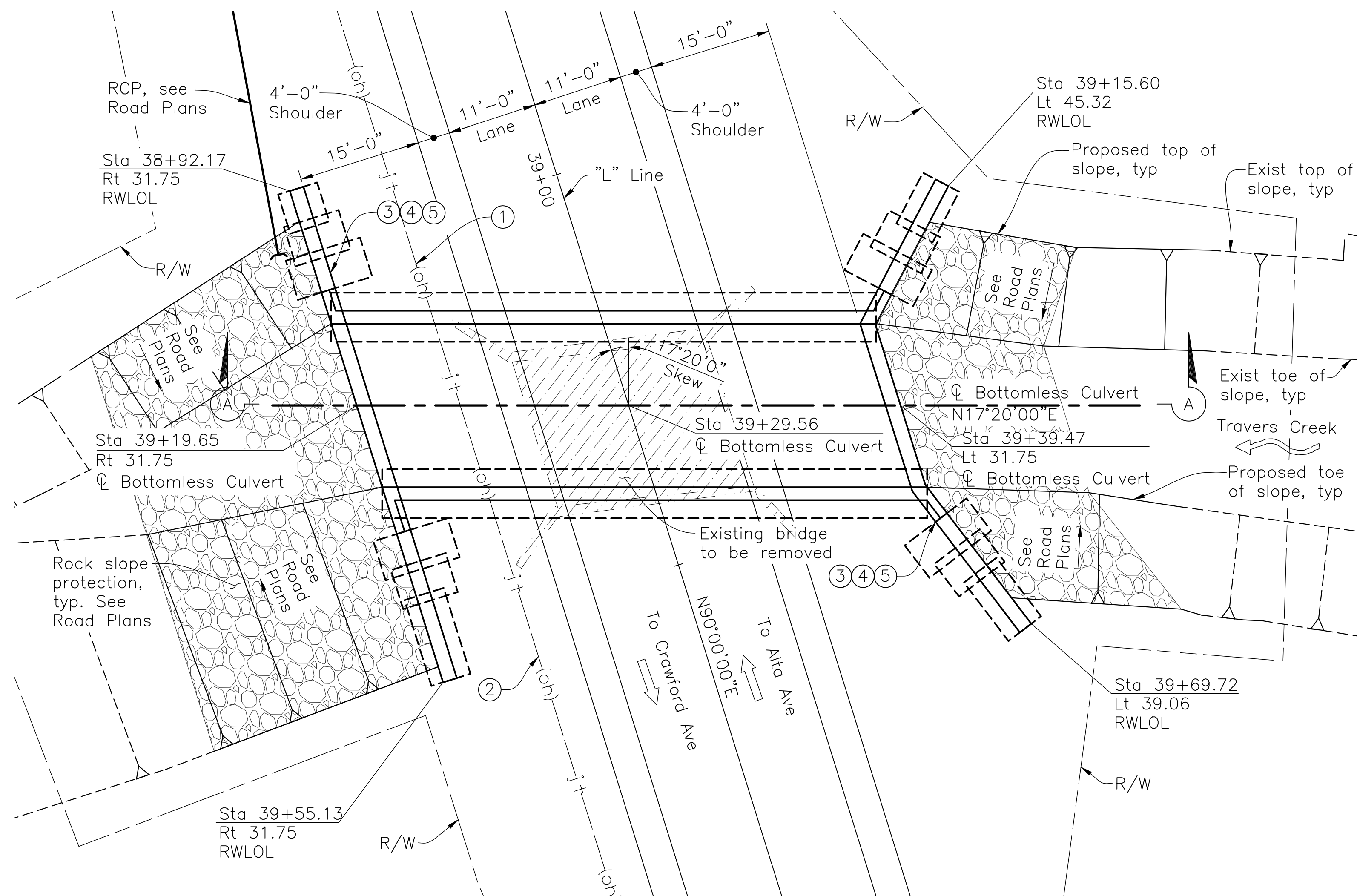

PLAN
1"=10'-0"

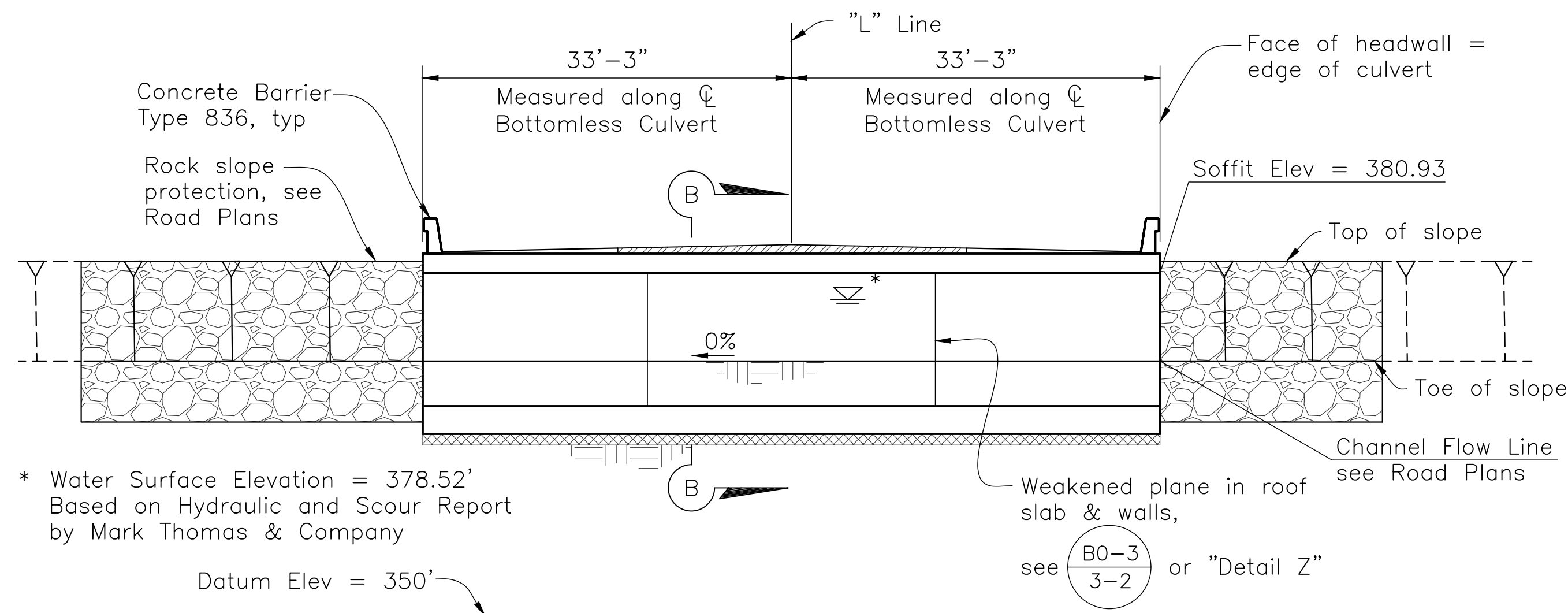

* Water Surface Elevation = 378.52'
Based on Hydraulic and Scour Report
by Mark Thomas & Company

LONGITUDINAL SECTION A-A
1"=10'-0"

Legend:

- RWLOL Indicates retaining wall layout line
- R/W Indicates right of way
- ① Existing overhead electricity line
- ② Existing overhead telephone line
- ③ Paint "Travers Creek"
- ④ Paint "State Br. No. 420683"
- ⑤ Paint "County Br. No. 10-065"
- ➔ Indicates direction of traffic
- Indicates existing structure to be removed
- Indicates rock slope protection, see Road Plans
- Indicates lean concrete or crushed gravel backfill
- Indicates asphalt concrete overlay
- Indicates Caltrans Standard Plan sheet no.
- Indicates detail no.

- Note:**
- For "Section B-B" see CIP BOTTOMLESS CULVERT DETAILS sheet
 - For "Detail Z" see CIP BOTTOMLESS CULVERT DETAILS sheet

DESIGNED_MAW	DATE 11/10/17
DRAWN_TZE	DATE 11/10/17
CHECKED_JPJ	DATE 11/10/17

Scale	AS SHOWN
-------	----------

CORNERSTONE
structural engineering group

986 W Alluvial Ave - Suite 201
Fresno, California 93711
559.320.3200
fax 559.320.3201

FOR R/W DATA AND ACCURATE ACCESS DETERMINATION SEE R/W RECORDS AT PUBLIC WORKS



PROJECT	TRAVERS CREEK AT LINCOLN AVE COUNTY OF FRESNO, CA
Road No. 4721	Bridge No. 42C0683



DEPARTMENT OF PUBLIC WORKS & PLANNING
TRAVERS CREEK AT LINCOLN AVE GENERAL LAYOUT
Drawing No. S-5 Sheet No. 23 of 40

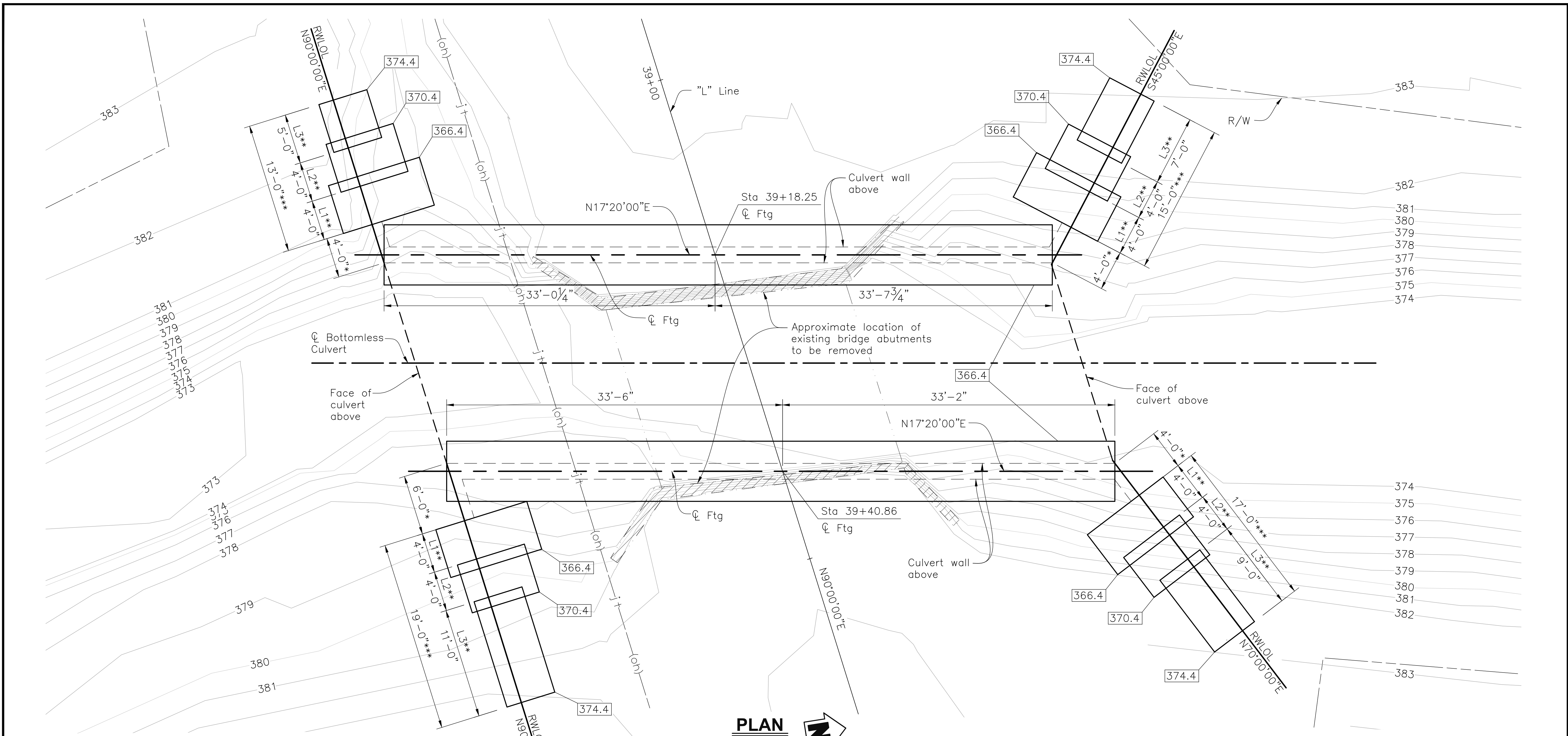

Notes:

1. 366.4 Indicates bottom of footing elevation.
2. -380- Indicates contour elevation.
3. Indicates existing structure to be removed.
4. Contractor shall verify all existing controlling field dimensions before ordering or fabricating any material.
5. Contours shown indicate existing conditions. For finished grade limits, see Road Plans.
6. * Indicates length of headwall measured along RWLOL, see "Section C-C" on CIP BOTTOMLESS CULVERT DETAILS sheet.
7. ** See "Retaining Wall Elevation" on CIP BOTTOMLESS CULVERT DETAILS sheet.
8. *** Indicates length of retaining wall measured along RWLOL.

DESIGNED_MAW	DATE
DRAWN_TZE	11/10/17
CHECKED_JPJ	11/10/17

Scale
AS SHOWN

CORNERSTONE
structural engineering group

986 W Alluvial Ave - Suite 201
Fresno, California 93711
559.320.3200
fax 559.320.3201

FOR R/W DATA AND ACCURATE ACCESS DETERMINATION SEE R/W RECORDS AT PUBLIC WORKS



PROJECT
TRAVERS CREEK AT LINCOLN AVE COUNTY OF FRESNO, CA
Road No. 4721 Bridge No. 42C0683



DEPARTMENT OF PUBLIC WORKS & PLANNING
TRAVERS CREEK AT LINCOLN AVE FOUNDATION PLAN
Drawing No. S-6 Sheet No. 24 of 40

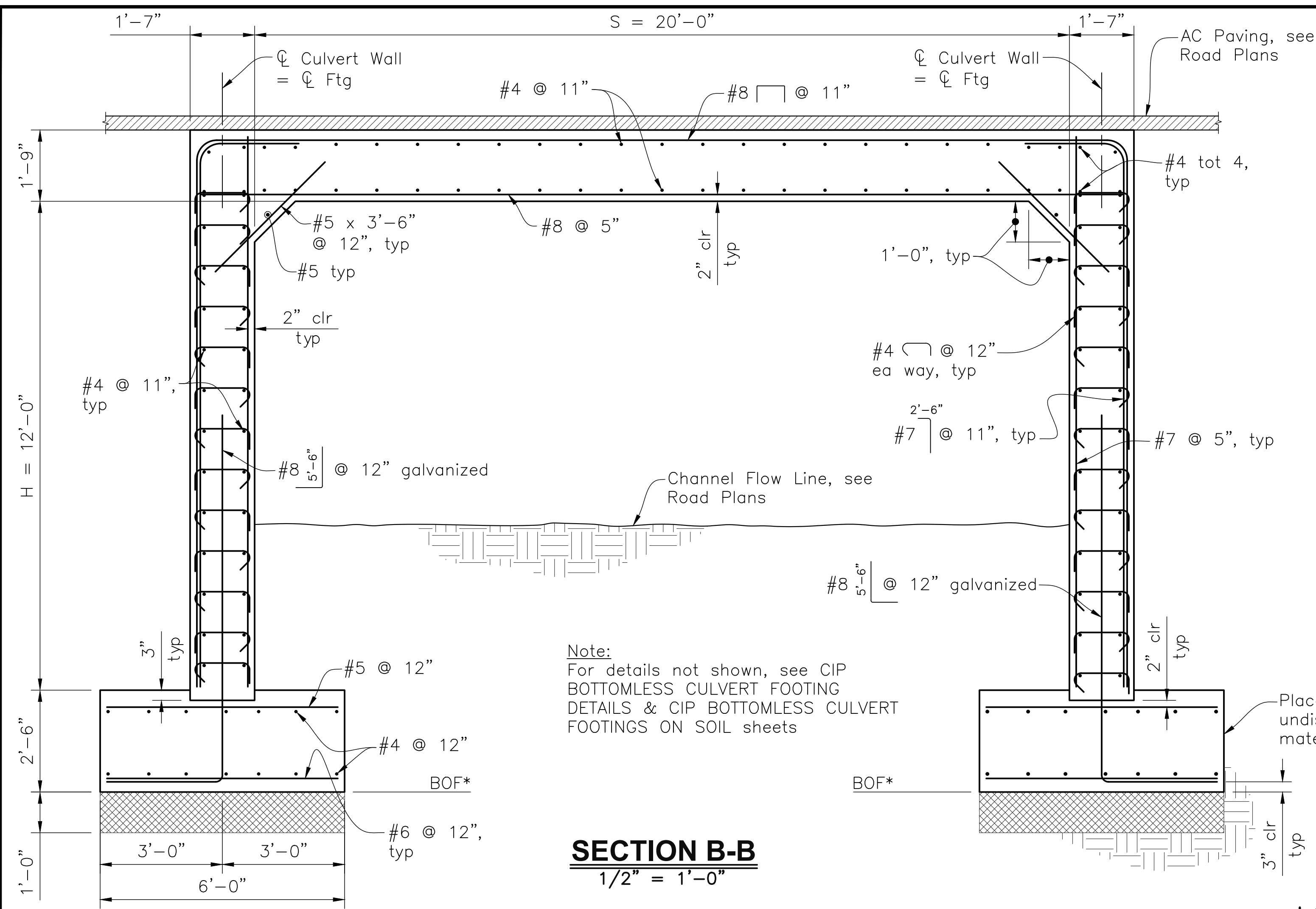

Note:
For details not shown, see CIP BOTTOMLESS CULVERT FOOTING DETAILS & CIP BOTTOMLESS CULVERT FOOTINGS ON SOIL sheets

SECTION B-B
1/2" = 1'-0"

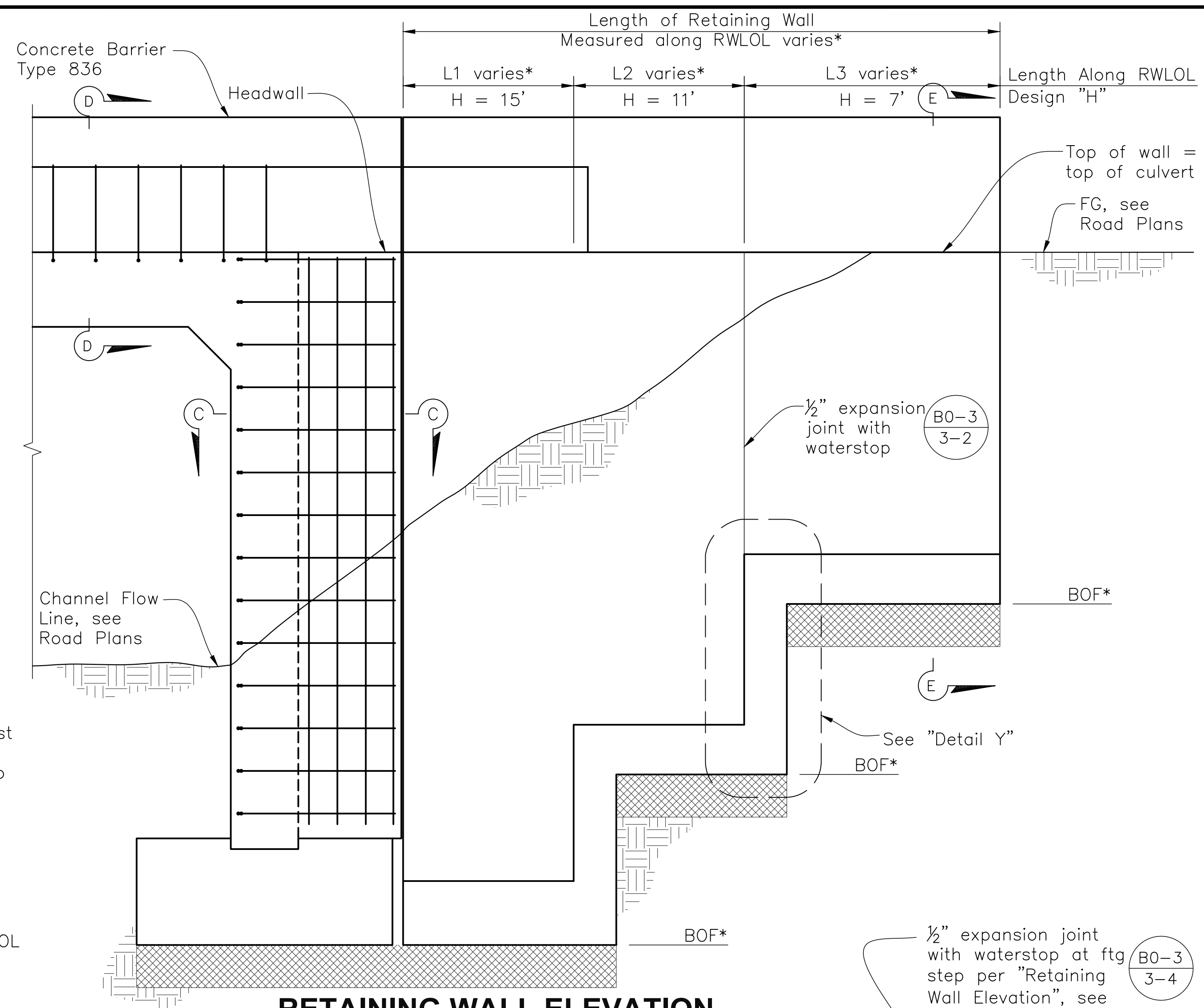

RETAINING WALL ELEVATION
1/2" = 1'-0"

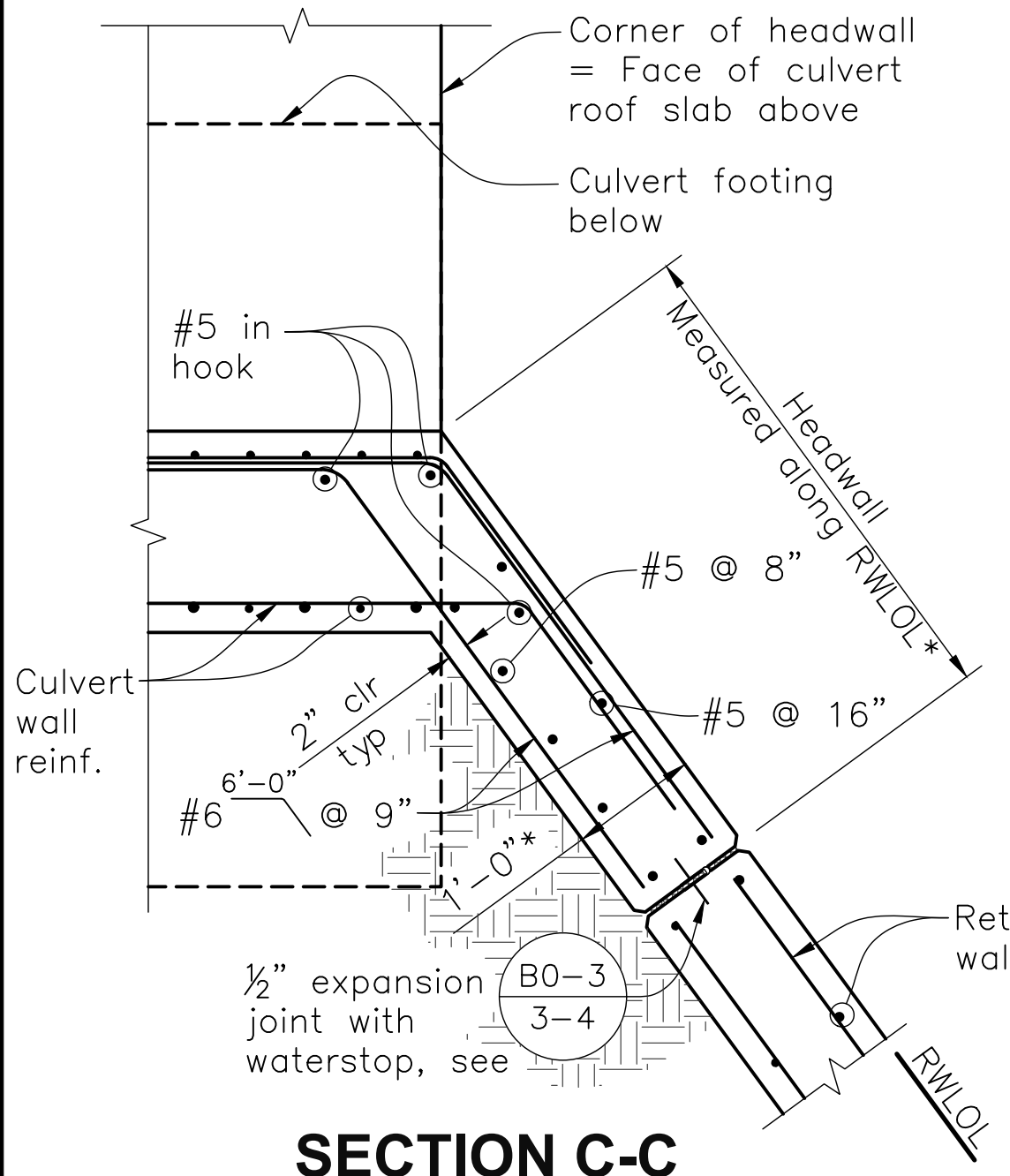

SECTION C-C
3/4" = 1'-0"

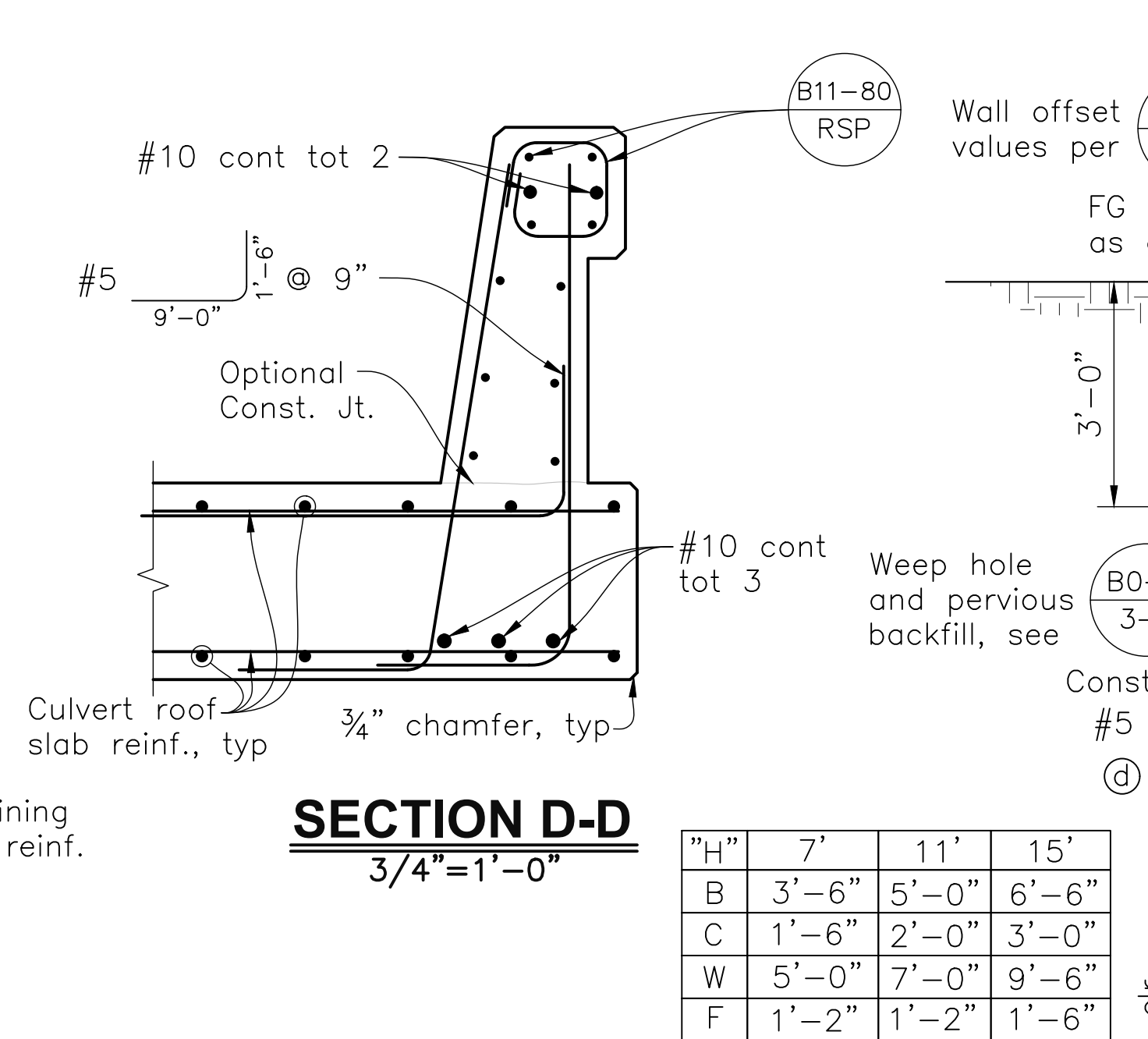

SECTION D-D
3/4" = 1'-0"

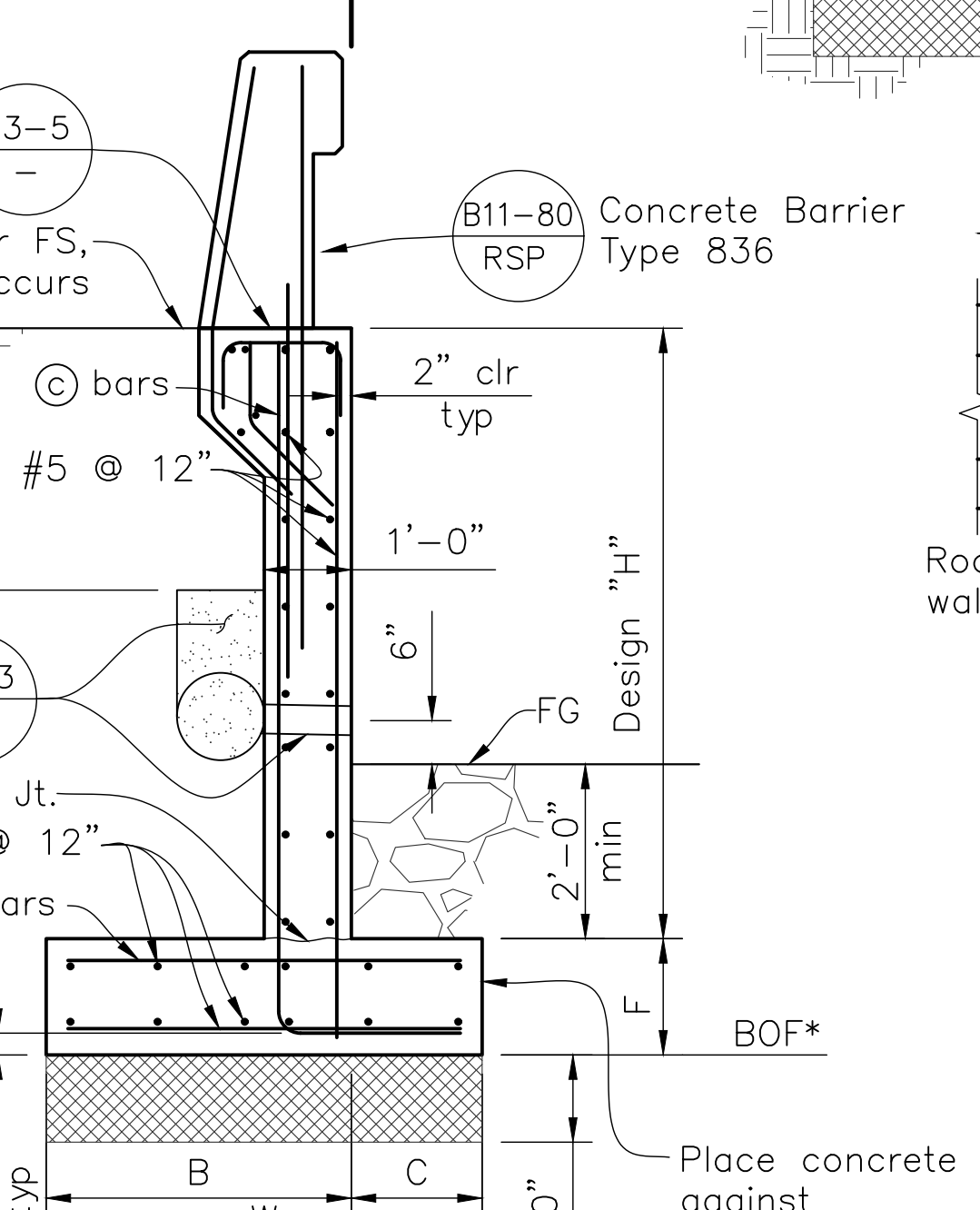

SECTION E-E
1/2" = 1'-0"

"H"	7'	11'	15'
B	3'-6"	5'-0"	6'-6"
C	1'-6"	2'-0"	3'-0"
W	5'-0"	7'-0"	9'-6"
F	1'-2"	1'-2"	1'-6"
⊙	#7@4"	#7@4"	#8@5"
⊕	#7@8"	#7@8"	#8@10"

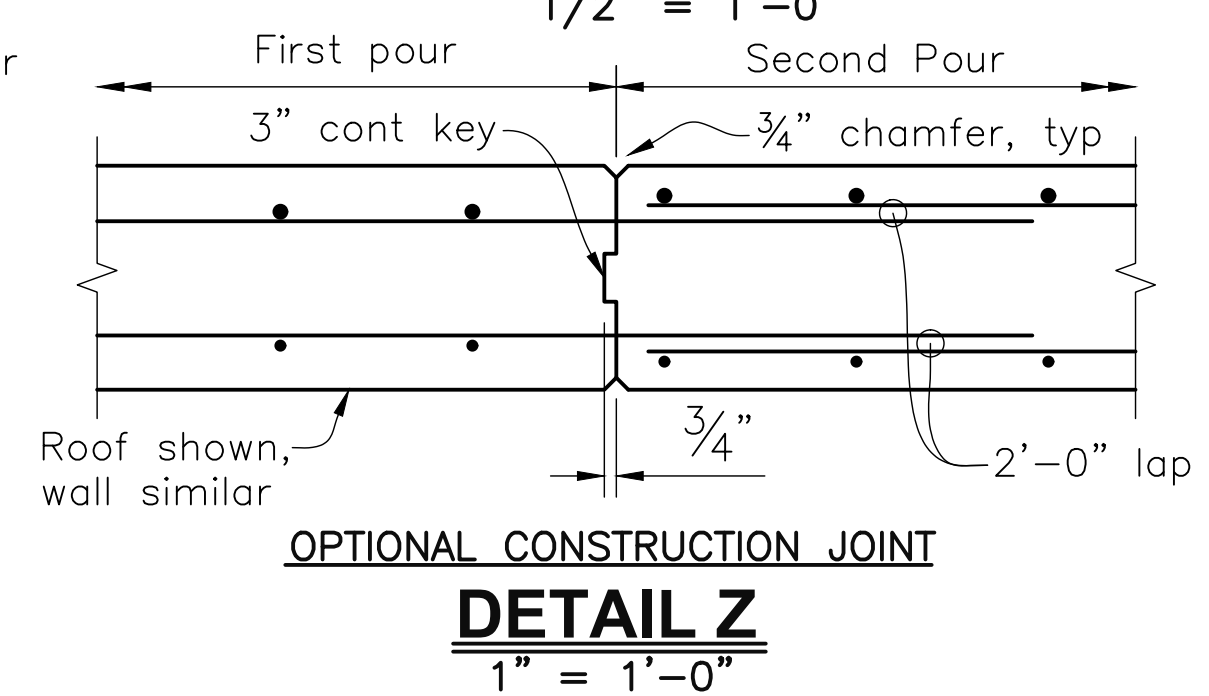

OPTIONAL CONSTRUCTION JOINT DETAIL Z
1" = 1'-0"

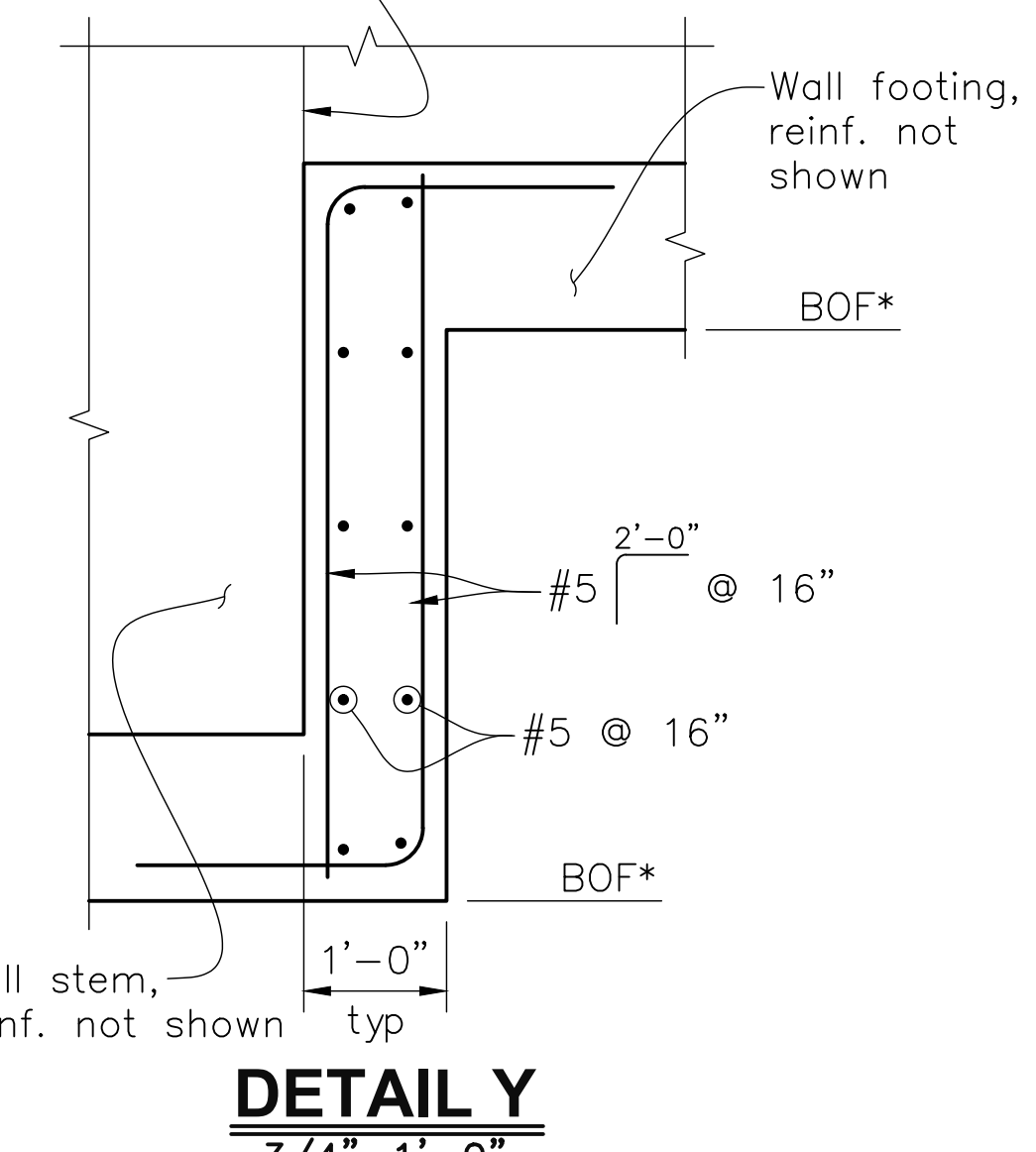

DETAIL Y
3/4" = 1'-0"

General Notes:
* See FOUNDATION PLAN sheet
BOF Indicates bottom of footing elevation
RWLOL Indicates retaining wall layout line
Indicates rip-rap, see Road Plans
Indicates lean concrete or crushed gravel backfill

DESIGNED	DATE
MAW	11/10/17
DRAWN	TZE
CHECKED	JPU
	11/10/17

Scale
AS SHOWN

CORNERSTONE
structural engineering group
986 W Alluvial Ave - Suite 201
Fresno, California 93711
559.320.3200
fax 559.320.3201

PROJECT
TRIVERS CREEK AT LINCOLN AVE
COUNTY OF FRESNO, CA
Road No. 4721 Bridge No. 42C0683



DEPARTMENT OF PUBLIC WORKS & PLANNING
CIP BOTTOMLESS CULVERT DETAILS
Drawing No. S-7 Sheet No. 25 of 40

DESIGN NOTES:

1. Specifications:

AASHTO LRFD Bridge Design Specifications, 6th Edition with California Amendments.

Loading:

Impact Factor (Apply to roof slab only):
 $IM = 33(1.0 - 0.125 D_E) \geq 0\%$
 D_E - the minimum depth of earth cover

Earth Load:

Earth pressures for two conditions:
 For culverts with pile foundation or footing on rock
 140 LB/CF vertical, 42 LB/CF horizontal.
 140 LB/CF vertical, 140 LB/CF horizontal.
 For culverts with footing on soil
 140 LB/CF vertical, 42 LB/CF horizontal.
 140 LB/CF vertical, 70 LB/CF horizontal.

Unit stresses:

$f'_c = 3600$ psi (Culverts & Footings)
 $f'_c = 4000$ psi (Piles)
 $f_y = 60,000$ psi

2. Piles:

Class 200 kip pile in Standard Plans B2-8 for deep foundation.

CONSTRUCTION NOTES:

Construction loads:

Strutting required as shown on Standard Plan D88. Strutting may be required on culvert extensions when existing parapet is removed.

Roof and Walls:

When cover is less than span length- Place $\frac{1}{2}$ " premolded expansion joint filler at $30'-0"$ centers outside the paved roadway lanes and place Bridge Detail 3-2, Standard Plan B0-3, at $30'-0"$ centers under paved roadway lanes.

When cover is more than span length- Place $\frac{1}{2}$ " premolded expansion joint filler at $30'-0"$ centers and additional $\frac{1}{2}$ " premolded expansion joints at locations of change in foundation character as directed by the engineer.

Construction joints:

Temporary joints permitted if normal (or radial) to ϕ of frame.

GENERAL NOTES:

Reinforcement placement:

Main reinforcement is to be placed transversely or, for curved culverts, radially. When radial, reinforcing spacing of the transverse bars in the top slab is measured along the centerline.

Provide paving notch when top is exposed and when pavement is portland cement concrete, see "WALL, SLAB, AND PILE DETAILS" sheet for details.

For design and details not shown, see Standard Plans D82 and D84.

NOTE:
 THE CONTRACTOR MUST VERIFY ALL CONTROLLING FIELD DIMENSIONS BEFORE ORDERING OR FABRICATING ANY MATERIAL.

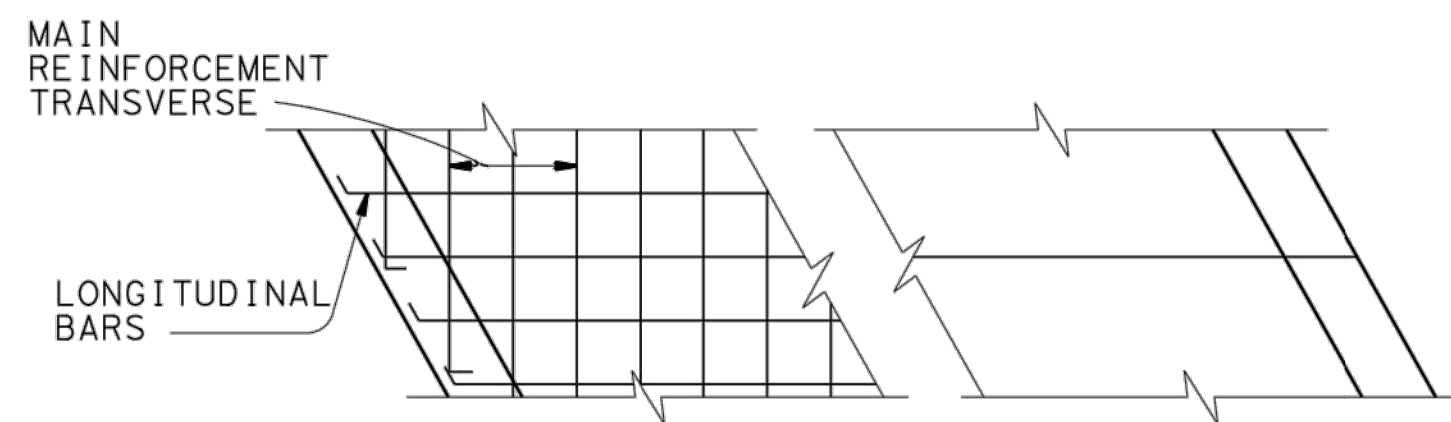

PART PLAN-SKEWED

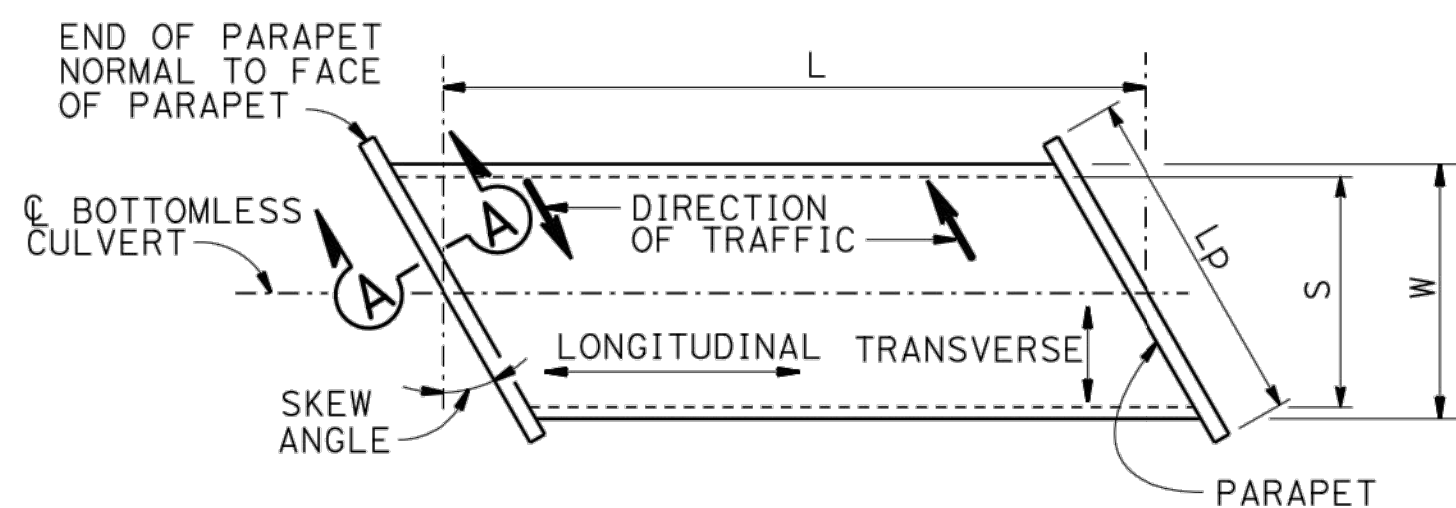

BOTTOMLESS CULVERT TERMINOLOGY

W = Width, L = Length, Lp = Parapet Length, S = Span

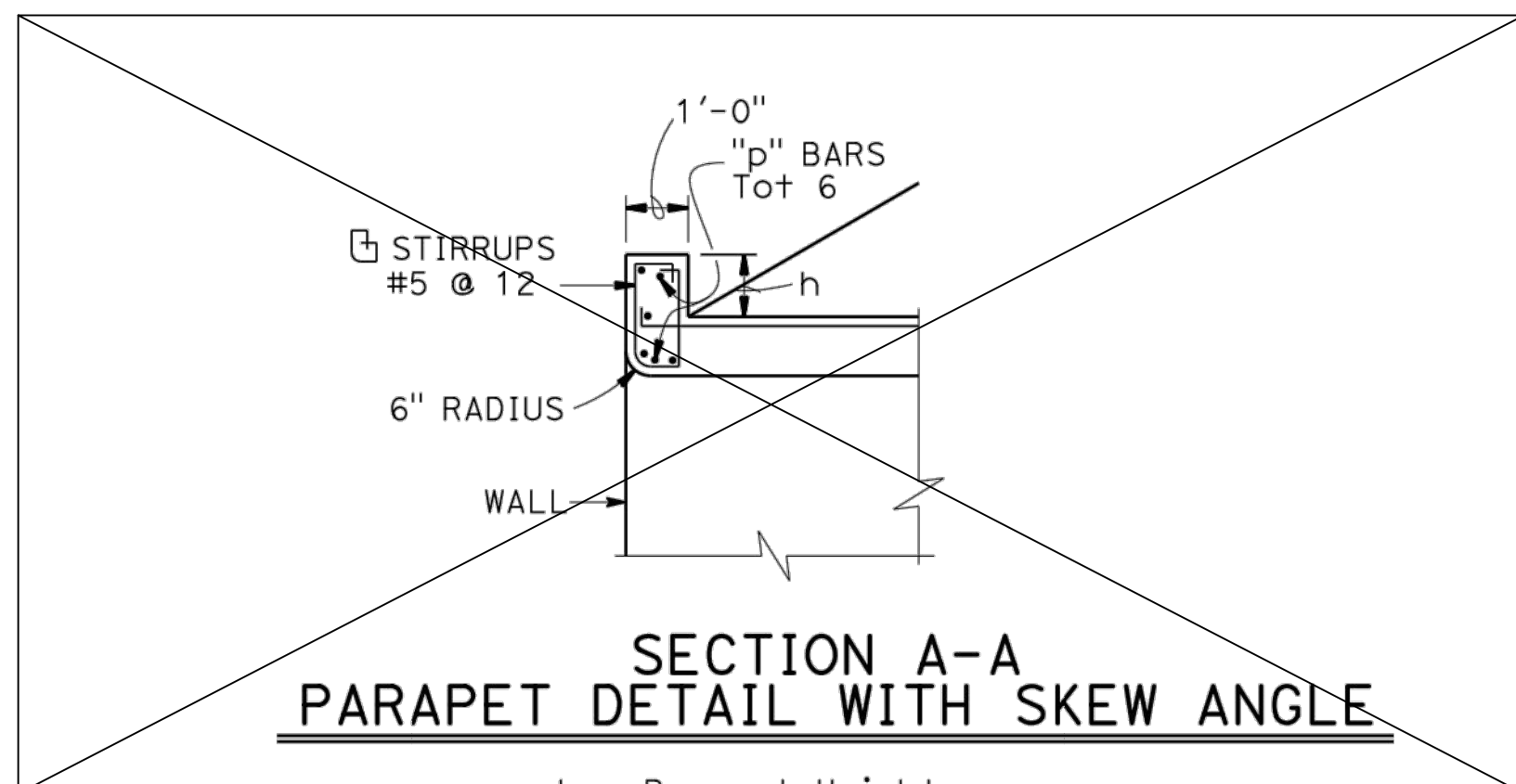

SECTION A-A PARAPET DETAIL WITH SKEW ANGLE

h = Parapet Height

SPAN, S	PARAPET "p" BARS & HEIGHT "h"					
	0° TO 15°		16° TO 30°		31° TO 45°	
	p	h	p	h	p	h
12'	#6	1'-0"	#7	1'-2"	#8	1'-6"
14'	#7	1'-0"	#8	1'-4"	#9	1'-8"
16'	#8	1'-2"	#9	1'-6"	#10	2'-0"
18'	#9	1'-3"	#10	1'-9"	#10	2'-3"
20'	#10	1'-5"	#10	2'-0"	#10	2'-6"

PARAPET REINFORCEMENT

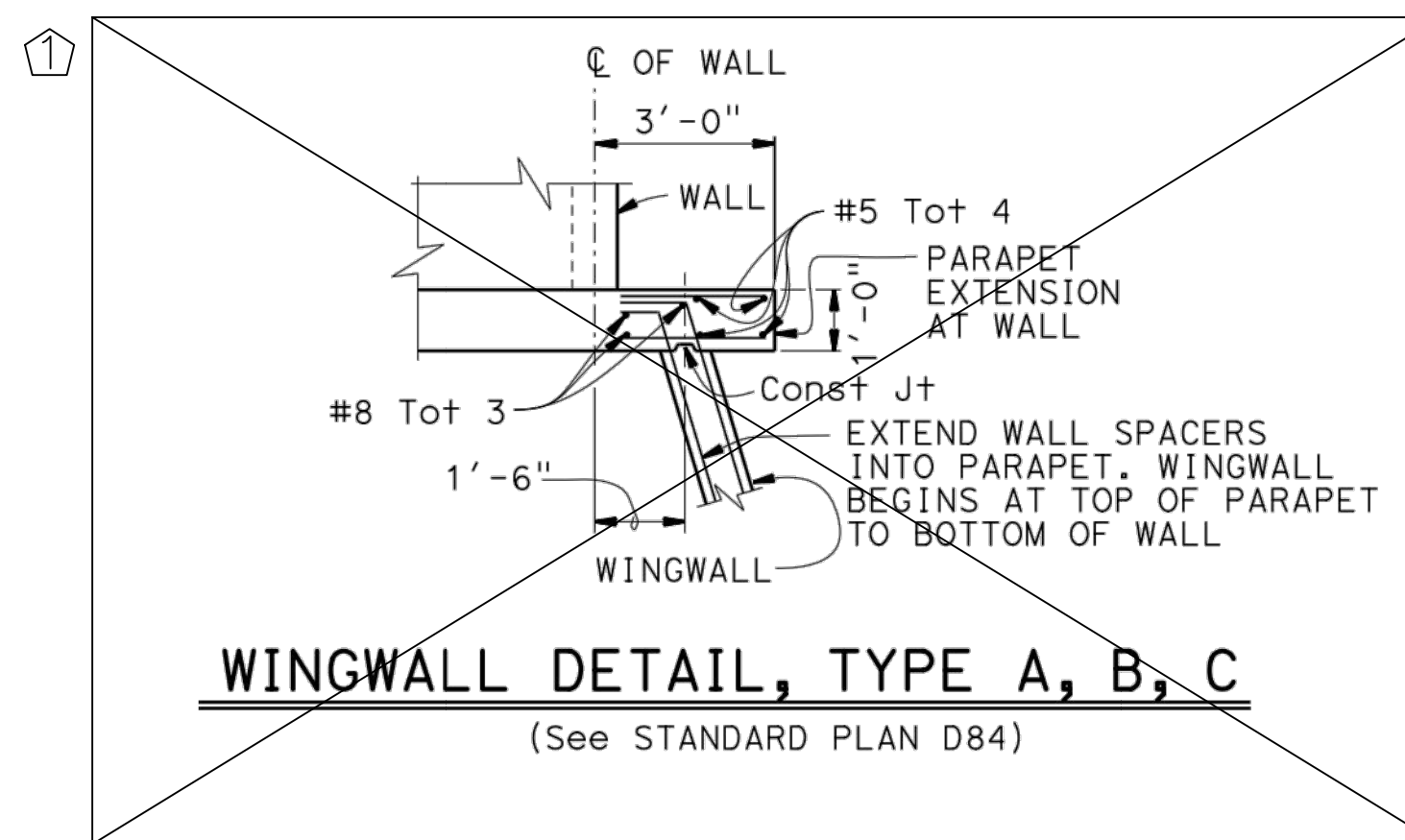

WINGWALL DETAIL, TYPE A, B, C

(See STANDARD PLAN D84)

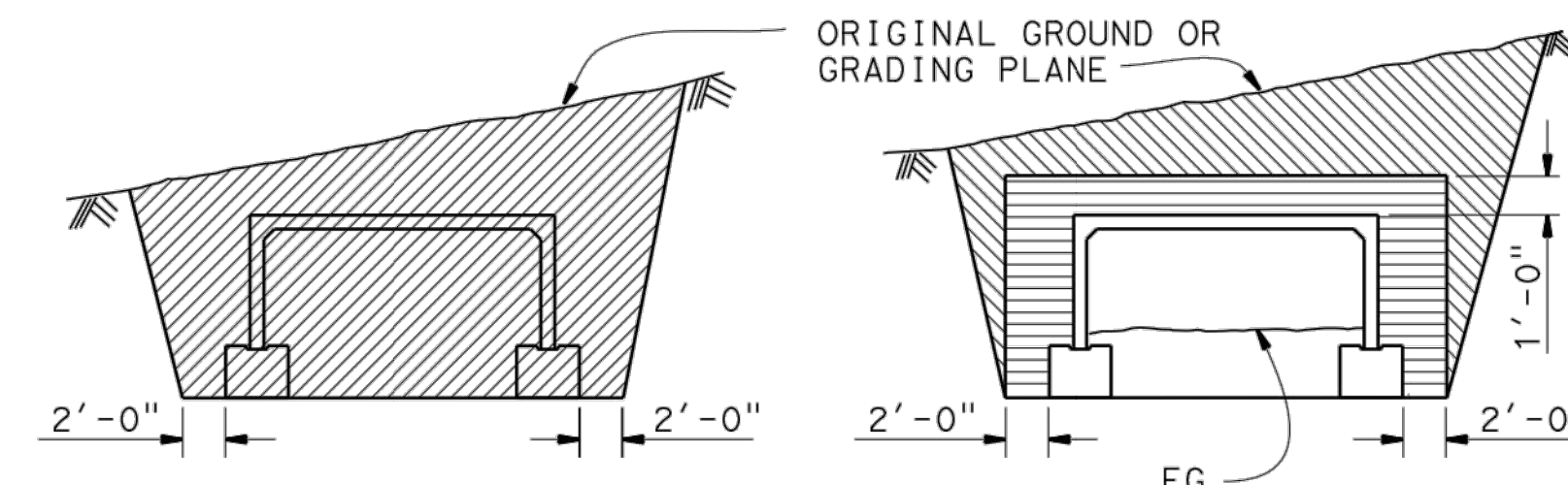

IN TRENCH

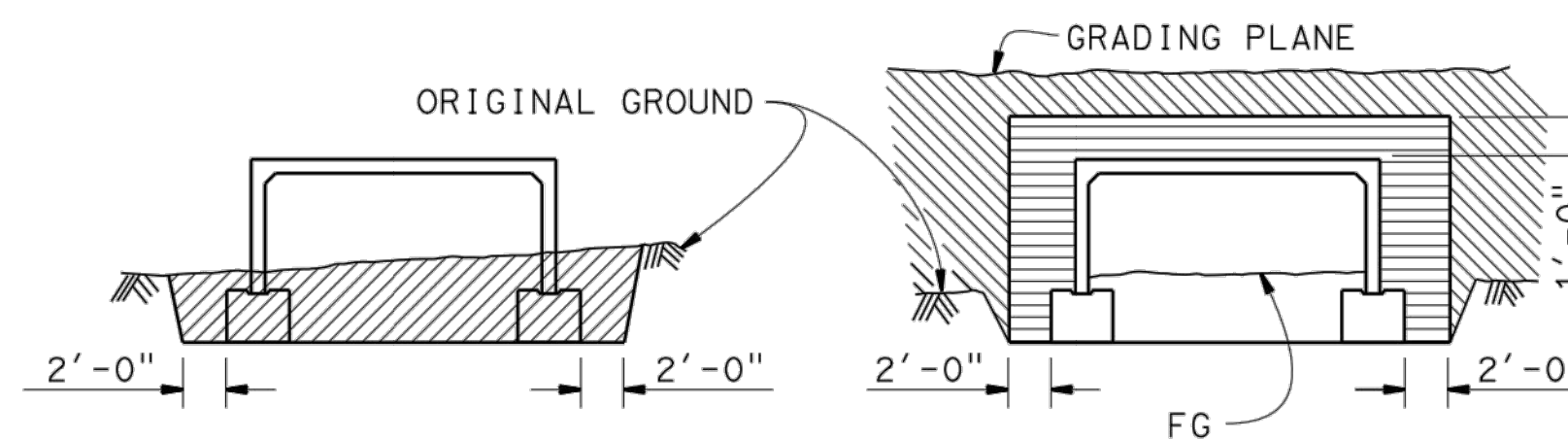

IN EMBANKMENT

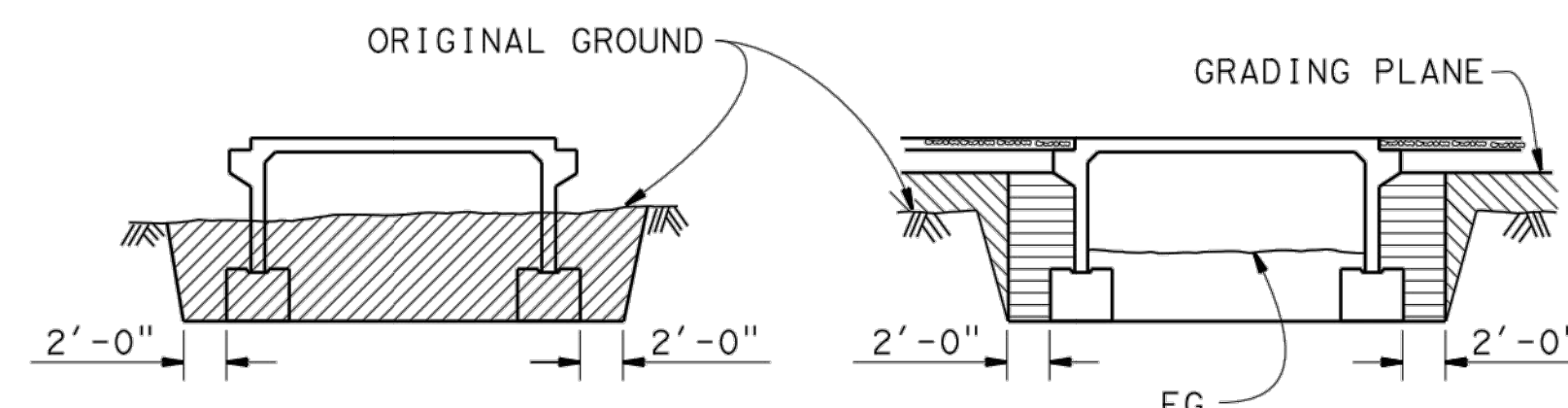

EXPOSED TOP



EXCAVATION



BACKFILL

LEGEND:

- STRUCTURE EXCAVATION (CULVERT)
- STRUCTURE BACKFILL (CULVERT)
- 95% RELATIVE COMPACTION
- ROADWAY EMBANKMENT
- ORIGINAL GROUND
- FINISH GRADE

BRIDGE STANDARD DETAILS		MODIFICATIONS SHOWN: DETAIL NOT USED		STATE OF CALIFORNIA DEPARTMENT OF TRANSPORTATION		DIVISION OF ENGINEERING SERVICES		CIP BOTTOMLESS CULVERT GENERAL CONFIGURATIONS	
xs17-050-1	May 2016	The components of the Bridge Standard Details have been prepared under the responsible charge of the Technical Owner, a registered civil engineer in the State of California.		BRIDGE NO.		POST MILE		CONTRACT NO.:	
FILE NO.	APPROVAL DATE			UNIT: PROJECT NUMBER & PHASE:		DISREGARD PRINTS BEARING EARLIER REVISION DATES		REVISION DATES	
Refer to: http://www.dot.ca.gov/hq/esc/techpubs/manual/bridgemanuals/bridge-standard-detail-sheets/index.html		FILE => xs17-050-1.dgn		ORIGINAL SCALE IN INCHES FOR REDUCED PLANS		TIME PLOTTED => 13:46		DATE PLOTTED => 12-JUL-2016	

DESIGNED_MAW	DATE 11/10/17	Scale AS SHOWN	CORNERSTONE structural engineering group	986 W Alluvial Ave - Suite 201 Fresno, California 93711 559.320.3200 fax 559.320.3201		PROJECT TRAVERS CREEK AT LINCOLN AVE COUNTY OF FRESNO, CA		DEPARTMENT OF PUBLIC WORKS & PLANNING BOTTOMLESS CULVERT GENERAL CONFIGURATIONS
DRAWN_TZE	DATE 11/10/17					Road No. 4721	Bridge No. 42C0683	Drawing No. S-8
CHECKED_JPJ	DATE 11/10/17							Sheet No. 26 of 40

DIST	COUNTY	ROUTE	POST MILES TOTAL PROJECT	SHEET No.	TOTAL SHEETS
REGISTERED CIVIL ENGINEER		DATE		REGISTERED PROFESSIONAL ENGINEER	
PLANS APPROVAL DATE				No. _____	
				Exp. _____	
				CIVIL	
The State of California or its officers or agents shall not be responsible for the accuracy or completeness of scanned copies of this plan sheet.					
The Registered Civil Engineer for the project is responsible for the selection and proper application of the component design and any modifications shown.					

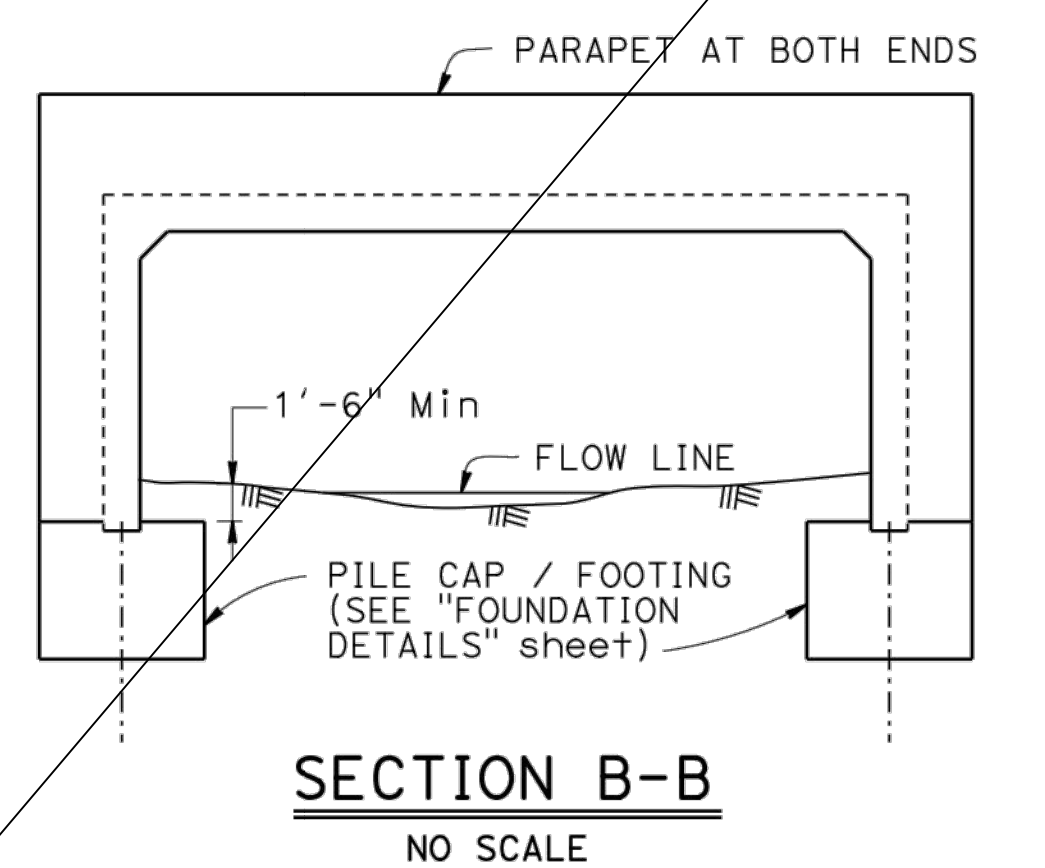
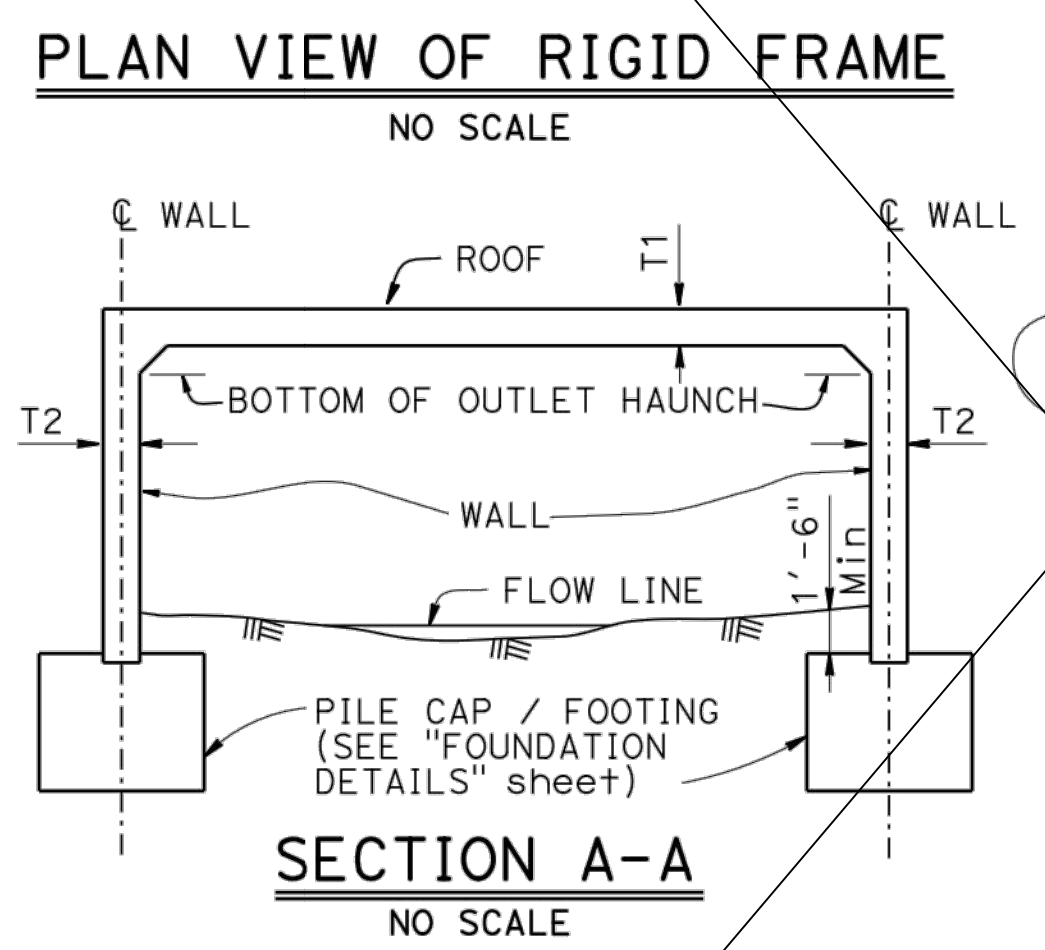
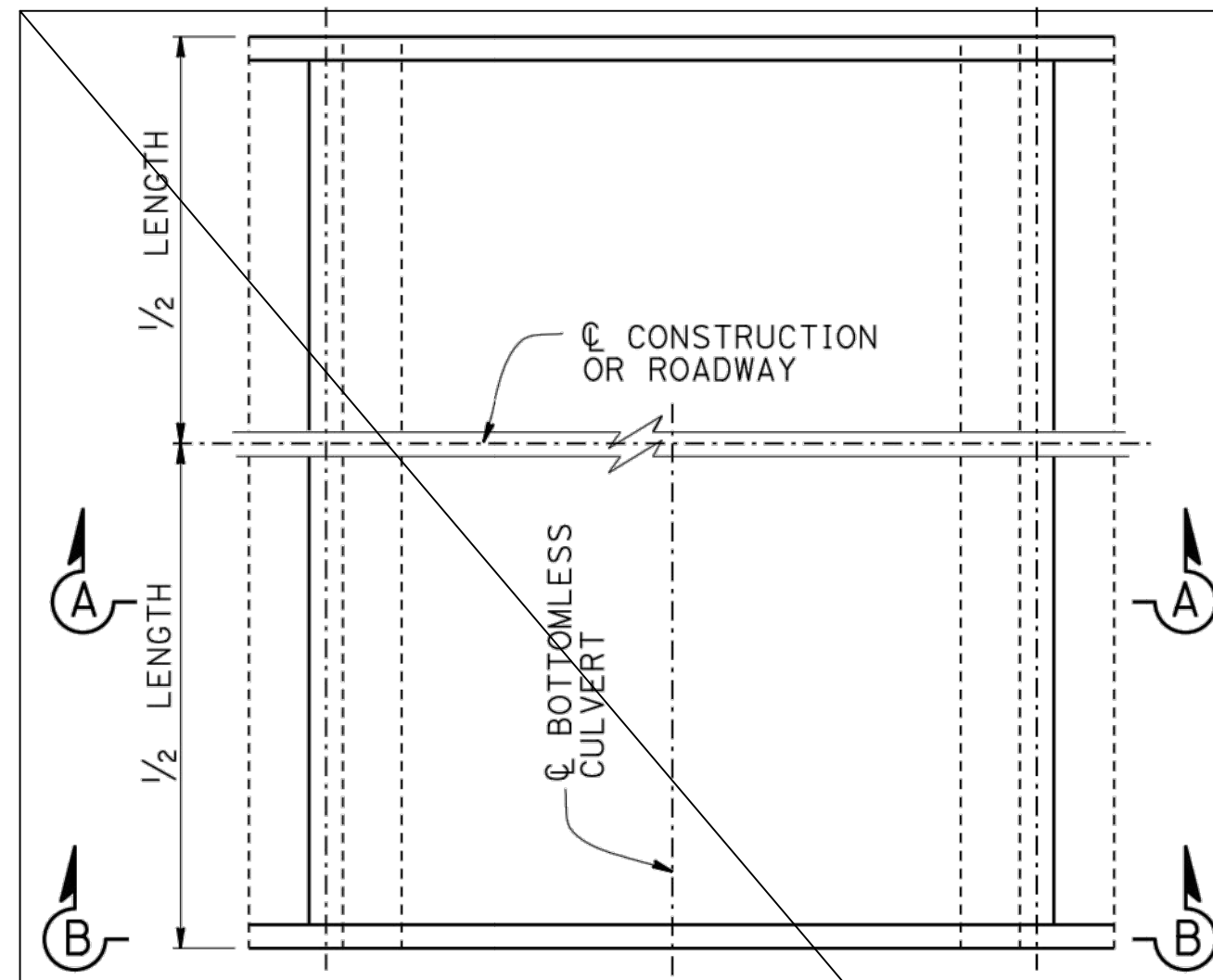

NOTE:
THE CONTRACTOR MUST VERIFY ALL CONTROLLING FIELD DIMENSIONS BEFORE ORDERING OR FABRICATING ANY MATERIAL.

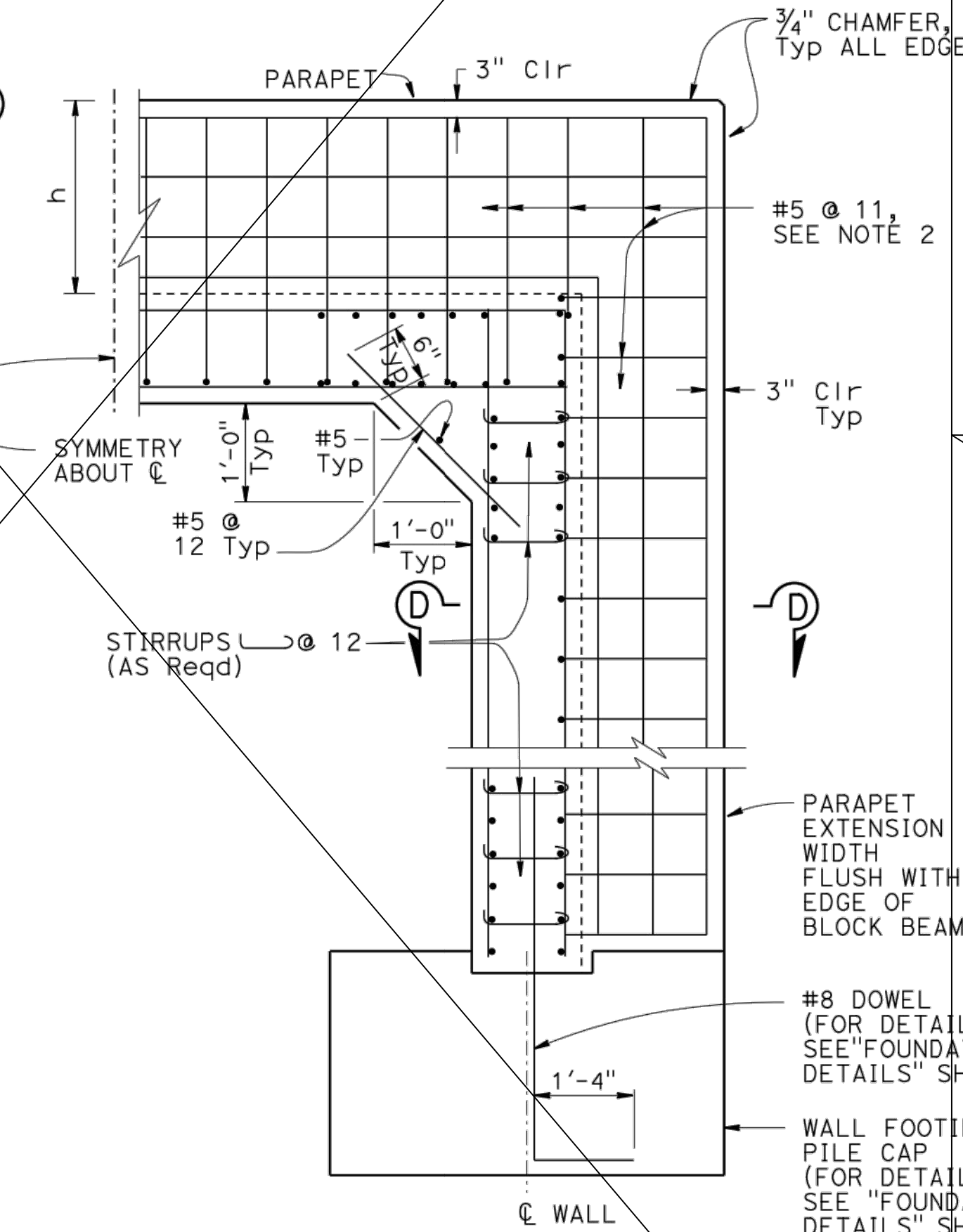
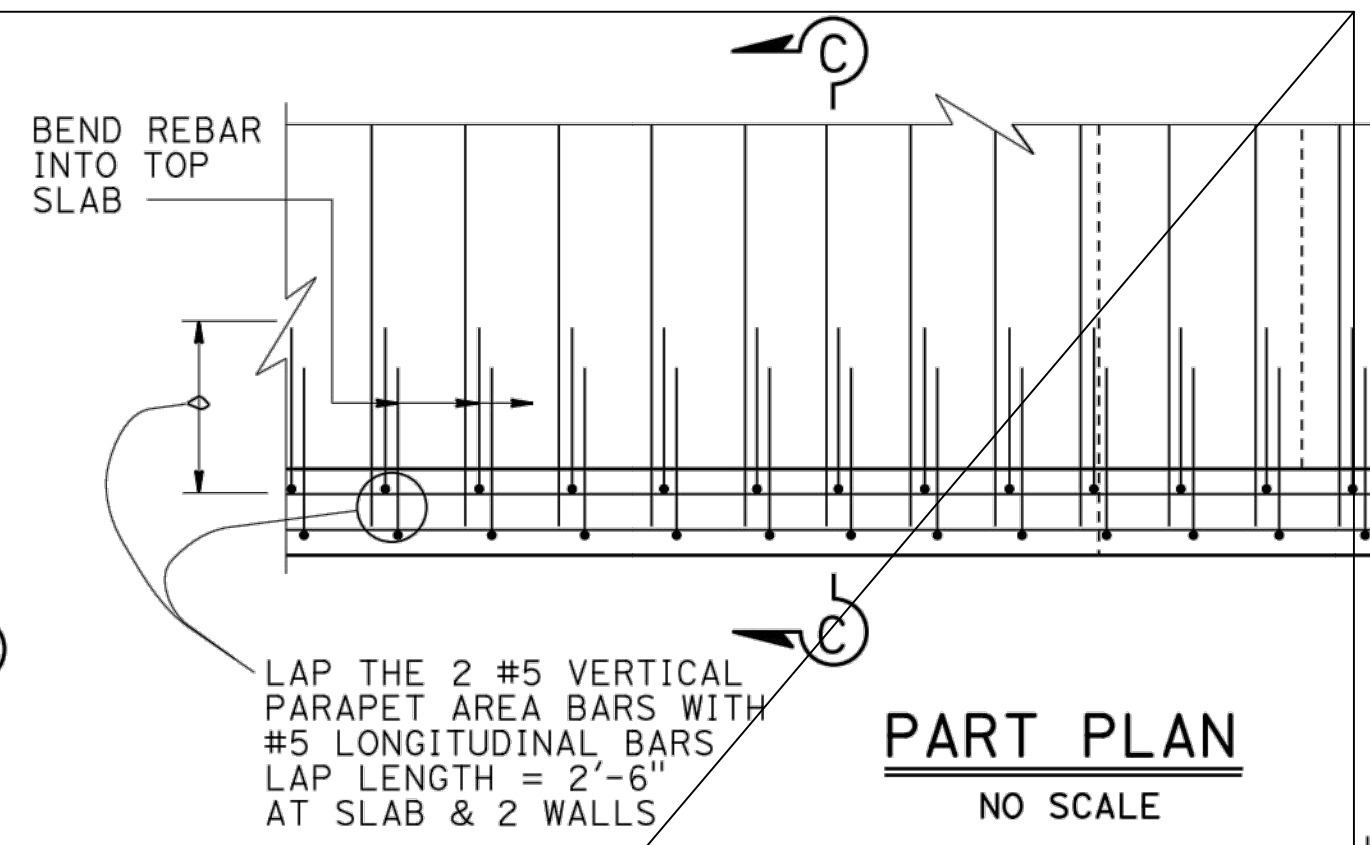

- NOTES:
- Refer to "GENERAL CONFIGURATIONS" sheet for required locations and parapet height, h.
 - Skewed parapets require additional reinforcement, see "GENERAL CONFIGURATIONS" sheet.

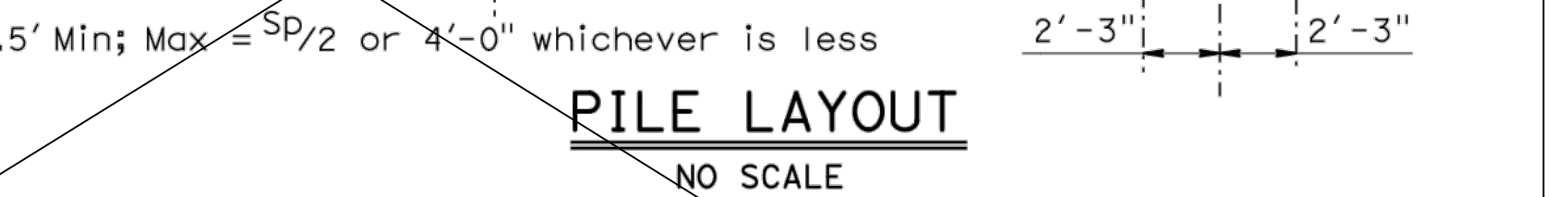
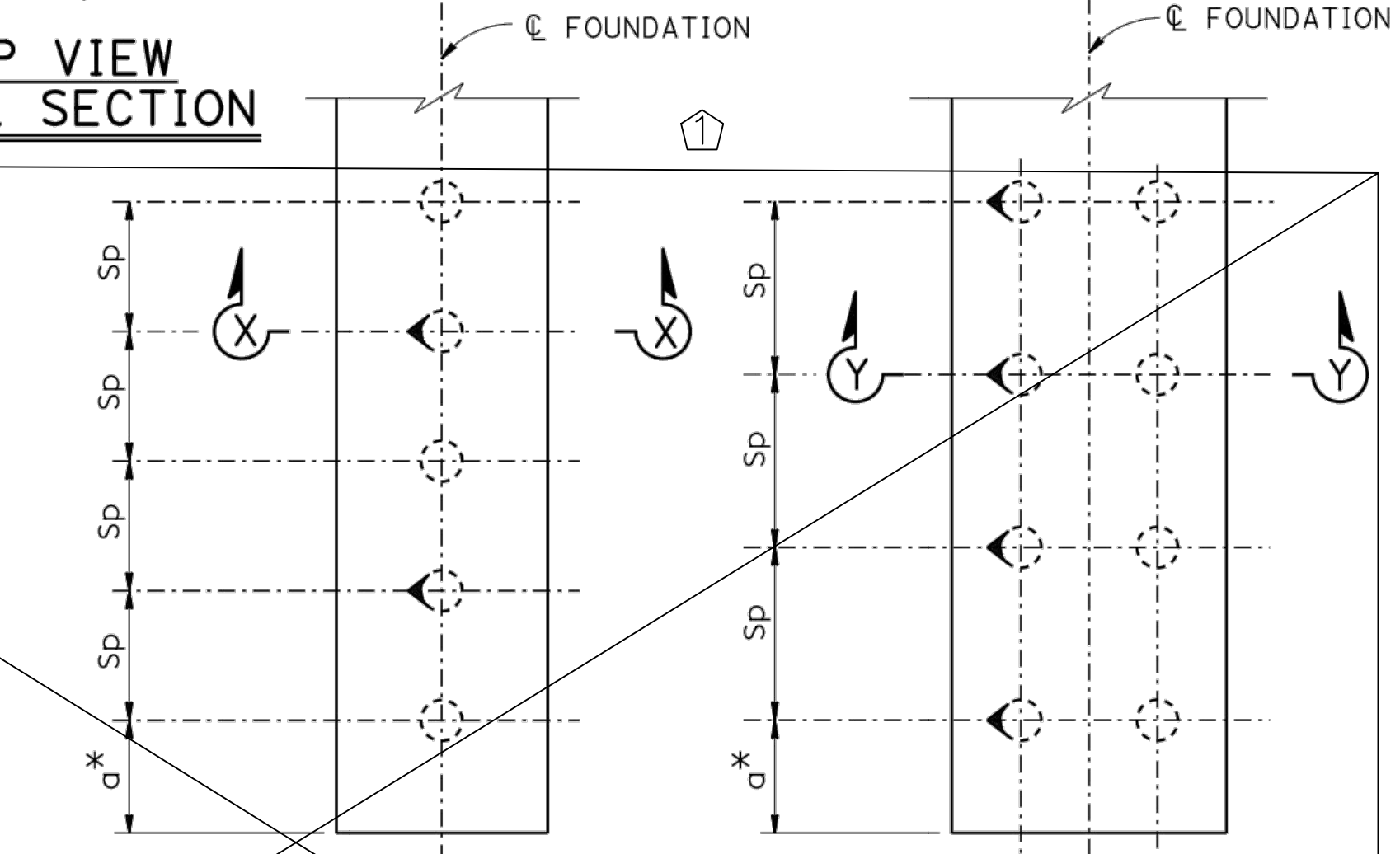
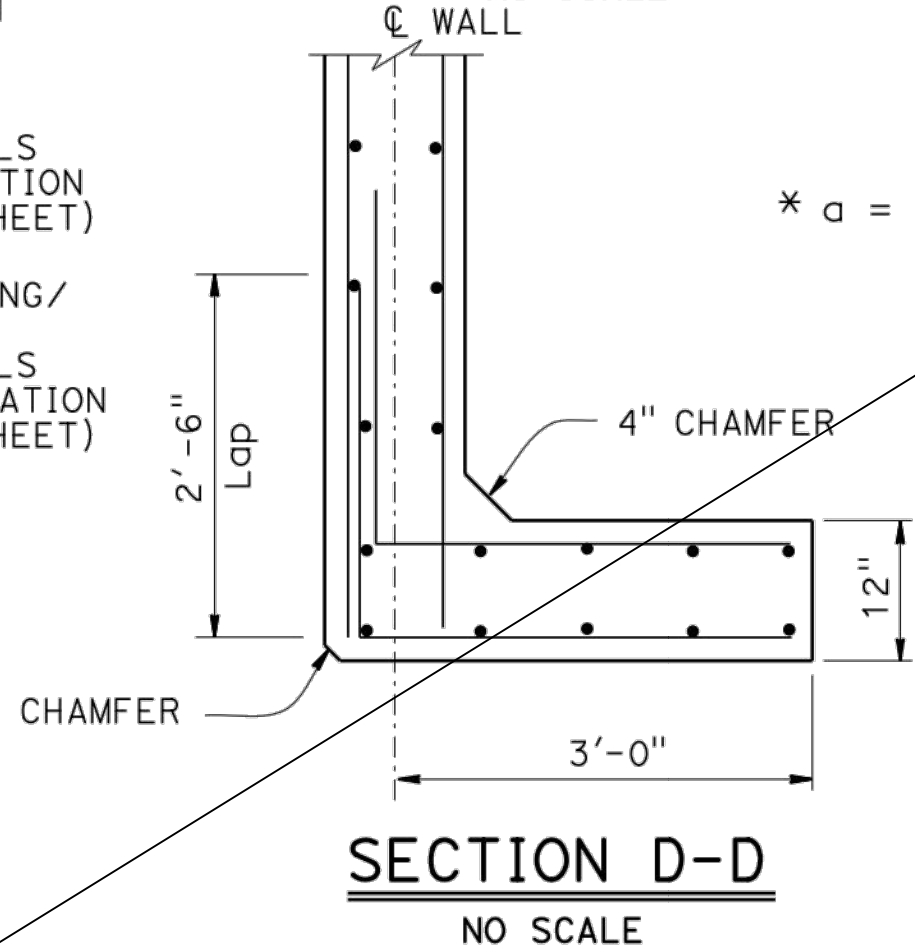
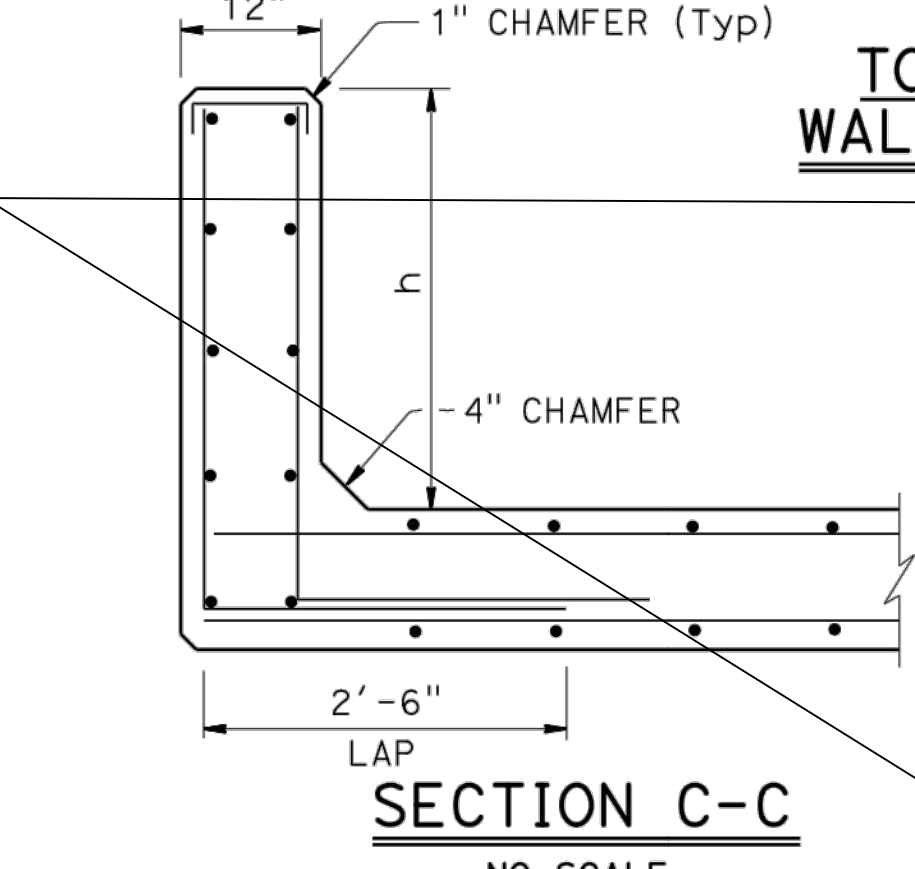
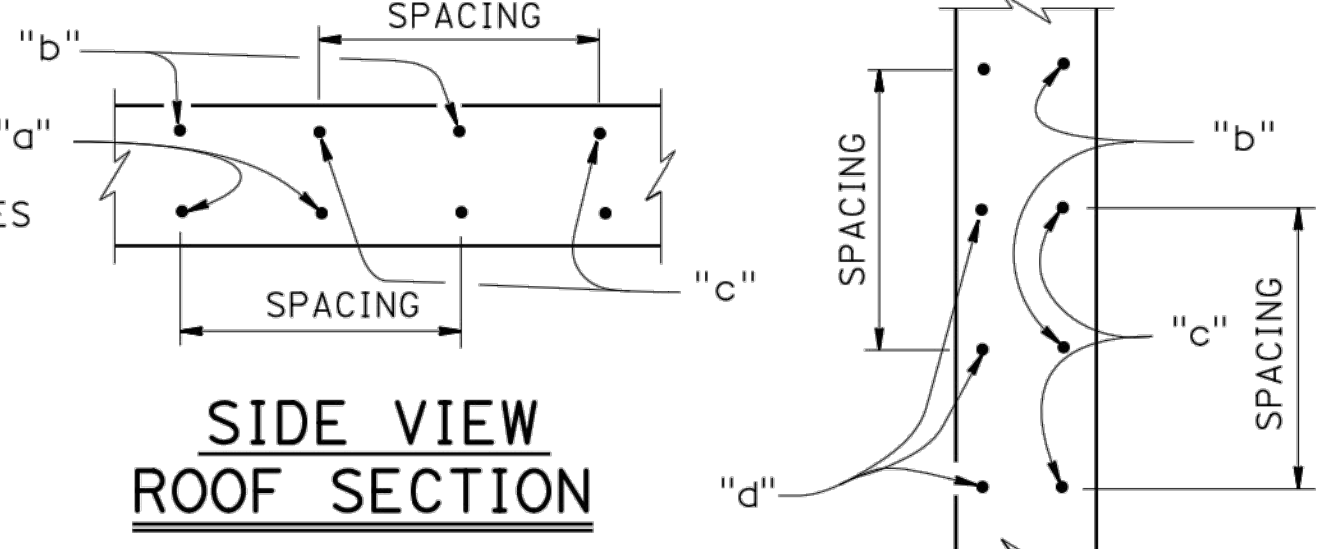
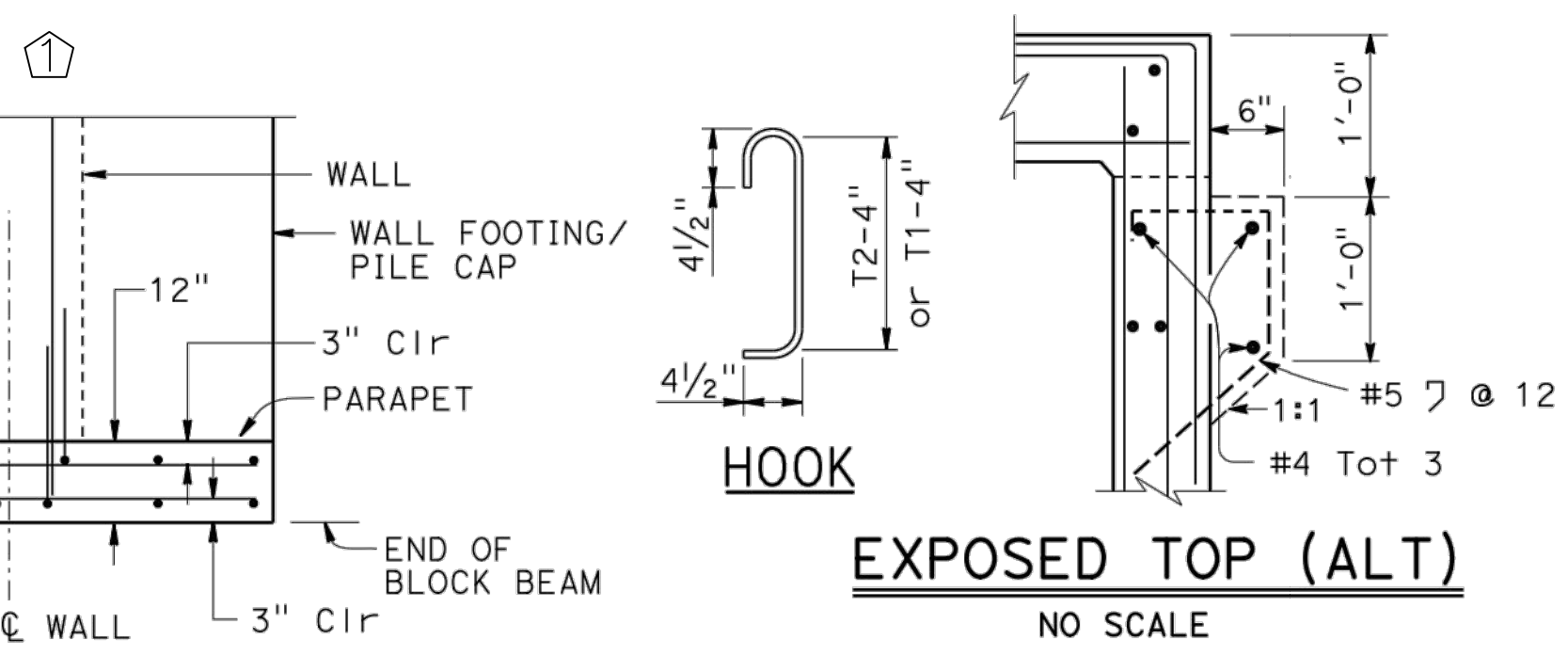

- FOUNDATION DESIGN NOTES:
- Stagger layout of piles in opposing footing to avoid conflict between battered piles.
 - Footings on rock: the bottom of footing shall follow the rock surface along the wall line, holes 1.5 inch in diameter and 2'-6" depth shall be drilled on 12 inch spacing along the centerline of footing into competent rock. Drill and bond No. 8 dowels in accordance with Standard Specifications Section 51.
 - Footing on soil: see "FOUNDATION DETAILS" sheet.
 - For Section X-X, Section Y-Y details, see "FOUNDATION DETAILS" sheet.

BRIDGE STANDARD DETAILS		MODIFICATIONS SHOWN:		STATE OF CALIFORNIA		DIVISION OF ENGINEERING SERVICES		BRIDGE NO.		CIP BOTTOMLESS CULVERT	
xs17-050-2	May 2016	DETAIL NOT USED		DEPARTMENT OF TRANSPORTATION				POST MILE		WALL, SLAB, & PILE DETAILS	
Refer to: http://www.dot.ca.gov/hq/esc/techpubs/manual/bridgemanuals/bridge-standard-detail-sheets/index.html		FILENAME => s136236		ORIGINAL SCALE IN INCHES FOR REDUCED PLANS		UNIT: PROJECT NUMBER & PHASE:		CONTRACT NO.:		DISREGARD PRINTS BEARING EARLIER REVISION DATES	
		TIME PLOTTED => 13:46		DATE PLOTTED => 12-JUL-2016				REVISION DATES		SHEET OF	

DESIGNED_MAW	DATE 11/10/17
DRAWN_TZE	DATE 11/10/17
CHECKED_JPU	DATE 11/10/17

Scale	AS SHOWN
-------	----------

CORNERSTONE
structural engineering group
986 W Alluvial Ave - Suite 201
Fresno, California 93711
559.320.3200
fax 559.320.3201

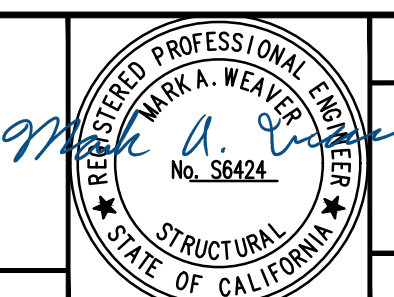

PROJECT
TRAVERS CREEK AT LINCOLN AVE
COUNTY OF FRESNO, CA
Road No. 4721 Bridge No. 42C0683

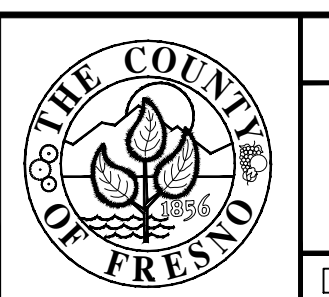

DEPARTMENT OF PUBLIC WORKS & PLANNING
CIP BOTTOMLESS CULVERT
WALL, SLAB, & PILE DETAILS
Drawing No. S-9 Sheet No. 27 of 40

CULVERTS WITH FOOTINGS ON SOIL

SPAN, S	12'										14'										16'									
	6'	8'	10'	12'	14'	15'	6'	8'	10'	12'	14'	15'	6'	8'	10'	12'	14'	15'												
WALL HEIGHT, H	6'	8'	10'	12'	14'	15'	6'	8'	10'	12'	14'	15'	6'	8'	10'	12'	14'	15'												
Max Earth Cover	10'	20'	10'	20'	10'	20'	10'	20'	10'	20'	10'	20'	10'	20'	10'	20'	10'	20'												
Depth - X	1'-9"	2'-0"	1'-9"	2'-0"	1'-9"	2'-0"	1'-9"	2'-0"	1'-9"	2'-0"	1'-9"	2'-0"	1'-9"	2'-0"	1'-9"	2'-0"	1'-9"	2'-0"												
Width - Y	5'-0"	6'-0"	5'-0"	6'-0"	5'-0"	6'-0"	5'-0"	6'-0"	5'-0"	6'-0"	5'-0"	6'-0"	5'-0"	6'-0"	5'-0"	6'-0"	5'-0"	6'-0"												
"f" Bar size	#6	#6	#6	#6	#6	#6	#6	#6	#6	#6	#6	#6	#6	#6	#6	#6	#6	#6												
Bar Spacing	12"	12"	12"	12"	12"	12"	12"	12"	12"	12"	12"	12"	12"	12"	12"	12"	12"	12"												
* Soil Pressure, q_u (ksf)	5.17	7.93	5.39	8.17	5.84	8.53	6.35	9.03	7.05	9.75	7.43	10.11	5.76	10.37	6.57	10.75	7.04	9.79												
Effective Footing Width, B' (ft)	3.47	4.20	3.45	4.18	3.43	4.17	3.42	4.17	3.41	4.17	3.41	4.17	3.48	3.71	3.20	3.69	3.19	4.17												

SPAN, S	18'										20'									
	6'	8'	10'	12'	14'	15' <th>6'</th> <th>8'</th> <th>10'</th> <th>12'</th> <th>14'</th> <th>15' </th>	6'	8'	10'	12'	14'	15'								
WALL HEIGHT, H	6'	8'	10'	12'	14'	15'	6'	8'	10'	12'	14'	15'								
Max Earth Cover	10'	20'	10'	20'	10'	20'	10'	20'	10'	20'	10'	20'								
Depth - X	2'-0"	2'-6"	2'-0"	2'-6"	2'-0"	2'-6"	2'-0"	2'-6"	2'-0"	2'-6"	2'-0"	2'-6"								
Width - Y	5'-6"	7'-6"	5'-6"	7'-6"	5'-6"	7'-6"	8'-0"	5'-6"	8'-0"	5'-6"	8'-0"	5'-6"								
"f" Bar size	#6	#7	#6	#7	#5	#7	#5	#7	#5	#7	#5	#7								
Bar Spacing	12"	12"	12"	12"	12"	12"	12"	12"	12"	12"	12"	12"								
* Soil Pressure, q_u (ksf)	6.77	9.34	6.96	9.49	7.40	9.84	7.88	9.30	8.59	9.98	8.97	10.20								
Effective Footing Width, B' (ft)	3.76	5.27	3.74	5.25	3.72	5.24	3.71	5.73	3.70	5.73	3.70	5.72								

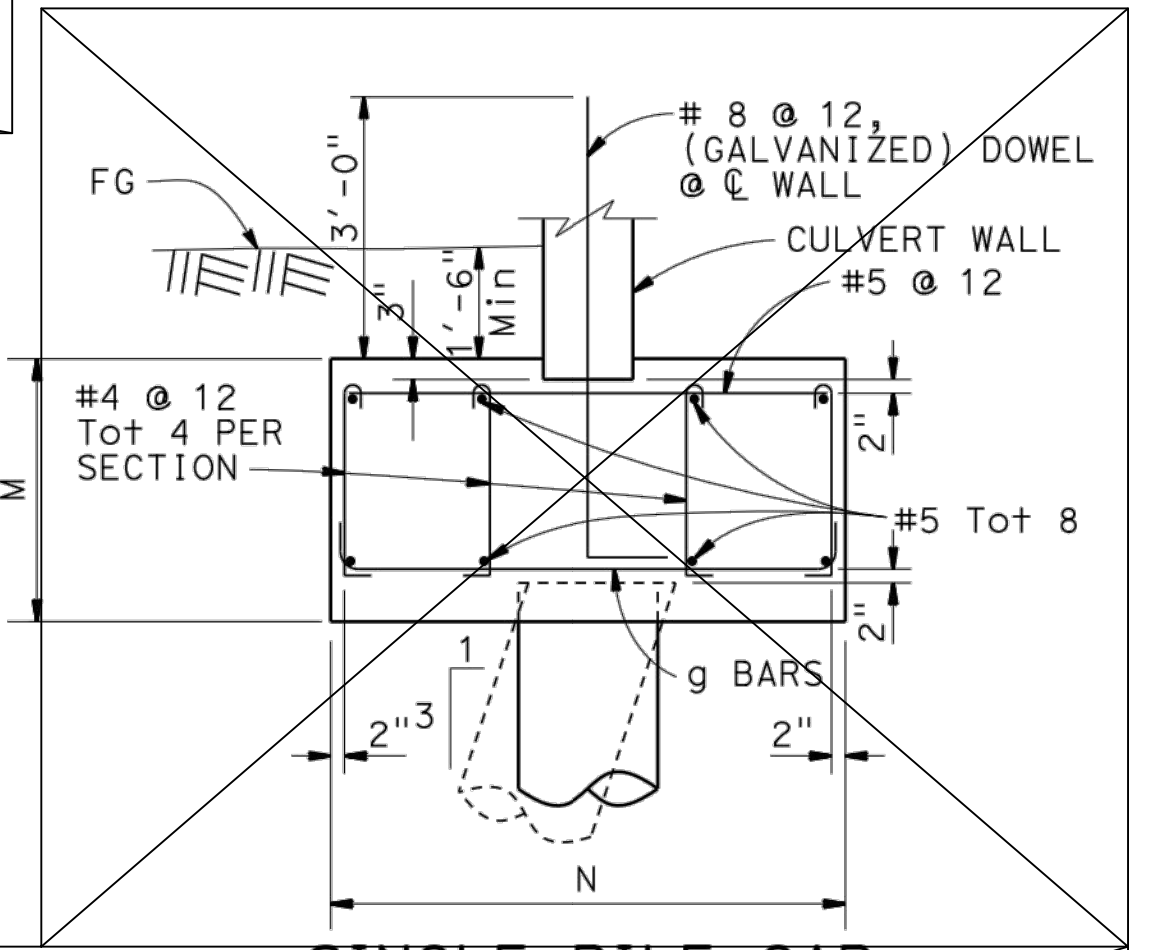
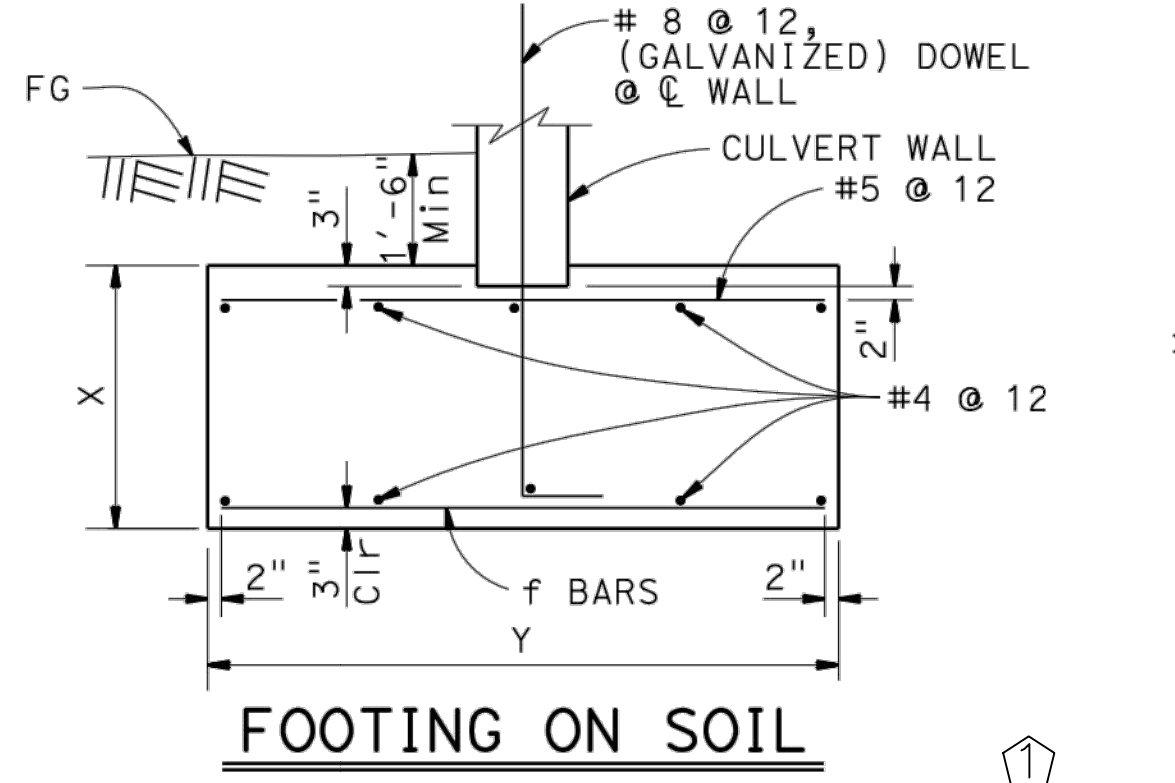

CULVERTS WITH PILE FOUNDATION OR WITH FOOTINGS ON ROCK

SPAN, S	12'										14'										16'									
	6'	8'	10'	12'	14'	15' <th>6'</th> <th>8'</th> <th>10'</th> <th>12'</th> <th>14'</th> <th>15' <th>6'</th><th>8'</th><th>10'</th><th>12'</th><th>14'</th><th>15' </th></th>	6'	8'	10'	12'	14'	15' <th>6'</th> <th>8'</th> <th>10'</th> <th>12'</th> <th>14'</th> <th>15' </th>	6'	8'	10'	12'	14'	15'												
WALL HEIGHT, H	6'	8'	10'	12'	14'	15'	6'	8'	10'	12'	14'	15'	6'	8'	10'	12'	14'	15'												
Max Earth Cover	10'	20'	10'	20'	10'	20'	10'	20'	10'	20'	10'	20'	10'	20'	10'	20'	10'	20'												
Number of Rows	1	2	1	2	2	2	2	2	2	2	2	2	1	2	1	2	2	2												
Pile Spacing	12'-0"	12'-0"	7'-3"	8'-9"	9'-9"	6'-3"	7'-6"	4'-9"	5'-9"	3'-9"	5'-3"	3'-6"	12'-0"	12'-0"	8'-0"	9'-9"	10'-3"	6'-6"												
Cap Depth - M	2'-6"	3'-0"	2'-6"	3'-0"	3'-0"	3'-0"	3'-0"	3'-0"	3'-0"	3'-0"	3'-0"	3'-0"	2'-6"	3'-0"	2'-6"	3'-0"	3'-0"	3'-0"												
Cap Width - N	3'-0"	7'-6"	3'-0"	7'-6"	7'-6"	6'-0"	7'-6"	7'-6"	7'-6"	7'-6"	7'-6"	7'-6"	3'-6"	7'-6"	3'-6"	7'-6"	7'-6"	7'-6"												
"g" Bar size	#6	#7	#6	#7	#7	#7	#7	#7	#7	#7	#7	#7	#6	#7	#6	#7	#6	#7												
Bar Spacing	12"	6"	12"	6"	6"	6"	6"	6"	6"	6"	6"	6"	12"	6"	12"	6"	6"	6"												

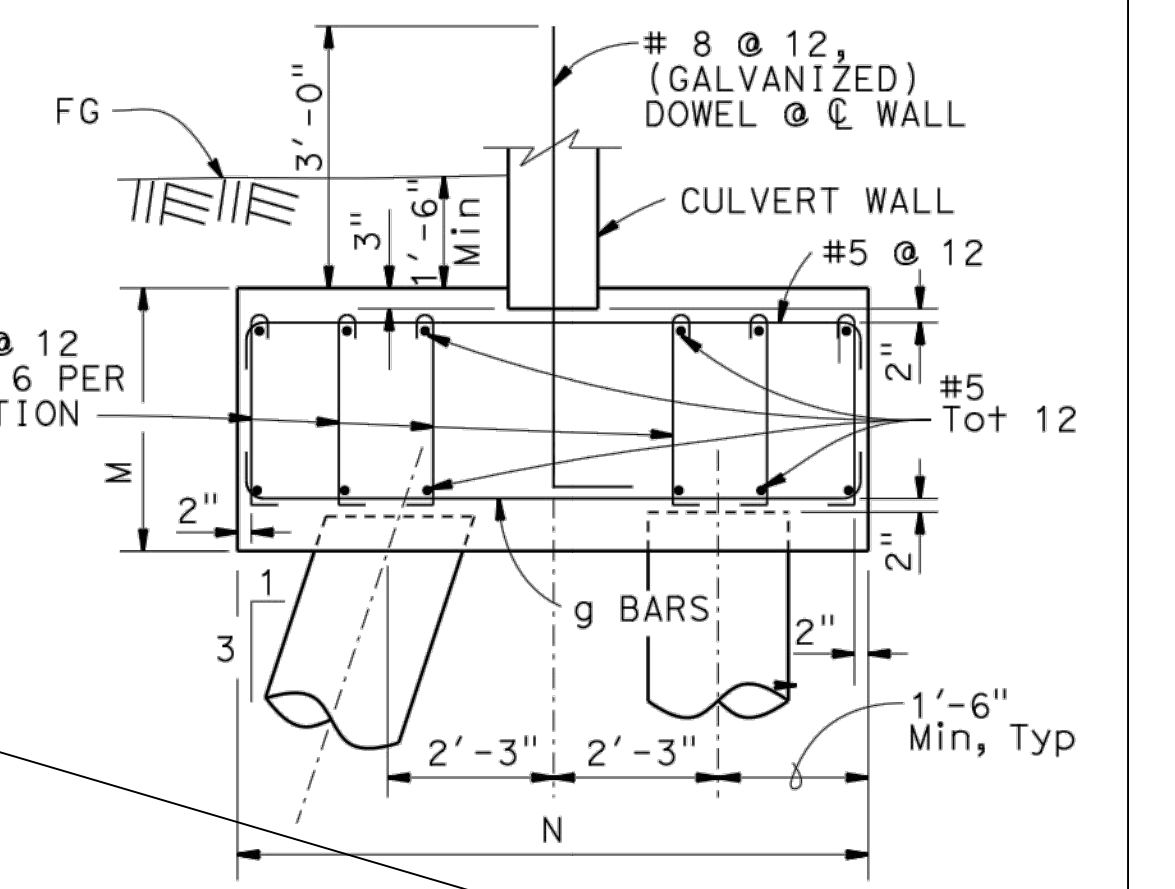

SPAN, S	18'										20'									
	6'	8'	10'	12'	14'	15' <th>6'</th> <th>8'</th> <th>10'</th> <th>12'</th> <th>14'</th> <th>15' </th>	6'	8'	10'	12'	14'	15'								
WALL HEIGHT, H	6'	8'	10'	12'	14'	15'	6'	8'	10'	12'	14'	15'								
Max Earth Cover	10'	20'	10'	20'	10'	20'	10'	20'	10'	20'	10'	20'								
Number of Rows	1	2	1	2	2	2	2	2	2	2	2	2								
Pile Spacing	10'-9"	11'-0"	8'-3"	11'-0"	10'-6"	7'-0"	7'-6"	5'-3"	6'-0"	4'-0"	5'-3"	3'-6"								
Cap Depth - M	3'-0"	3'-6"	3'-0"	3'-6"	3'-6"	3'-6"	3'-6"	3'-6"	3'-6"	3'-6"	3'-6"	3'-6"								
Cap Width - N	4'-0"	7'-6"	4'-0"	7'-6"	7'-6"	7'-6"	7'-6"	7'-6"	7'-6"	7'-6"	7'-6"	7'-6"								
"g" Bar size	#6	#6	#6	#7	#7	#7	#7	#7	#7	#7	#7	#7								
Bar Spacing	12"	6"	12"	6"	6"	6"	6"	6"	6"	6"	6"	6"								

NOTES:

- For pile layout, see "WALL, SLAB, & PILE DETAILS" sheet.
- Soil pressure shown in the table is equivalent uniform pressure per AASHTO LRFD.

BRIDGE STANDARD DETAILS		MODIFICATIONS SHOWN: DETAIL NOT USED		STATE OF CALIFORNIA DEPARTMENT OF TRANSPORTATION		DIVISION OF ENGINEERING SERVICES		CIP BOTTOMLESS CULVERT FOUNDATION DETAILS	
xs17-050-3 FILE NO.	May 2016 APPROVAL DATE	The components of the Bridge Standard Details have been prepared under the responsible charge of the Technical Owner, a registered civil engineer in the State of California.		BRIDGE NO.		POST MILE		CONTRACT NO.:	
Refer to: http://www.dot.ca.gov/hq/esc/techpubs/manual/bridgemanuals/bridge-standard-detail-sheets/index.html				FILE => xs17-050-3.dgn USERNAME => s136236		TIME PLOTTED => 13:46		DATE PLOTTED => 12-JUL-2016	
ORIGINAL SCALE IN INCHES FOR REDUCED PLANS				UNIT: PROJECT NUMBER & PHASE:		DISREGARD PRINTS BEARING EARLIER REVISION DATES		REVISION DATES	

DESIGNED_MAW	DATE 11/10/17		986 W Alluvial Ave - Suite 201 Fresno, California 93711 559.320.3200 fax 559.320.3201		PROJECT			DEPARTMENT OF PUBLIC WORKS & PLANNING	
DRAWN_TZE	DATE 11/10/17				TRAVERS CREEK AT LINCOLN AVE			CIP BOTTOMLESS CULVERT FOUNDATION DETAILS	
CHECKED_JPU	DATE 11/10/17				Road No. 4721			Drawing No. S-10	
REVISION	AS SHOWN	FOR R/W DATA AND ACCURATE ACCESS DETERMINATION SEE R/W RECORDS AT PUBLIC WORKS		Bridge No. 42C0683		Sheet No. 28 of 40			

GENERAL NOTES

- 1. RAP NOT TO BE USED FOR BACKFILL NEAR WATERWAY.

ABBREVIATIONS

AB	AGGREGATE BASE
AC	ASPHALT CONCRETE
AP	ANGLE POINT
BEG	BEGIN
DWY	DRIVEWAY
(E)	EXISTING
EP	EDGE OF PAVEMENT
ETW	EDGE OF TRAVEL WAY
HMA	HOT MIX ASPHALT
HP	HINGE POINT
Lt	LEFT
OG	ORIGINAL GROUND
OH	OVERHEAD
PG	PROFILE GRADE
PG&E	PACIFIC GAS AND ELECTRIC
PROP	PROPOSED
RAP	RECLAIMED ASPHALT PAVEMENT
R/W	RIGHT OF WAY
Rt	RIGHT
SAW	SAWCUT
TYP	TYPICAL
UG	UNDERGROUND
VAR	VARIABLES
WSE	WATER SURFACE ELEVATION

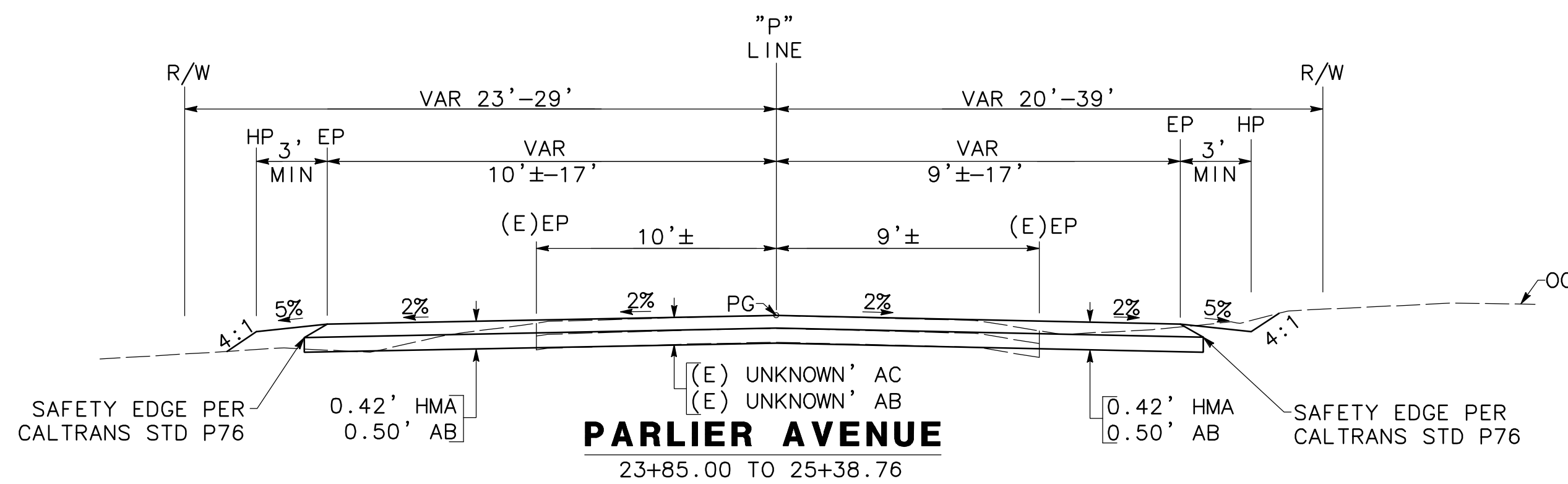
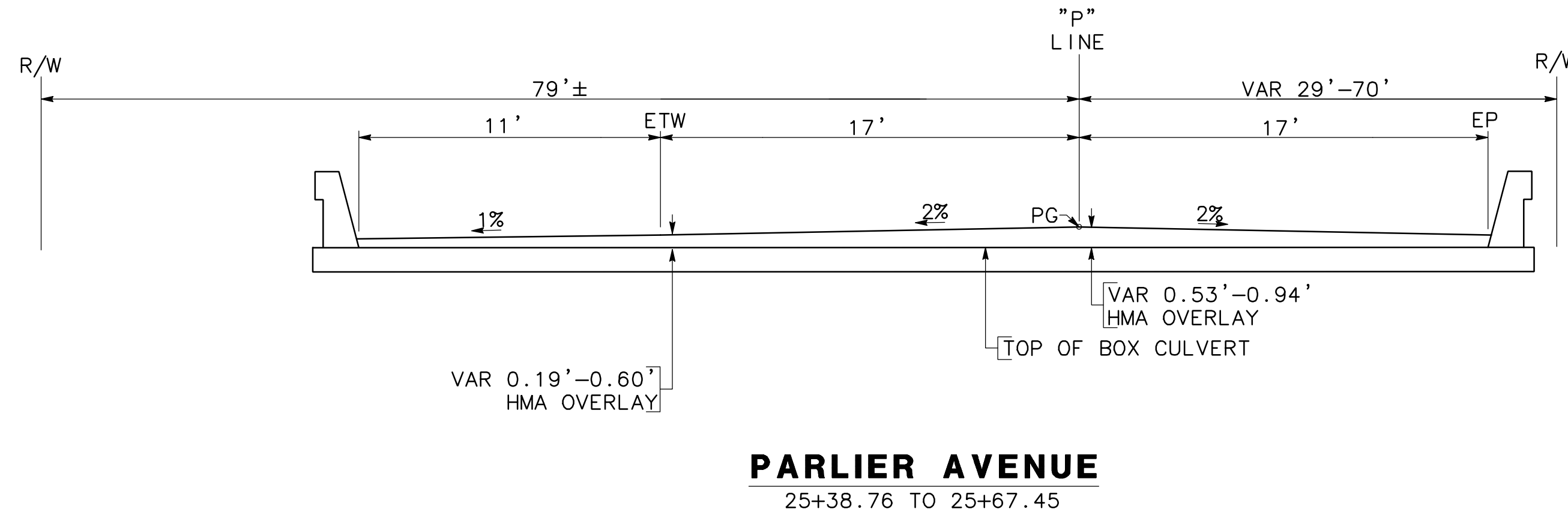
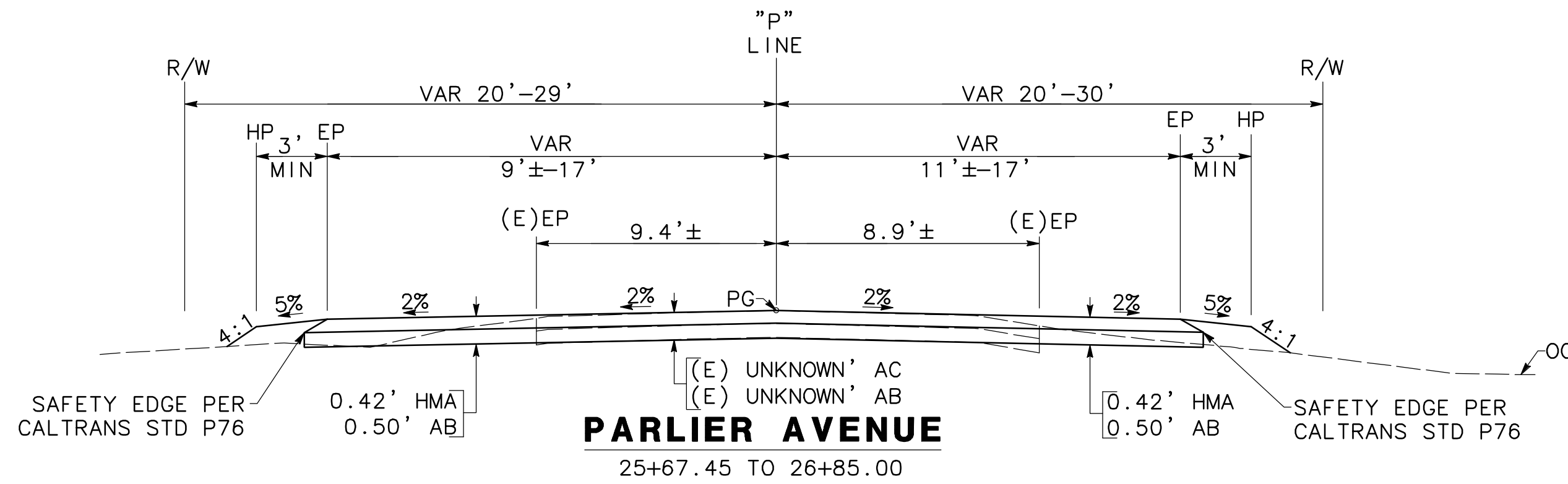

	DATE	RECORD DRAWING	SCALE		PROJECT	DEPARTMENT OF PUBLIC WORKS AND PLANNING
DESIGNED: CL	04/14/2023	RESIDENT ENGINEER			TRAVERS CREEK AT PARLIER AVE	TRAVERS CREEK AT PARLIER AVE
DRAWN: DA	04/14/2023				COUNTY OF FRESNO, CA	TYPICAL SECTIONS
CHECKED: CH	04/14/2023			SUPERVISING ENGINEER	ROAD NO. 6263	DRAWING NO. X-3
FOR RIGHT OF WAY DATA AND ACCURATE ACCESS DETERMINATION, SEE DOCUMENTS IN THE DEPARTMENT OF PUBLIC WORKS AND PLANNING.				DATE	BRIDGE NO. 42C0684	SHEET NO. 30
					TOTAL 40	

GENERAL NOTES

1. CONTRACTORS SHALL COMPLY WITH BUSINESS AND PROFESSIONS CODE SECTION 8771(B) REGARDING REFERENCING, PRESERVING, AND RECONSTRUCTING MONUMENTS, WHETHER OR NOT MONUMENTS ARE SHOWN IN THESE PLANS.
2. CONTRACTOR SHALL PROVIDE THE ENGINEER A MINIMUM OF (2) WEEKS NOTICE PRIOR TO COMMENCING ANY WORK THAT COULD DAMAGE OR DESTROY ANY SURVEY MONUMENTS.
3. IF MONUMENT IS DAMAGED BY CONSTRUCTION OPERATIONS THE CONTRACTOR SHALL REPLACE AT THE CONTRACTORS COST.
4. CONTRACTOR IS ALSO RESPONSIBLE FOR PERMANENTLY STABILIZING ALL DISTURBED AREAS, INCLUDING LOCATIONS OUTSIDE OF WHAT IS DEPICTED IN THIS PLAN.

BASIS OF BEARINGS:

THE NORTH LINE OF THE SOUTHWEST QUARTER OF SECTION 19, TOWNSHIP 15 SOUTH, RANGE 24 EAST, MOUNTAIN DIABLO BASE AND MERIDIAN, BEAR S89°45'13"E PER PARCEL MAP 7330, RECORDED IN BOOK 51 OF PARCEL MAPS, AT PAGE 9, ON FILE WITH THE FRESNO COUNTY RECORDER.

BASIS OF VERTICAL CONTROL:

BENCHMARK LO 74, A FRESNO COUNTY BRASS CAP MONUMENT, LOCATED ON A CONCRETE WHEEL GUARD, 11.2' NORTH OF THE CENTERLINE OF PARLIER AVENUE, HAS AN NGVD29 ELEVATION OF 358.313 FEET PER FRESNO COUNTY BENCHMARK RECORDS.

LEGEND

- FRESNO COUNTY CONTROL POINTS



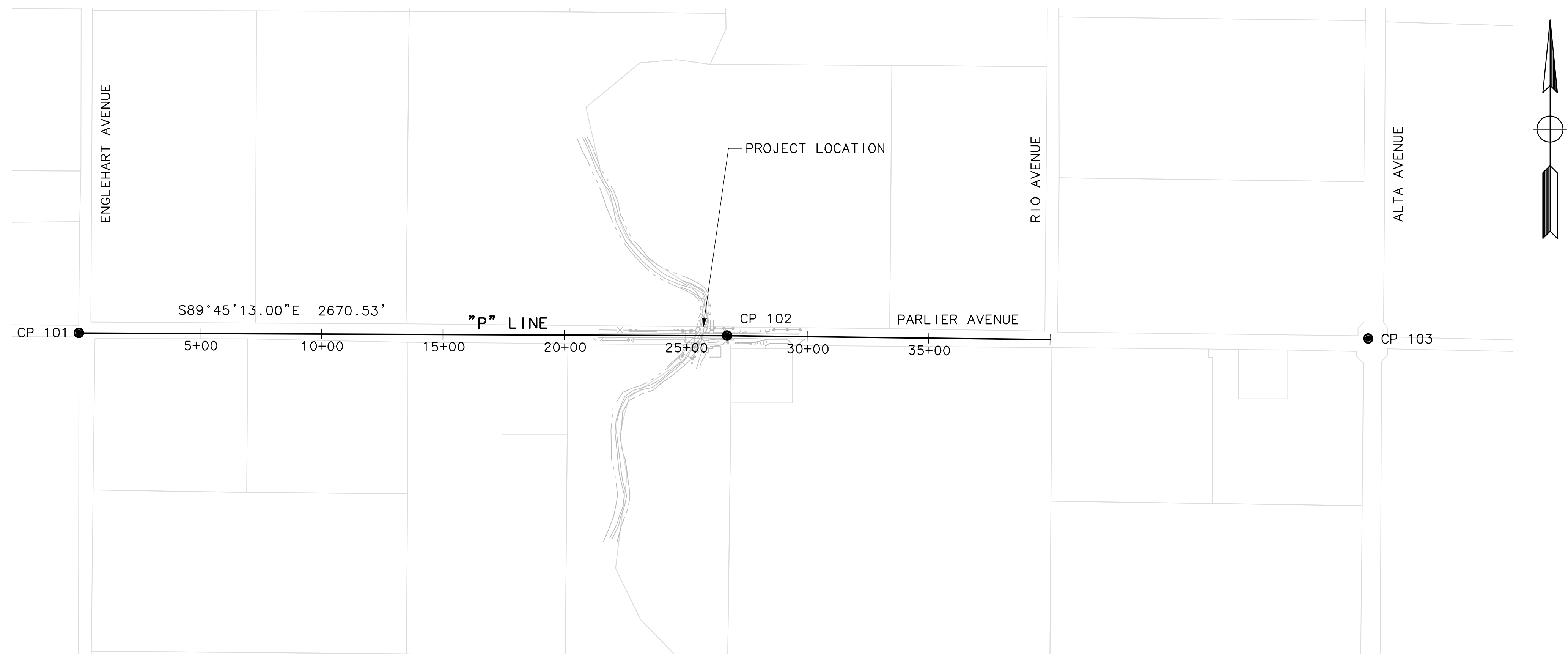

CONTROL FOR DESIGN & CONSTRUCTION

POINT	NORTHING	EASTING	ELEVATION	DESCRIPTION
101	10021.64	7329.56	357.24	Fd. 1" IP, Dn. 10"
102	10010.16	10000.06	359.77	Fd. 1" IP No, Tag, Dn. 10"
103	9998.85	12640.68	364.09	Fd. FCBCM, Dn. 6"

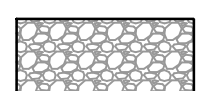
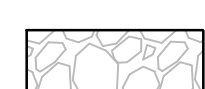

DESIGNED: CL	DATE: 04/14/2023	RECORD DRAWING	SCALE		PROJECT		DEPARTMENT OF PUBLIC WORKS AND PLANNING
DRAWN: DA	DATE: 04/14/2023	RESIDENT ENGINEER			TRAVERS CREEK AT PARLIER AVE		TRAVERS CREEK AT PARLIER AVE
CHECKED: CH	DATE: 04/14/2023				COUNTY OF FRESNO, CA		PROJECT CONTROL
FOR RIGHT OF WAY DATA AND ACCURATE ACCESS DETERMINATION, SEE DOCUMENTS IN THE DEPARTMENT OF PUBLIC WORKS AND PLANNING.				SUPERVISING ENGINEER	ROAD NO. 6263	BRIDGE NO. 42C0684	DRAWING NO. PC-3
				DATE			SHEET NO. 31
							TOTAL 40

LEGEND:

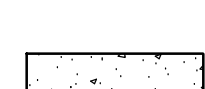
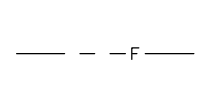
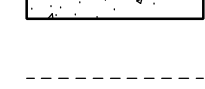
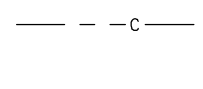
-  NEW PAVEMENT
-  AC PAVEMENT - DWY
-  REMOVE TREE
-  AB PAVEMENT - DWY
-  ROCK SLOPE PROTECTION
-  HMA OVERLAY
-  CONCRETE CHANNEL LINING
-  FILL
-  SAWCUT
-  CUT

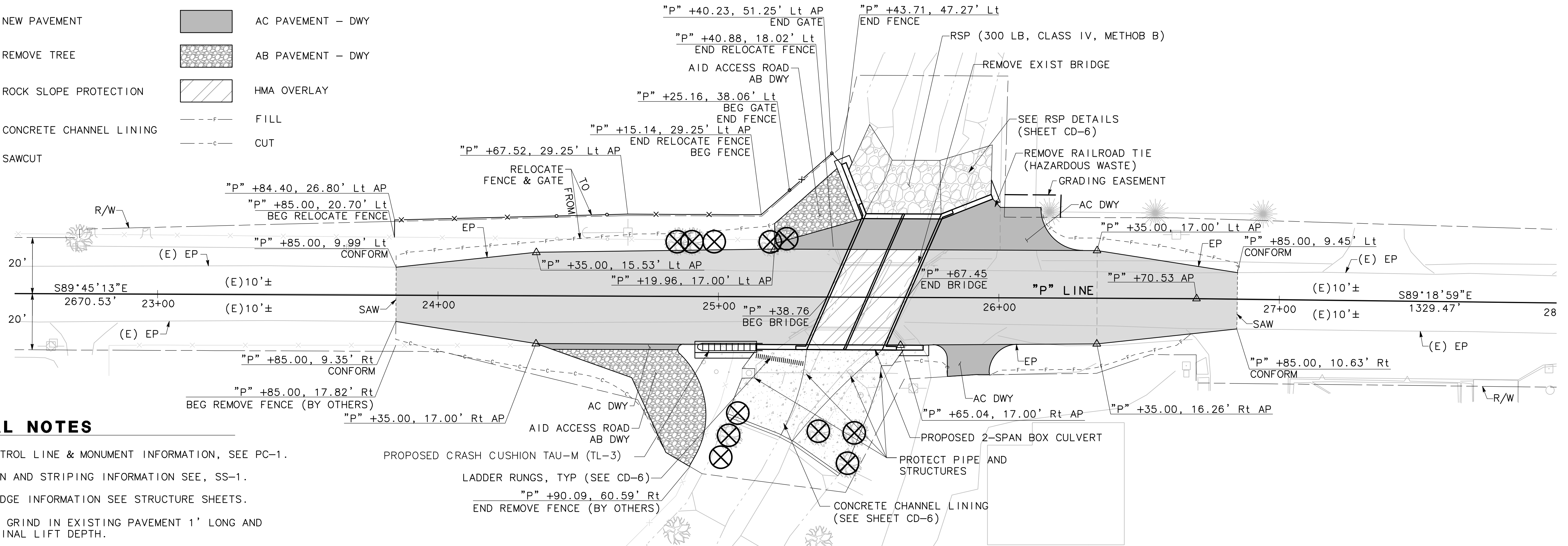



PARLIER AVENUE
SCALE: 1" = 20'

GENERAL NOTES

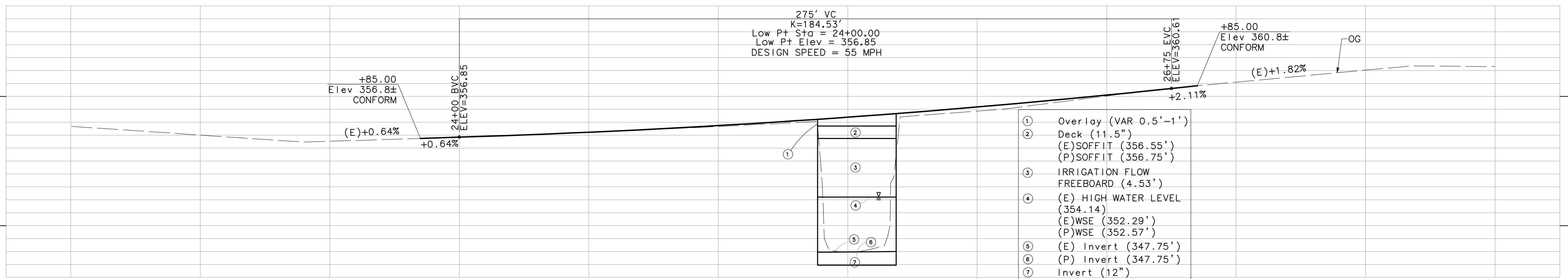
1. FOR CONTROL LINE & MONUMENT INFORMATION, SEE PC-1.
2. FOR SIGN AND STRIPING INFORMATION SEE, SS-1.
3. FOR BRIDGE INFORMATION SEE STRUCTURE SHEETS.
4. PROVIDE GRIND IN EXISTING PAVEMENT 1' LONG AND MATCH FINAL LIFT DEPTH.
5. CONCRETE SLOPE PAVING BEHIND WING WALL 2' WIDE TO TOP OF CHANNEL AND 6" MAX DEEP AS DIRECTED BY THE COUNTY ENGINEER.

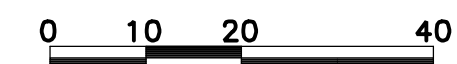

"P" LINE PROFILE
SCALE : H: 1"=20'
V: 1"=4'

	DATE	RECORD DRAWING	SCALE				
DESIGNED: CL	04/14/2023	RESIDENT ENGINEER	 SCALE: 1" = 20'	SUPERVISING ENGINEER	DATE		PROJECT
DRAWN: DA	04/14/2023			TRAVERS CREEK AT PARLIER AVE	COUNTY OF FRESNO, CA		DEPARTMENT OF PUBLIC WORKS AND PLANNING TRAVERS CREEK AT PARLIER AVE PLAN AND PROFILE
CHECKED: CH	04/14/2023			ROAD NO. 6263	BRIDGE NO. 42C0684	DRAWING NO. PP-3	SHEET NO. 32

FOR RIGHT OF WAY DATA AND ACCURATE ACCESS DETERMINATION, SEE DOCUMENTS IN THE DEPARTMENT OF PUBLIC WORKS AND PLANNING.

CURVE DATA

No. (X)	R	Δ	T	L
①	2.00'	135°00'00"	4.83'	4.71'
②	30.00'	76°14'38"	23.54'	39.92'

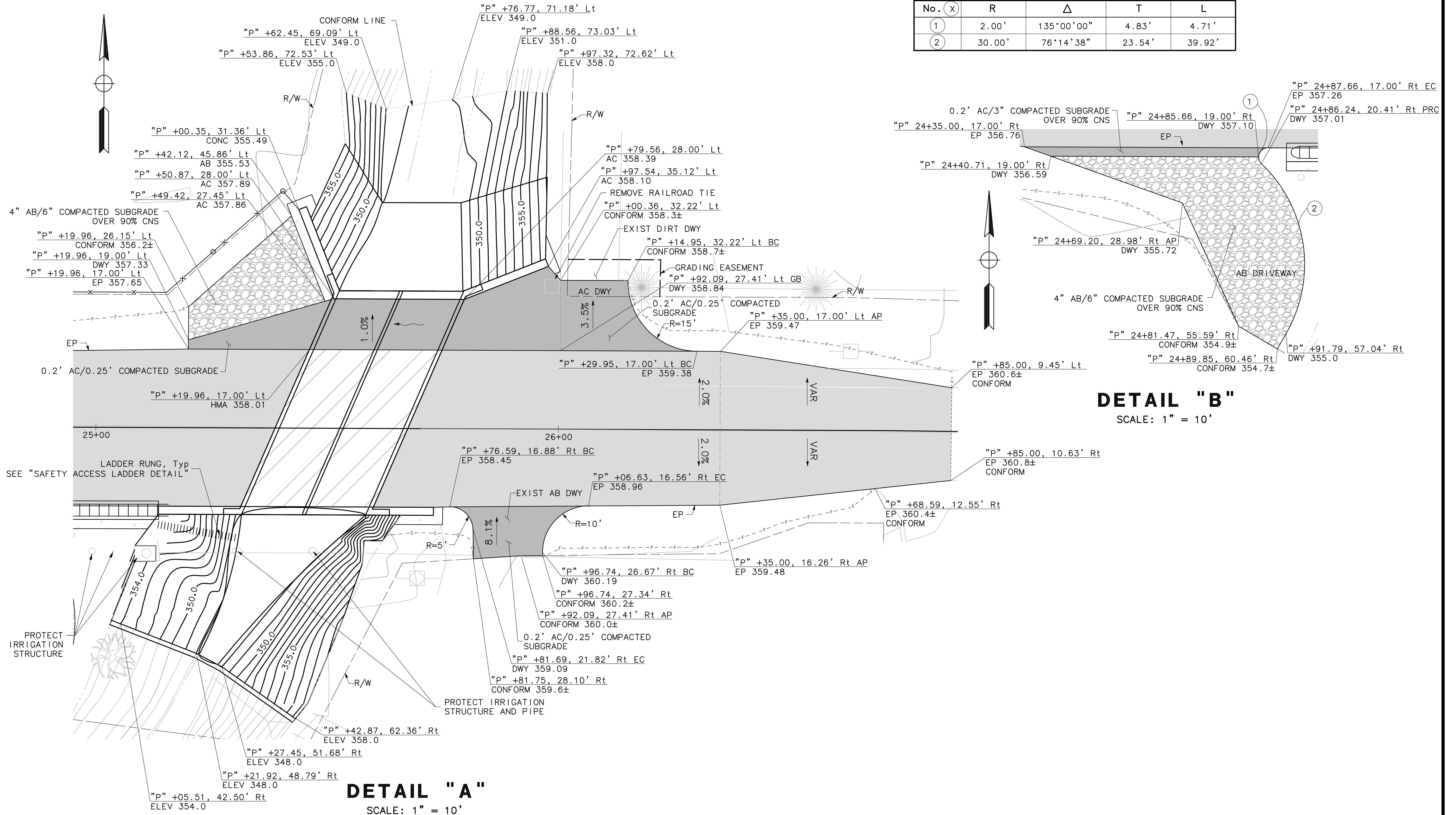

DESIGNED: CL	DATE: 04/14/2023	RECORD DRAWING	SCALE		PROJECT		DEPARTMENT OF PUBLIC WORKS AND PLANNING
DRAWN: DA	DATE: 04/14/2023	RESIDENT ENGINEER			TRAVERS CREEK AT PARLIER AVE		TRAVERS CREEK AT PARLIER AVE
CHECKED: CH	DATE: 04/14/2023		SCALE: 1" = 10'		COUNTY OF FRESNO, CA		CONSTRUCTION DETAILS
FOR RIGHT OF WAY DATA AND ACCURATE ACCESS DETERMINATION, SEE DOCUMENTS IN THE DEPARTMENT OF PUBLIC WORKS AND PLANNING.				SUPERVISING ENGINEER	ROAD NO. 6263	BRIDGE NO. 42C0684	DRAWING NO. CD-5
				DATE	SHEET NO. 33		TOTAL 40

GENERAL NOTES

1. CONCRETE LINING WILL NOTCH AROUND EXISTING CMP FOUNDATION SUPPORT.

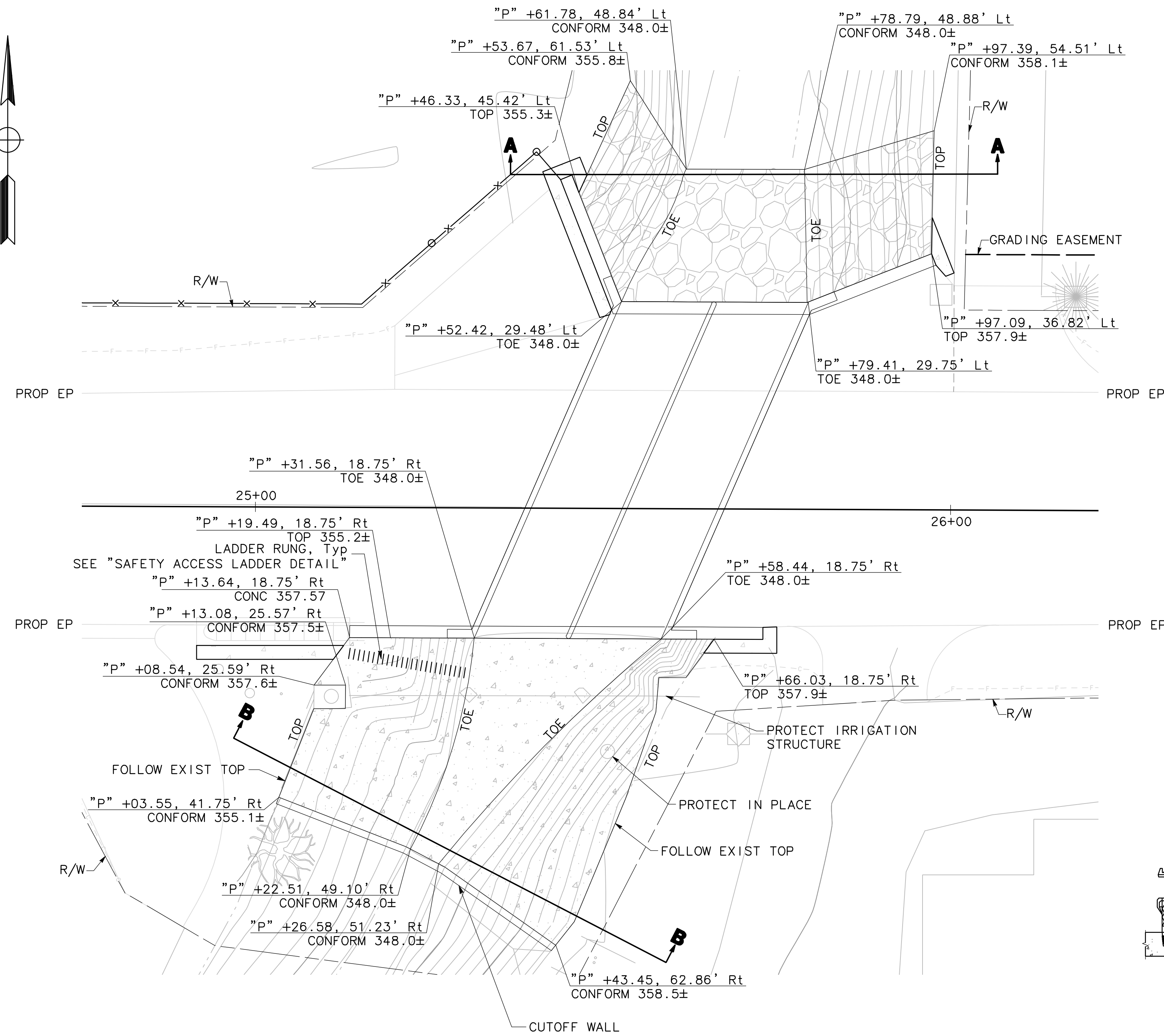
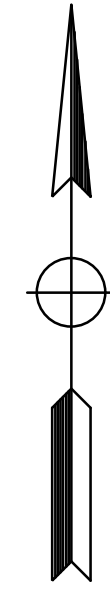

"DETAIL A"
SCALE: 1" = 10'

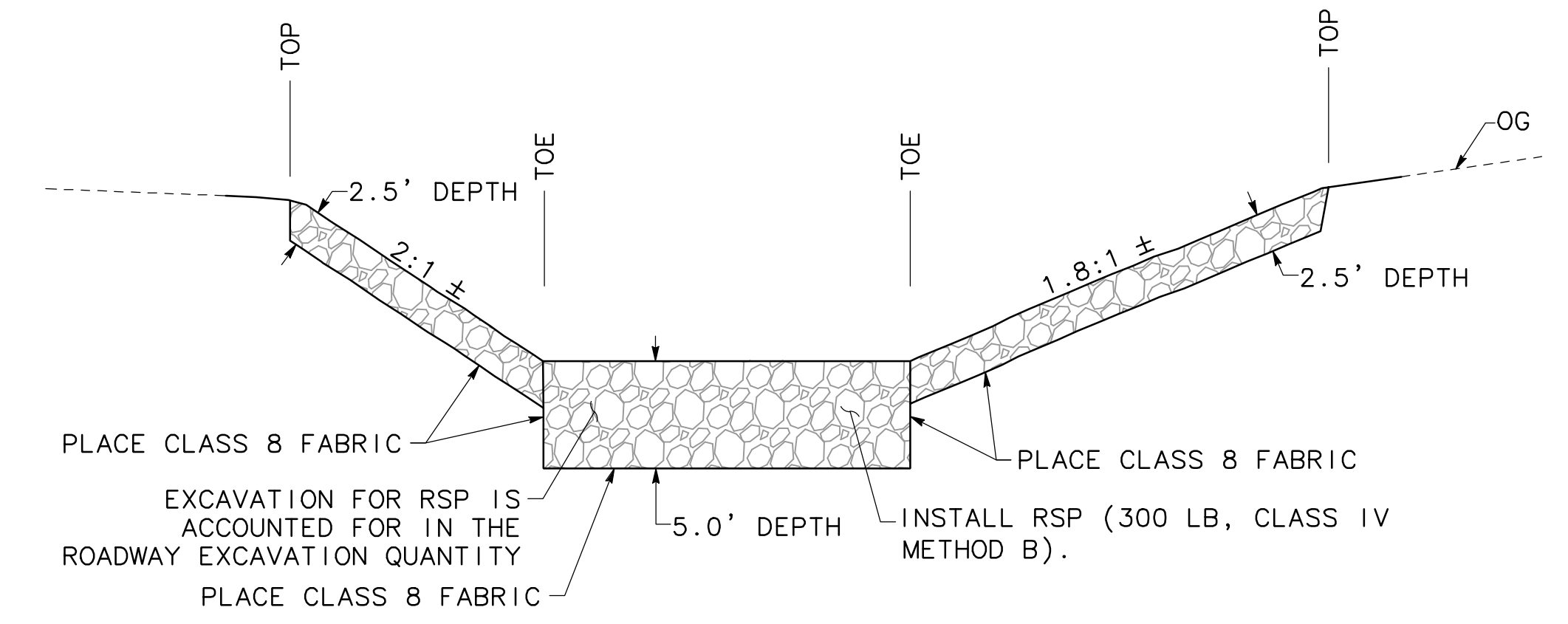

SECTION A-A
NTS

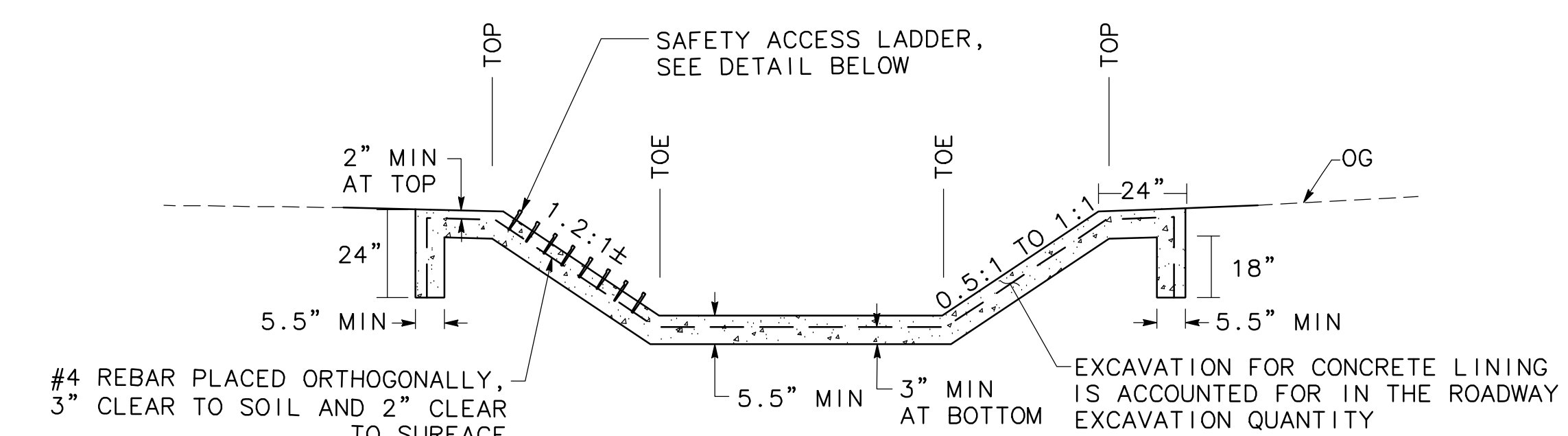

SECTION B-B
NTS

NOTE: 1) MAX SLOPE 0.5:1
2) SOILS TO HAVE 90% COMPACTION IN FILL AREAS
3) LINING CUTOFF WALLS TO BE CONSTRUCTED UPSTREAM AND DOWNSTREAM OF CONCRETE LINING

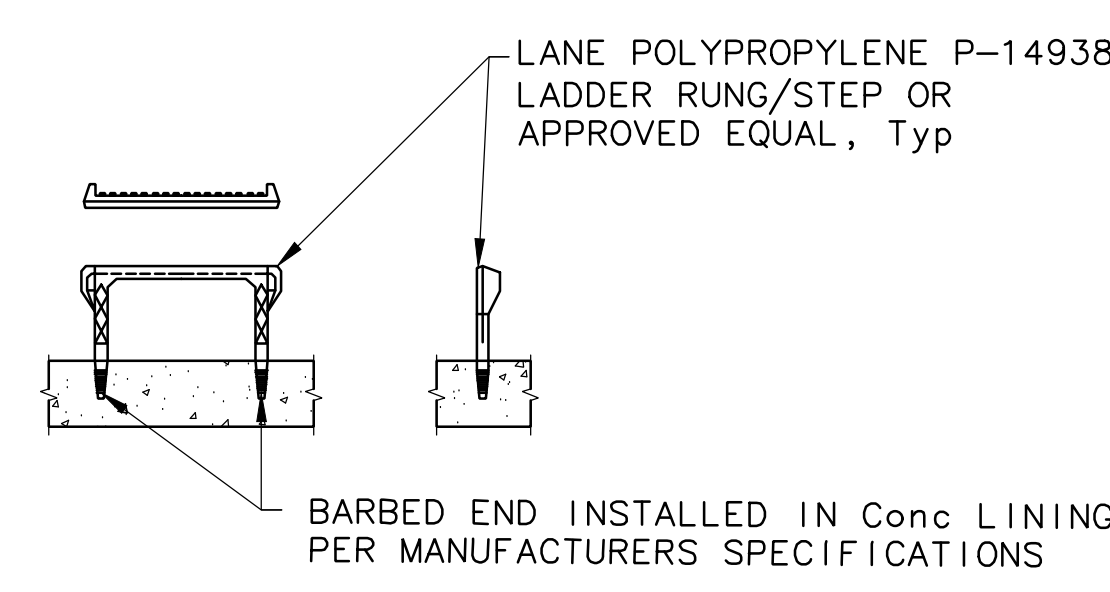

SECTION C-C
NTS

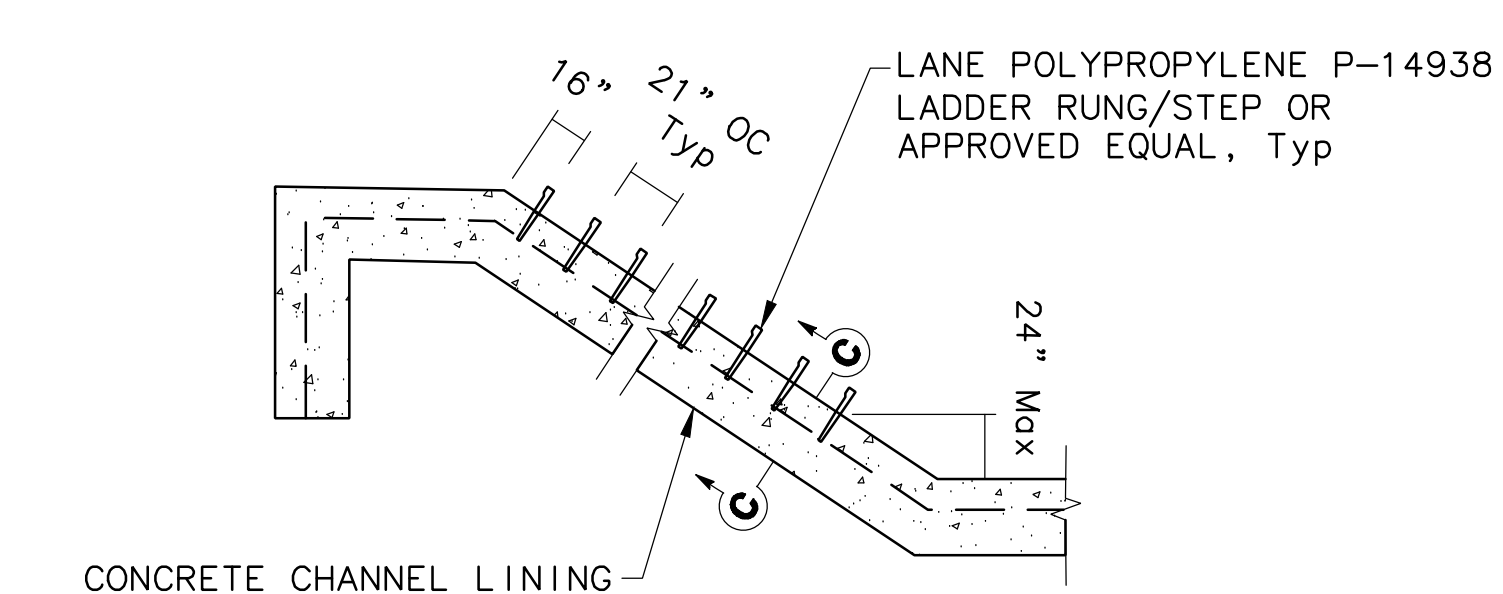

SIDE VIEW
NTS

SAFETY ACCESS LADDER DETAIL
NTS

DESIGNED: CL	DATE: 04/14/2023	RECORD DRAWING	SCALE: 1" = 10'		PROJECT		DEPARTMENT OF PUBLIC WORKS AND PLANNING
DRAWN: DA	DATE: 04/14/2023	RESIDENT ENGINEER			TRAVERS CREEK AT PARLIER AVE		TRAVERS CREEK AT PARLIER AVE
CHECKED: CH	DATE: 04/14/2023	DATE	SCALE: 1" = 10'		COUNTY OF FRESNO, CA		CONSTRUCTION DETAILS
FOR RIGHT OF WAY DATA AND ACCURATE ACCESS DETERMINATION, SEE DOCUMENTS IN THE DEPARTMENT OF PUBLIC WORKS AND PLANNING.				SUPERVISING ENGINEER	ROAD NO. 6263	BRIDGE NO. 42C0684	DRAWING NO. CD-6
				DATE	SHEET NO. 34		TOTAL 40

GENERAL NOTES

LOCATIONS FOR EXISTING UNDERGROUND FACILITIES ARE APPROXIMATE. EXACT DEPTH AND LOCATIONS ARE UNKNOWN. FIELD LOCATE PRIOR TO THE START OF CONSTRUCTION.

**CALL UNDERGROUND SERVICE ALERT (USA) 811

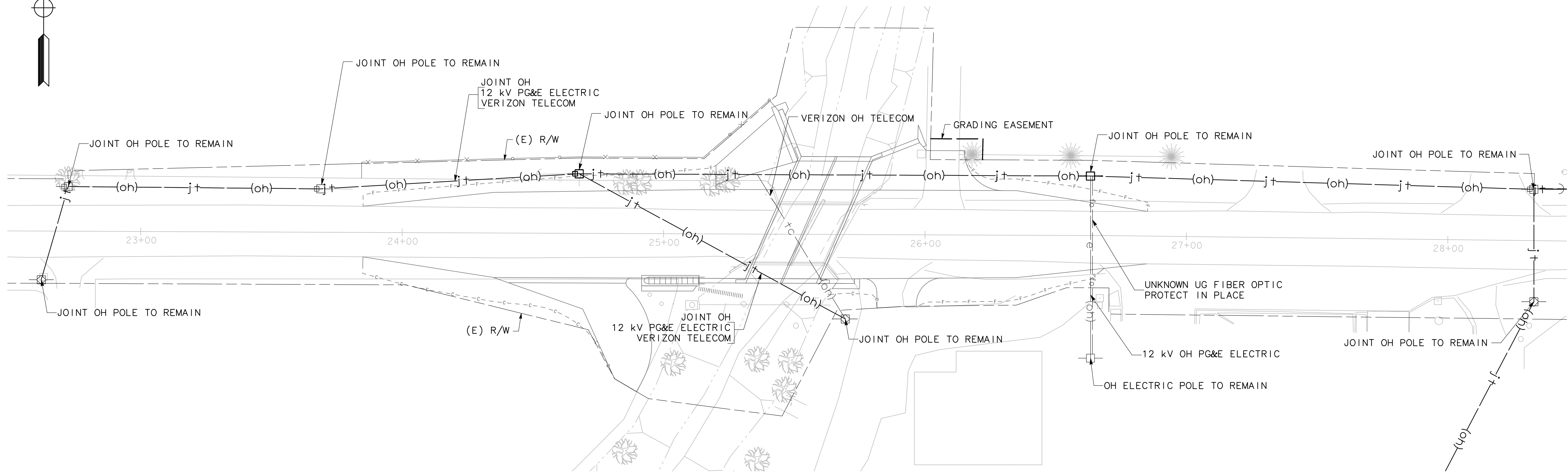
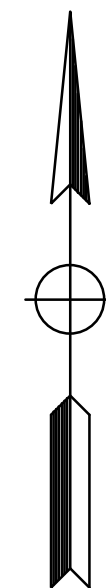

PARLIER AVENUE
SCALE: 1" = 20'

DESIGNED: CL	DATE: 04/14/2023	RECORD DRAWING		SCALE		PROJECT		DEPARTMENT OF PUBLIC WORKS AND PLANNING		
DRAWN: DA	DATE: 04/14/2023	RESIDENT ENGINEER	DATE	0 10 20 40		TRAVERS CREEK AT PARLIER AVE		TRAVERS CREEK AT PARLIER AVE		
CHECKED: CH	DATE: 04/14/2023			SCALE: 1" = 20'		COUNTY OF FRESNO, CA		UTILITY PLAN		
FOR RIGHT OF WAY DATA AND ACCURATE ACCESS DETERMINATION, SEE DOCUMENTS IN THE DEPARTMENT OF PUBLIC WORKS AND PLANNING.					SUPERVISING ENGINEER	ROAD NO. 6263	BRIDGE NO. 42C0684	DRAWING NO. U-3	SHEET NO. 35	TOTAL 40

GENERAL NOTES

1. WORK SHALL BE DONE IN ACCORDANCE WITH THE 2015 STANDARD PLANS AND SPECIFICATIONS OF THE STATE OF CALIFORNIA DEPARTMENT OF TRANSPORTATION, SIGN SPECIFICATION SHEETS, THE 2014 CALIFORNIA MANUAL ON UNIFORM TRAFFIC CONTROL DEVICES (CA MUTCD), AND THE SPECIAL PROVISIONS.
2. THESE SIGNING AND STRIPING PLANS ARE ACCURATE FOR SIGNING AND PAVEMENT MARKINGS ONLY. ALL REFERENCE TO PAVEMENT MARKINGS SHALL INCLUDE STRIPING.
3. ALL SALVAGED MATERIAL SHALL BE DELIVERED TO THE COUNTY SIGN SHOP (BUILDING 409) AT 4551 e. HAMILTON AVENUE. THE CONTRACTOR SHALL NOTIFY THE SIGN SHOP (559)600-7899 AT LEAST TWO WORKING DAYS PRIOR TO DELIVERY.
4. ALL EXISTING PAVEMENT MARKING WHICH CONFLICTS WITH PROPOSED PAVEMENT MARKING SHALL BE REMOVED.
5. EXISTING PAVEMENT MARKINGS TO BE REMOVED SHALL BE DONE BY GRINDING. AFTER GRINDING, A PARKING AREA SEAL SHALL BE APPLIED TO THE AREA.
6. ALL PAVEMENT MARKINGS SHALL BE THERMOPLASTIC.
7. ALL EXISTING SIGNS NOT SHOWN ON THE PLANS TO REMAIN OR BE RELOCATED SHALL REMAIN, BE SALVAGED, OR RELOCATED AS DIRECTED BY THE ENGINEER.
8. SIGNS SHALL BE TYPE iv OR ix RETROREFLECTIVE SHEETING IN ACCORDANCE WITH ASTM 4956-09. ALL SIGNS SHALL BE COVERED WITH A TRANSLUCENT ANTI-GRAFFITI FLUOROPOLYMER FILM THAT DOES NOT IMPAIR THE REFLECTIVITY OF THE SIGN.

LEGEND:

- I INSTALL TRAFFIC SIGN. TEXT INDICATES CA MUTCD SIGN CODE
- # DENOTES DETAIL NUMBER PER CALTRANS STANDARD PLAN
- ↑ PROPOSED SINGLE POST ROADSIDE SIGN
- EXISTING SIGN TO BE REMOVED
- //// REMOVE YELLOW TRAFFIC STRIPE (HAZARDOUS WASTE)

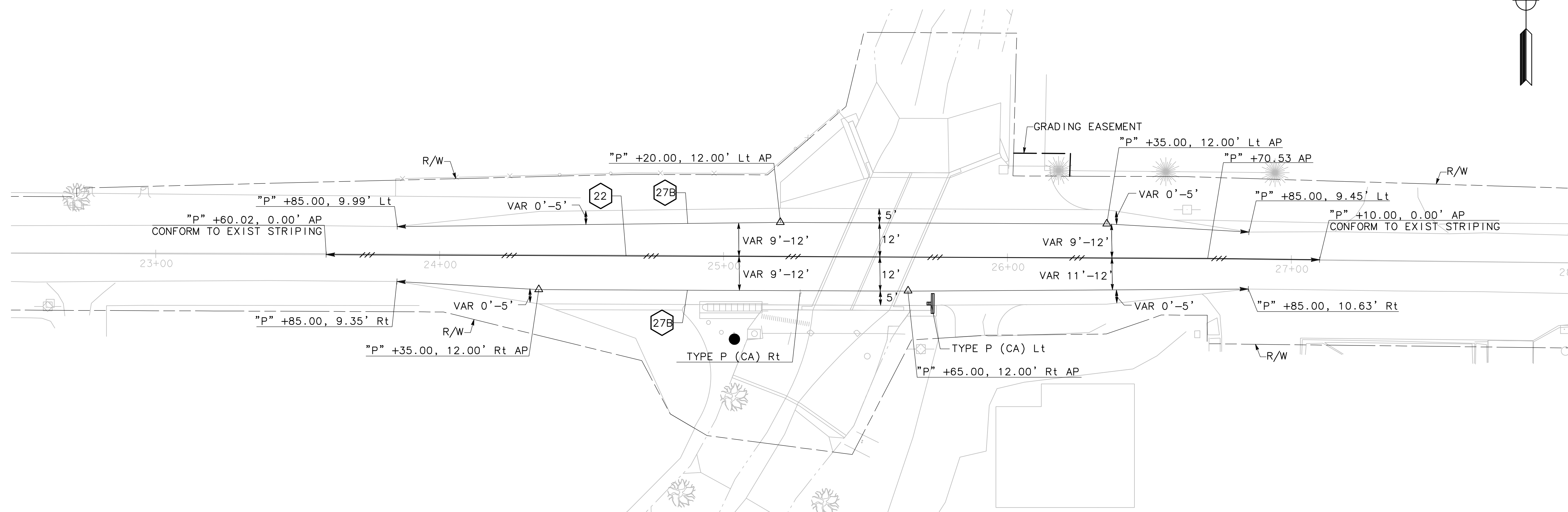
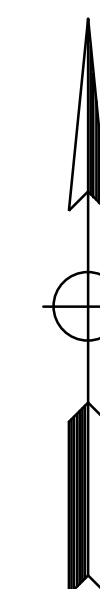

PARLIER AVENUE
SCALE: 1" = 20'

DESIGNED: CL		DATE: 04/14/2023	RECORD DRAWING		SCALE		PROJECT		DEPARTMENT OF PUBLIC WORKS AND PLANNING	
DRAWN: DA		DATE: 04/14/2023	RESIDENT ENGINEER		0 10 20 40		TRAVERS CREEK AT PARLIER AVE		TRAVERS CREEK AT PARLIER AVE	
CHECKED: CH		DATE: 04/14/2023			SCALE: 1" = 20'		COUNTY OF FRESNO, CA		SIGNING AND STRIPING PLAN	
							ROAD NO. 6263		DRAWING NO. SS-3	
							BRIDGE NO. 42C0684		SHEET NO. 36	
									TOTAL 40	

FOR RIGHT OF WAY DATA AND ACCURATE ACCESS DETERMINATION, SEE DOCUMENTS IN THE DEPARTMENT OF PUBLIC WORKS AND PLANNING.

STATIONARY MOUNTED CONSTRUCTION AREA SIGNS

SIGN LETTER	SIGN CODE	PANEL SIZE	SIGN MESSAGE	EACH (N)
(A)	M4-8A	24" x 18"	END DETOUR	2
(B)	M4-9(L)	30" x 24"	DETOUR WITH ARROW (LEFT)	7
(C)	M4-9(R)	30" x 24"	DETOUR WITH ARROW (RIGHT)	5
(D)	M4-10(R)	48" x 18"	DETOUR ARROW (RIGHT)	2
(E)	R3-1	24" x 24"	NO RIGHT TURN SYMBOL	2
(F)	R11-2	48" x 30"	ROAD CLOSED	2
(G)	R11-4	60" x 30"	ROAD CLOSED TO THRU TRAFFIC	2
(H)	SC3(CA)	36" x 12"	DETOUR WITH ARROW (STRAIGHT)	9
(I)	W20-1	36" x 36"	ROAD WORK AHEAD	2
(J)	W20-3	36" x 36"	ROAD CLOSED AHEAD	2
(K)	R3-2	24" x 24"	NO LEFT TURN SYMBOL	1
(L)	CUSTOM	54" x 36"	EB PARLIER AVE CLOSED FOLLOW DETOUR	3
(M)	CUSTOM	54" x 36"	WB PARLIER AVE CLOSED FOLLOW DETOUR	2
(N)	CUSTOM	54" x 36"	WB PARLIER AVENUE CLOSED TO THRU TRAFFIC	2
TOTAL				43

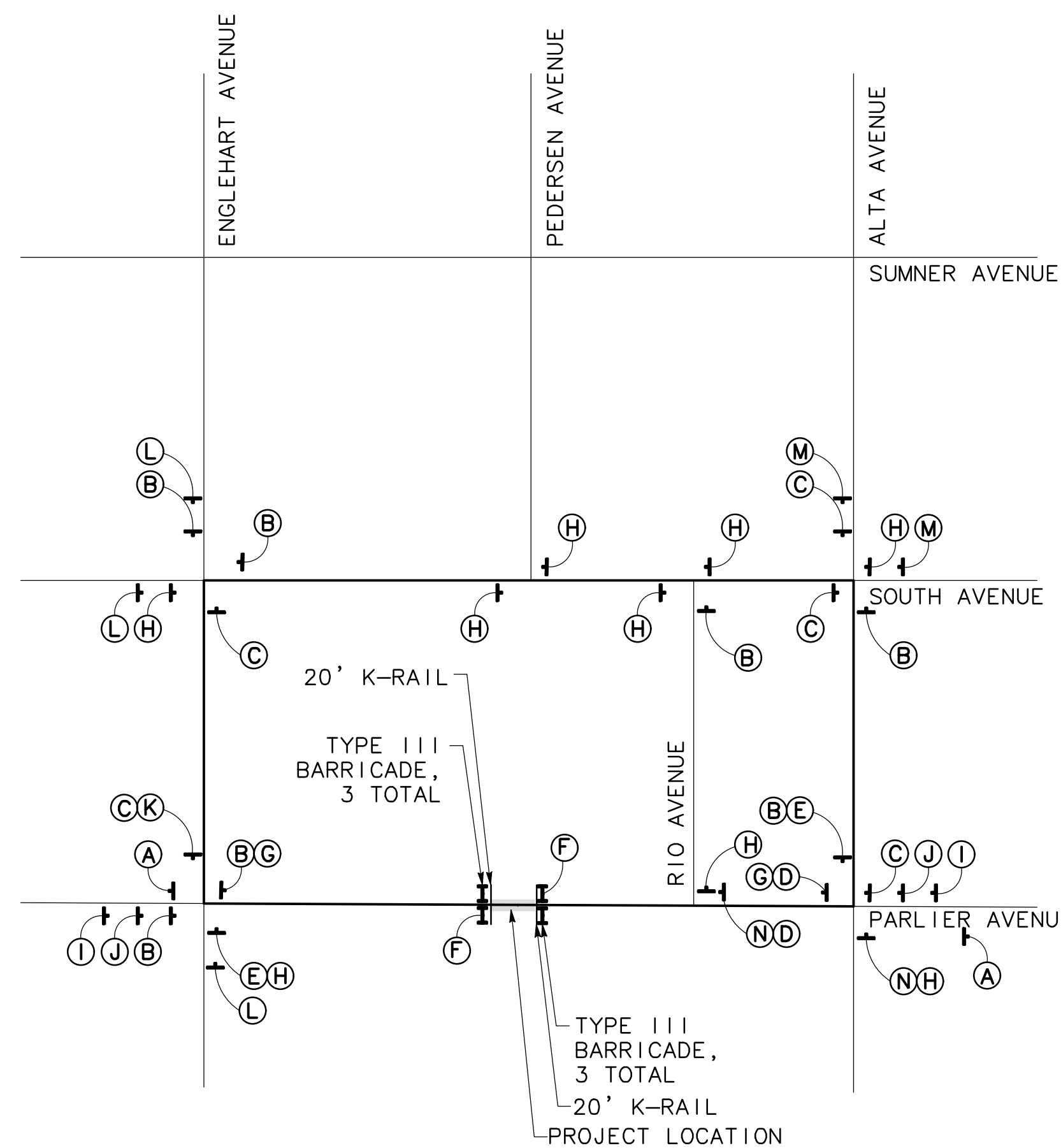

GENERAL NOTES

1. LOCATION OF CONSTRUCTION AREA/DETOUR SIGNS SHOWN ARE APPROXIMATE. EXACT SIGN LOCATION IS TO BE DETERMINED BY THE ENGINEER.
2. ALL TRAFFIC CONTROL DEVICES, BARRIERS, SIGNS, PAVEMENT MARKINGS, AND CHANNELIZATION DEVICES SHALL CONFORM TO THE MOST RECENT VERSION OF THE CA MUTCD.
3. FOR SIGN SPACING, REFER TO 2014 CA MUTCD (REV 2) TABLE 6H-3. REFER 2014 CA MUTCD FOR MEANING OF LETTER CODES ON TYPICAL APPLICATION DIAGRAMS.
4. CONTRACTOR TO PROVIDE REASONABLE MEANS FOR PROPERTY OWNERS ADJACENT CONSTRUCTION TO ACCESS PROPERTIES AT ALL TIMES.
5. CONTRACTOR TO COORDINATE ANY DRIVEWAY CLOSURES WITH PROPERTY OWNERS BEFORE REMOVING ACCESS.

	DATE	RECORD DRAWING	SCALE			PROJECT		<i>DEPARTMENT OF PUBLIC WORKS AND PLANNING</i>
DESIGNED: CL	04/14/2023	RESIDENT ENGINEER	0 500 1000 2000 SCALE: 1" = 1000'	_____ SUPERVISING ENGINEER	_____ DATE	TRAVERS CREEK AT PARLIER AVE COUNTY OF FRESNO, CA		TRAVERS CREEK AT PARLIER AVE TRAFFIC DETOUR PLAN
DRAWN: DA	04/14/2023					ROAD NO. 6263	BRIDGE NO. 42C0684	DRAWING NO. TD-3
CHECKED: CH	04/14/2023							SHEET NO. 37
FOR RIGHT OF WAY DATA AND ACCURATE ACCESS DETERMINATION, SEE DOCUMENTS IN THE DEPARTMENT OF PUBLIC WORKS AND PLANNING.								TOTAL 40

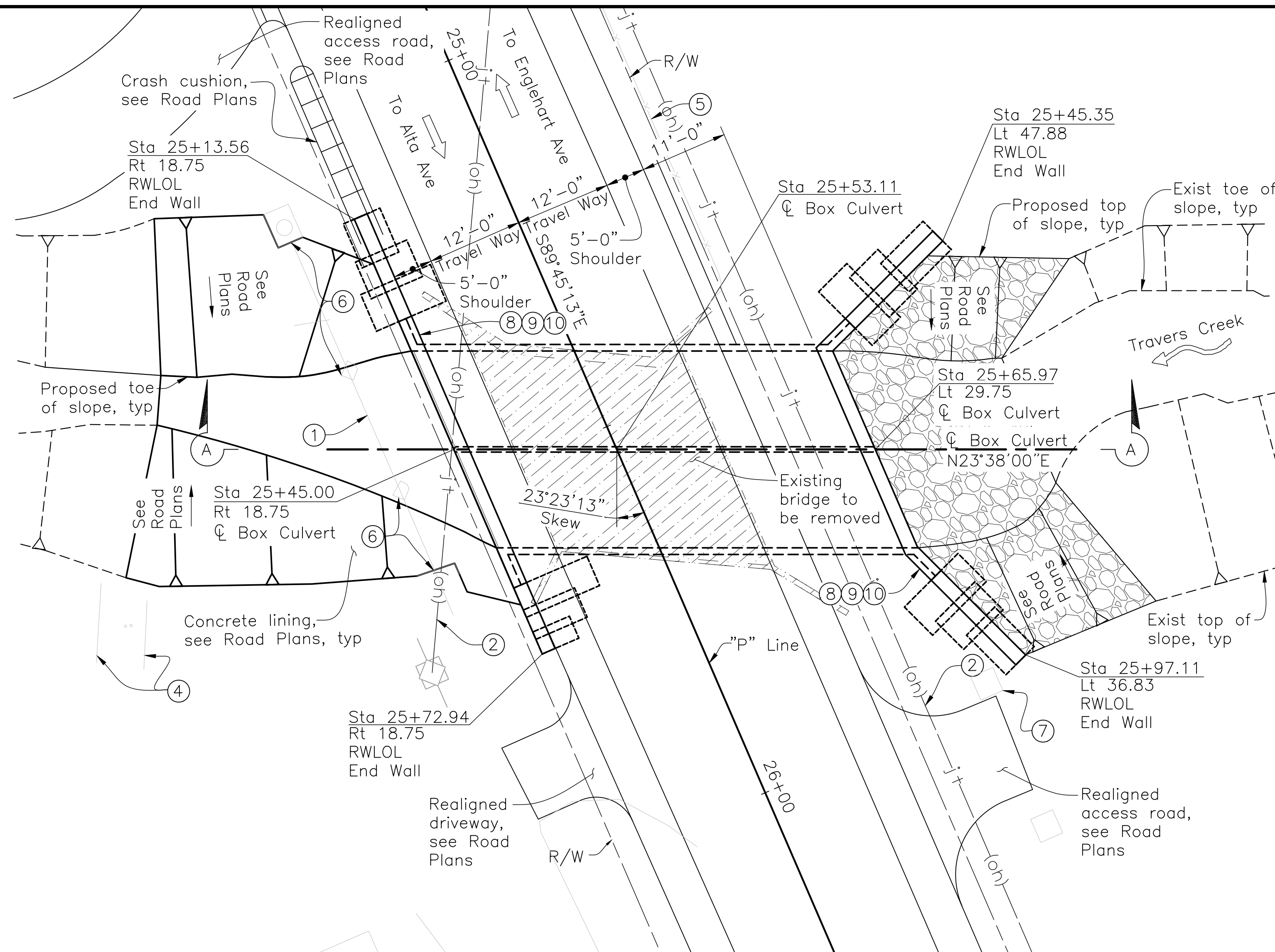

- Legend:**
- RWLOL Indicates retaining wall layout line
 - R/W Indicates right of way
 - ① Existing 18" CMP irrigation line to remain
 - ② Existing overhead joint electricity & telephone line to be relocated
 - ③ Existing overhead telephone line to be remain
 - ④ Existing propane tanks to remain
 - ⑤ Existing guy wire to be relocated
 - ⑥ Existing concrete utility support to remain
 - ⑦ Existing railroad ties to be removed, see Road Plans
 - ⑧ Paint "Travers Creek"
 - ⑨ Paint "State Br. No. 42C0684"
 - ⑩ Paint "County Br. No. 10-099"
 - Indicates direction of traffic
 - x-x Existing guy wire to be relocated
 - [Hatched Box] Indicates existing structure to be removed
 - [Rock Pattern] Indicates rock slope protection, see Road Plans
 - [Cross-hatched Box] Indicates lean concrete or crushed gravel backfill
 - [Diagonal Hatched Box] Indicates asphalt concrete overlay
 - ⊙ B0-3 3-2 Indicates Caltrans Standard Plan sheet no.
 - ⊙ 3-2 Indicates detail no.

PLAN
1"=10'-0"

Note:
1. For "Detail Y" see BOX CULVERT DETAILS sheet

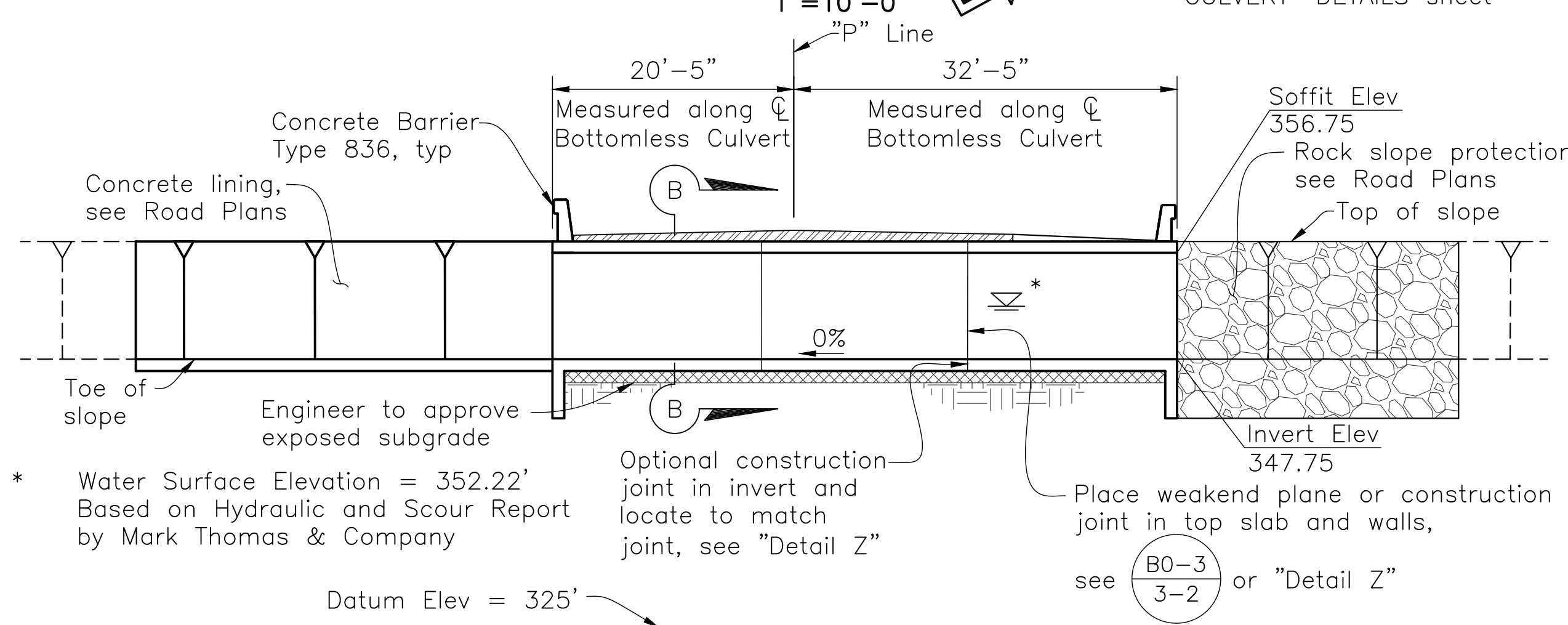

LONGITUDINAL SECTION A-A
1"=10'-0"

Notes:
1. For "Section B-B" see BOX CULVERT DETAILS sheet
2. For "Detail Z" see BOX CULVERT DETAILS sheet

DESIGNED_MAW DRAWN_TZE CHECKED_JPJ	DATE 11/10/17 11/10/17 11/10/17	Scale AS SHOWN	CORNERSTONE structural engineering group 986 W Alluvial Ave - Suite 201 Fresno, California 93711 559.320.3200 fax 559.320.3201		PROJECT TRIVERS CREEK AT PARIER AVE COUNTY OF FRESNO, CA Road No. 6263 Bridge No. 42C0684		DEPARTMENT OF PUBLIC WORKS & PLANNING TRIVERS CREEK AT PARIER AVE GENERAL LAYOUT Drawing No. S-12 Sheet No. 38 of 40
--	--	-------------------	--	--	--	--	--

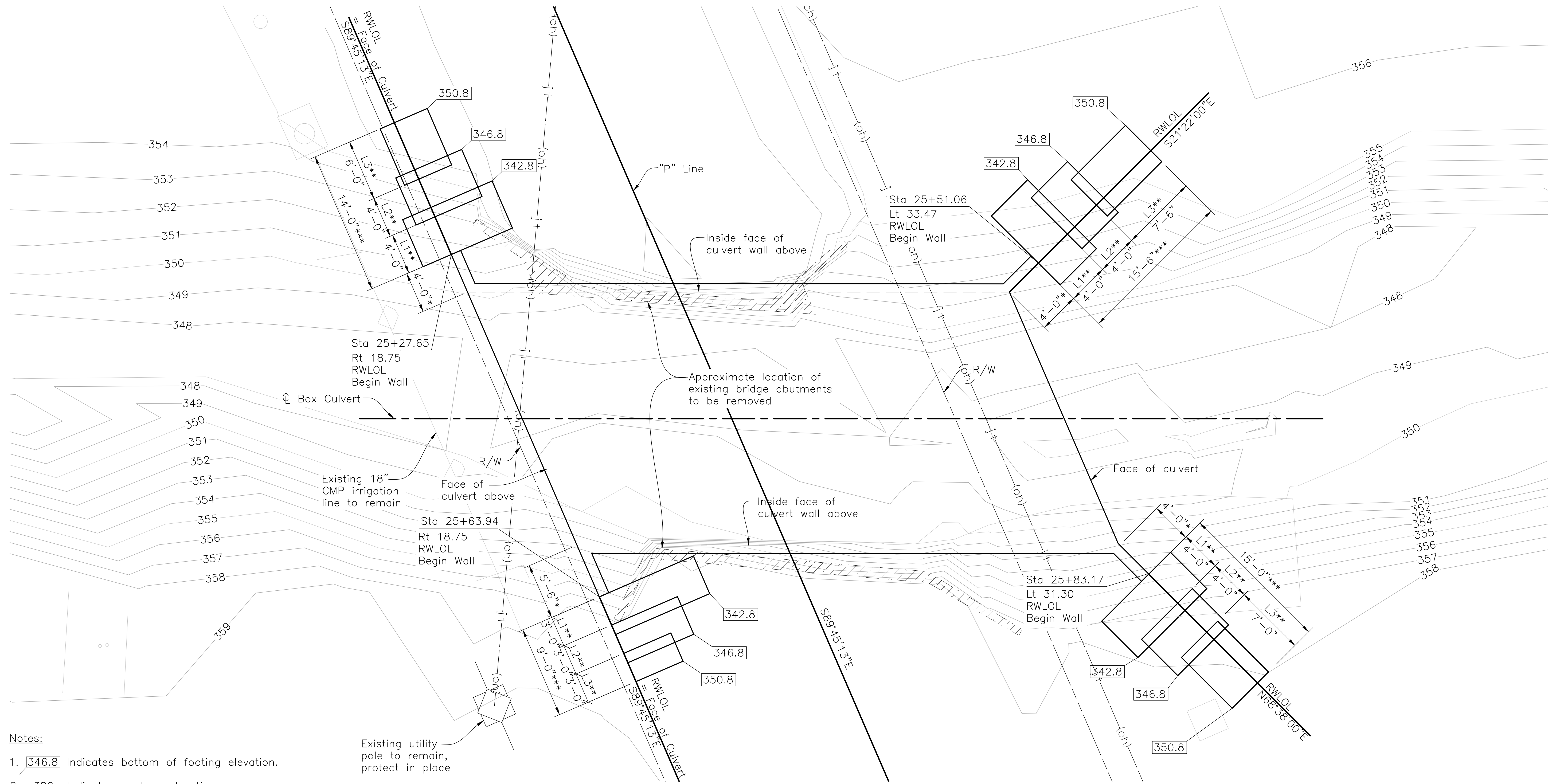

- Notes:
1. 346.8 Indicates bottom of footing elevation.
 2. -380- Indicates contour elevation.
 3. [Hatched Box] Indicates existing structure to be removed.
 4. Contractor shall verify all existing controlling field dimensions before ordering or fabricating any material.
 5. Contours shown indicate existing conditions. For finished grade limits, see Road Plans.
 6. * Indicates length of headwall measured along RWLWL, see "Section D-D" on BOX CULVERT DETAILS sheet.
 7. ** See "Retaining Wall Elevation" on BOX CULVERT DETAILS sheet.
 8. *** Indicates length of retaining wall measured along RWLWL.

PLAN
1"=5'-0"

DESIGNED_MAW	DATE 11/10/17
DRAWN_TZE	11/10/17
CHECKED_JPJ	11/10/17

Scale	AS SHOWN
-------	----------

CORNERSTONE
structural engineering group

986 W Alluvial Ave - Suite 201
Fresno, California 93711
559.320.3200
fax 559.320.3201

FOR R/W DATA AND ACCURATE ACCESS DETERMINATION SEE R/W RECORDS AT PUBLIC WORKS

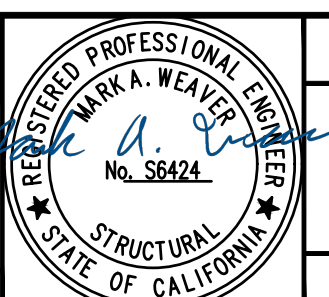

PROJECT	TRAVERS CREEK AT PARIER AVE COUNTY OF FRESNO, CA
Road No. 6263	Bridge No. 42C0684



DEPARTMENT OF PUBLIC WORKS & PLANNING
TRAVERS CREEK AT PARIER AVE FOUNDATION PLAN
Drawing No. S-13 Sheet No. 39 of 40

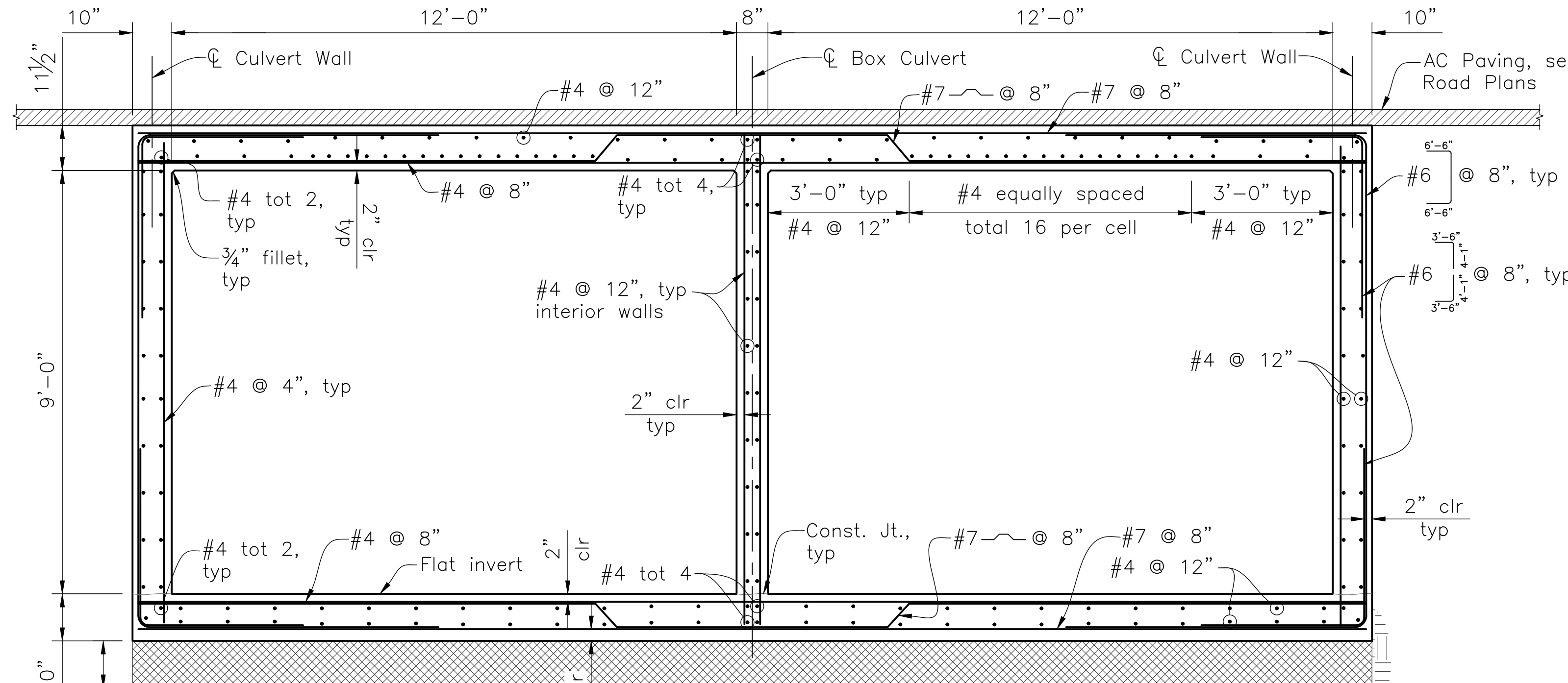

SECTION B-B
1/2" = 1'-0"

Note:
For details not shown, see (D81)

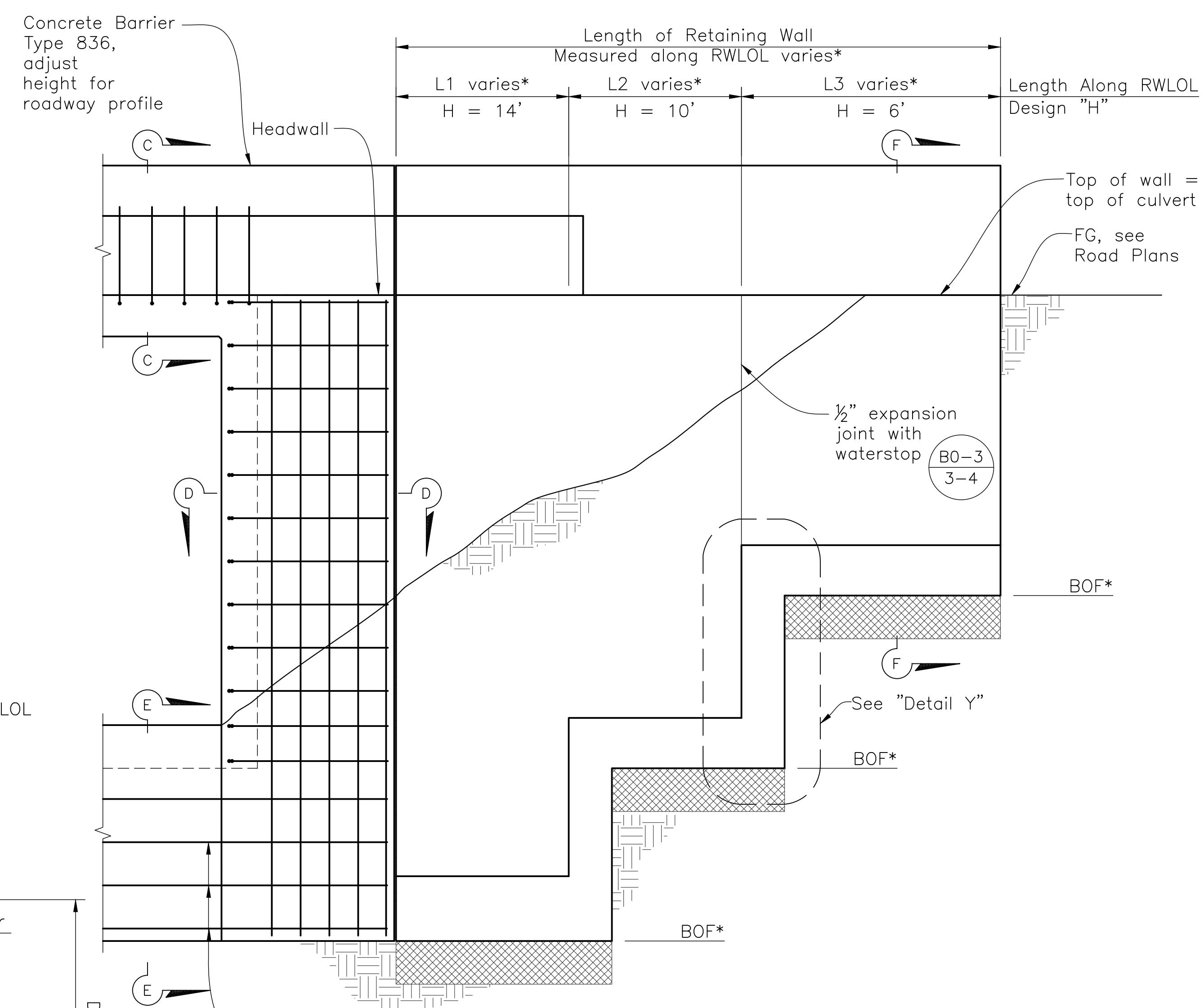

RETAINING WALL ELEVATION
1/2" = 1'-0"

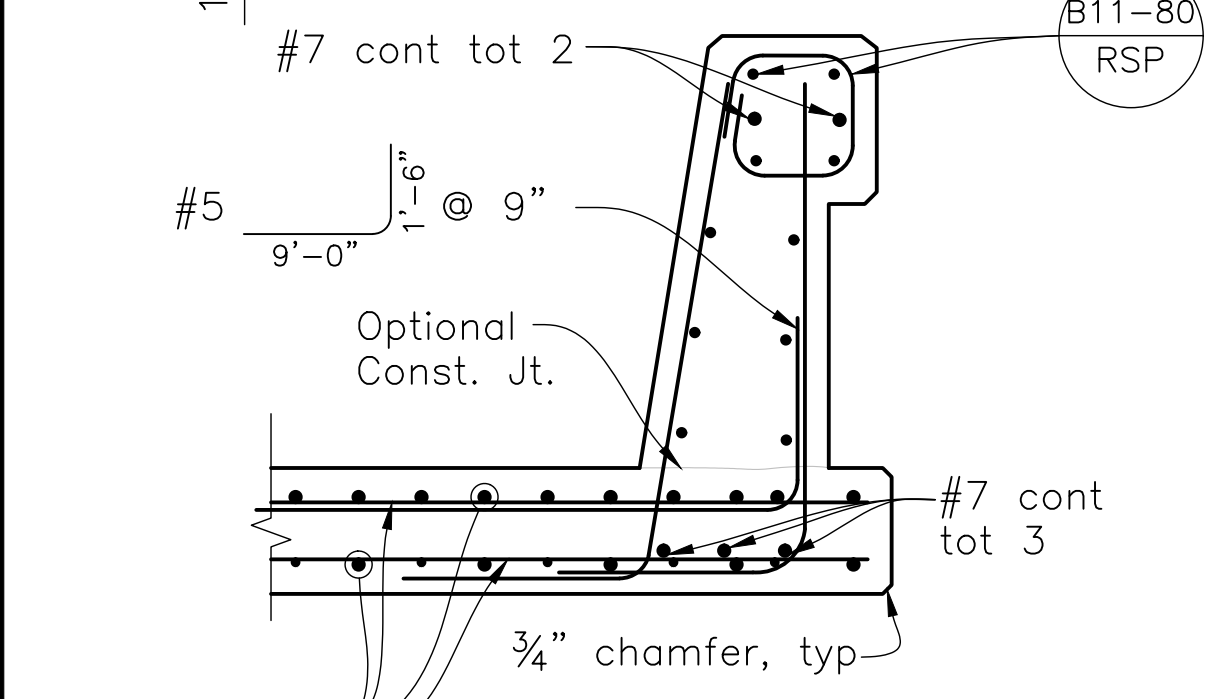

SECTION C-C
3/4" = 1'-0"

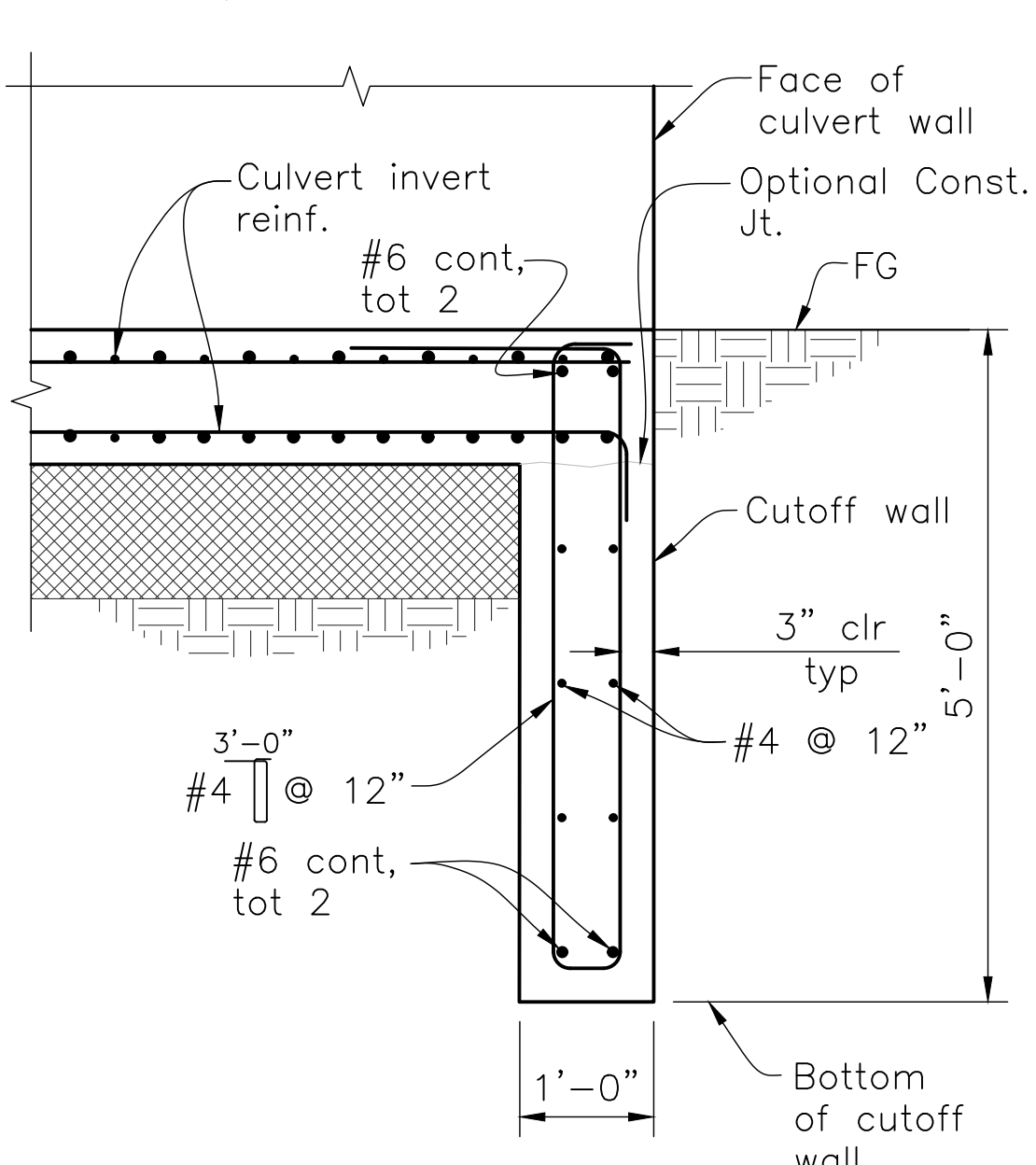

SECTION E-E
3/4" = 1'-0"

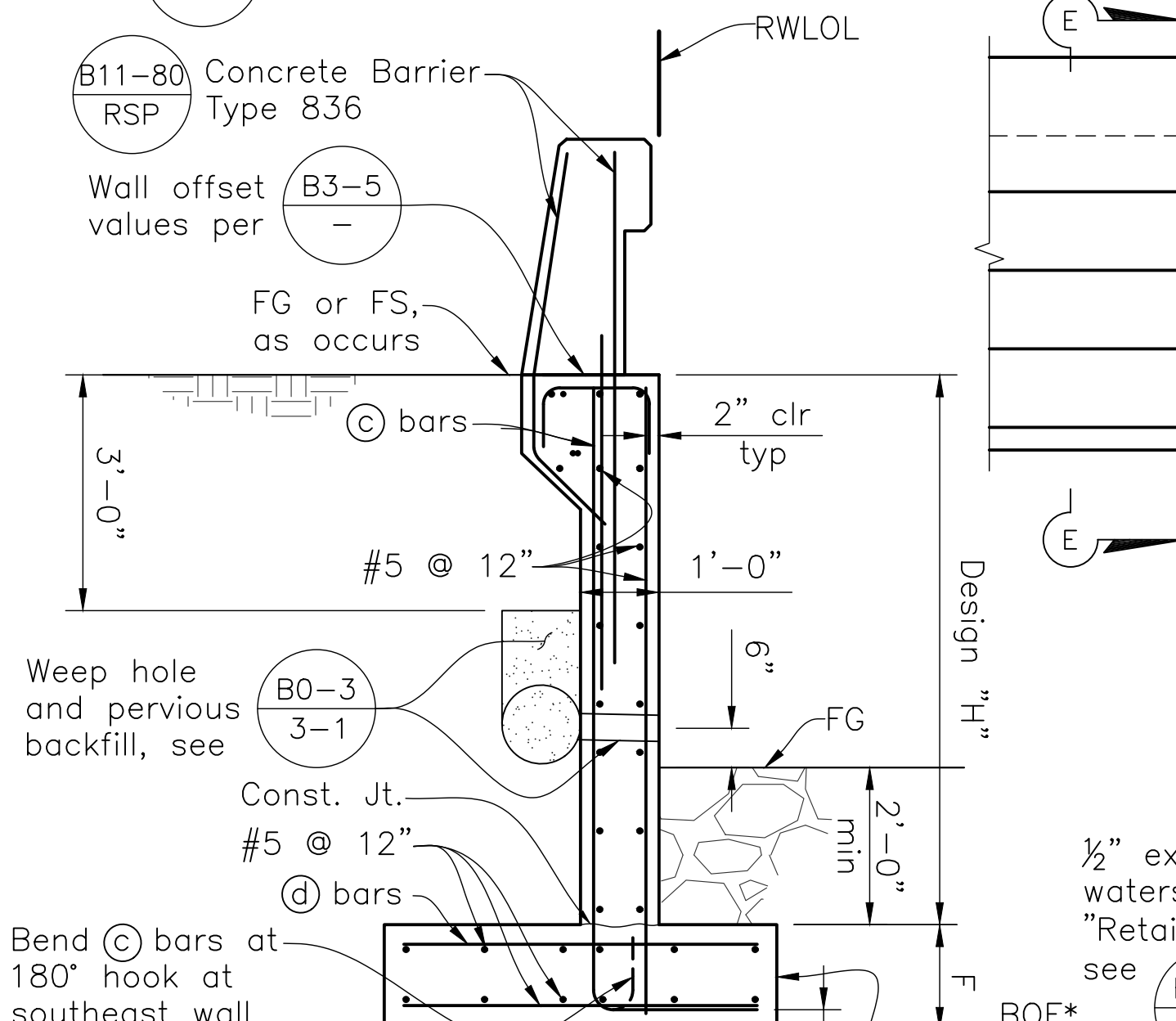

"H"	6'	10'	14'	"H"	6'	10'	14'
B	3'-6"	5'-0"	6'-6"	B	5'-0"	7'-0"	10'-0"
C	1'-6"	2'-0"	3'-0"	C	0'-0"	0'-0"	0'-0"
W	5'-0"	7'-0"	9'-6"	W	5'-0"	7'-0"	10'-0"
F	1'-2"	1'-2"	1'-6"	F	1'-2"	1'-2"	2'-3"
ⓐ	#6@4"	#7@4"	#8@5"	ⓐ	#6@4"	#7@4"	#8@5"
ⓑ	#6@8"	#7@8"	#8@10"	ⓑ	#6@8"	#7@8"	#8@5"

SECTION F-F
1/2" = 1'-0"

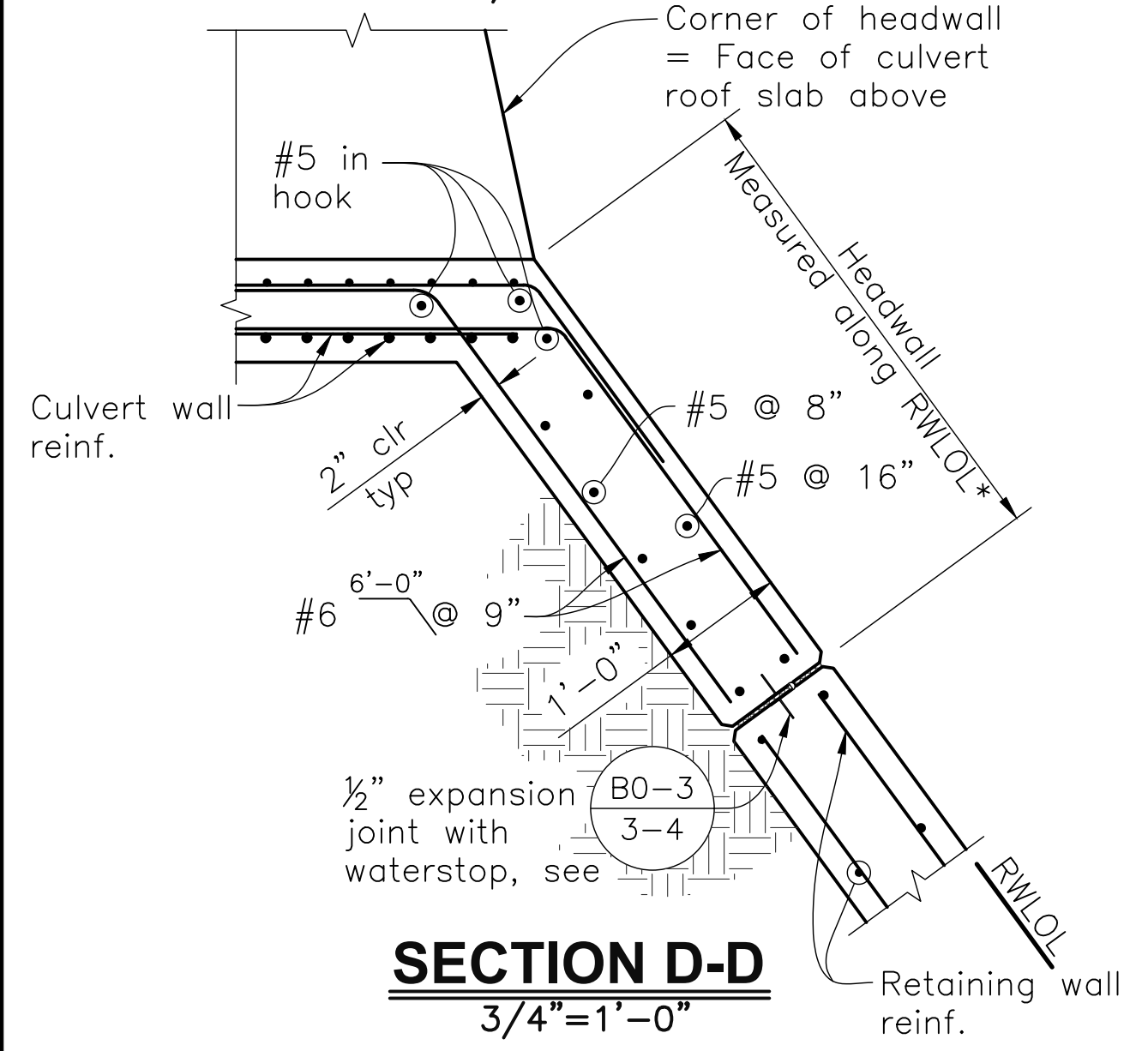

SECTION D-D
3/4" = 1'-0"

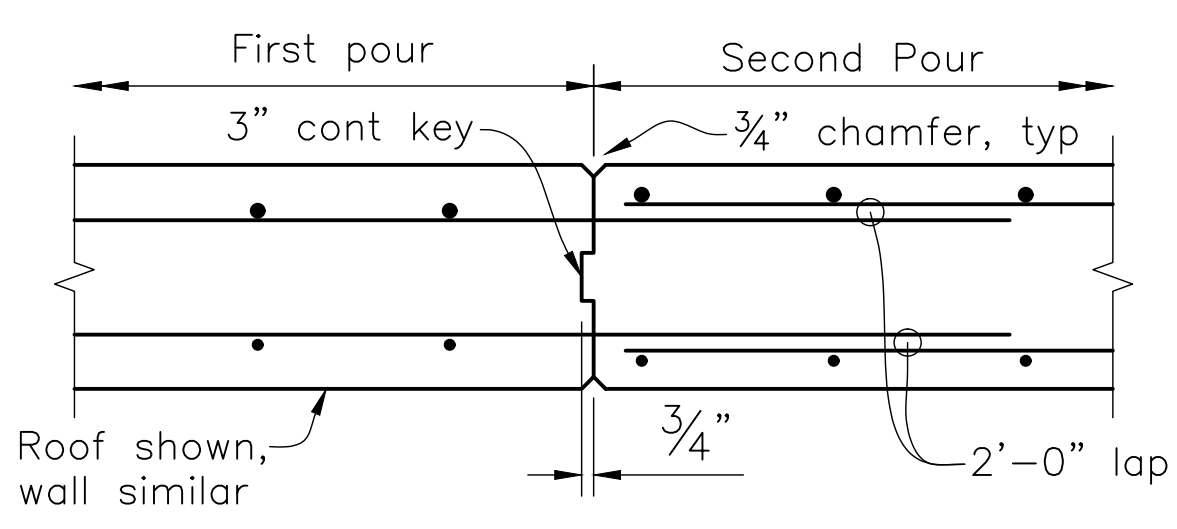

DETAIL Z
1" = 1'-0"

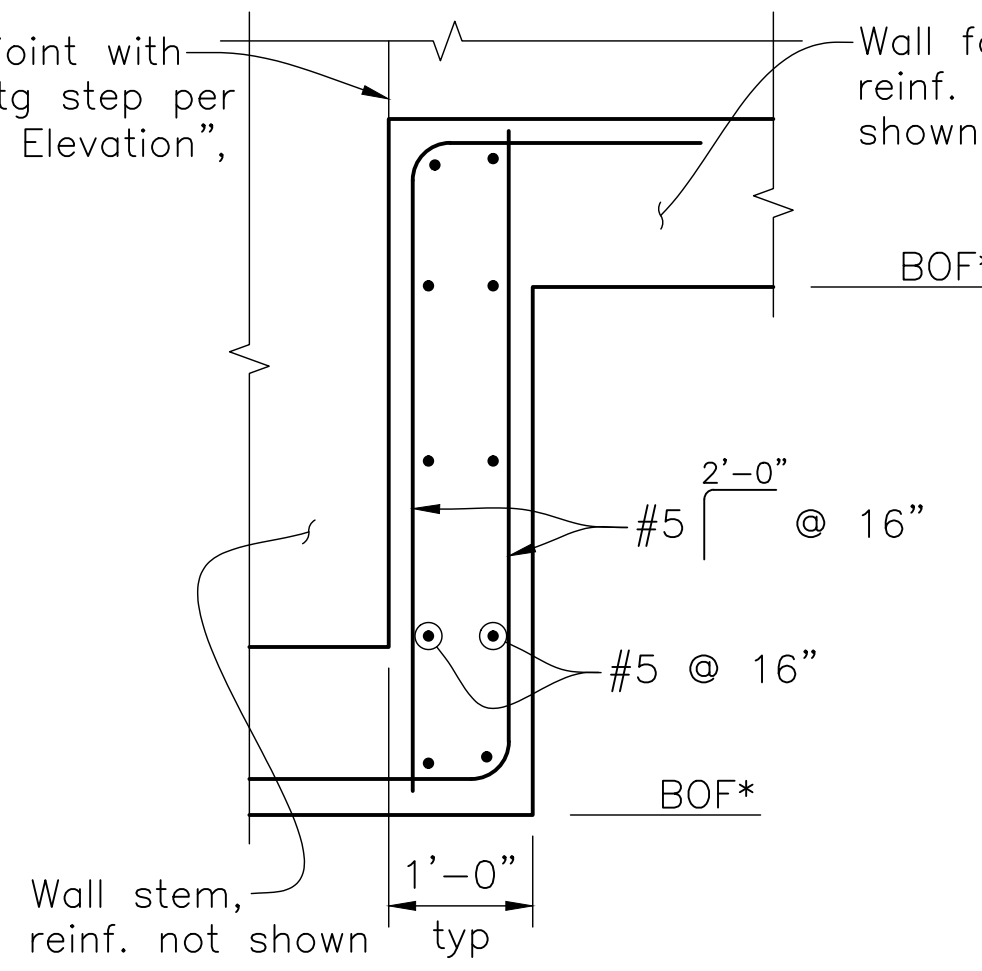

DETAIL Y
3/4" = 1'-0"

- General Notes:**
- * See FOUNDATION PLAN sheet
 - BOF Indicates bottom of footing elevation
 - RWLOL Indicates retaining wall layout line
 - (Symbol) Indicates rip-rap, see Road Plans
 - (Symbol) Indicates lean concrete or crushed gravel backfill

DESIGNED_MAW	DATE 11/10/17
DRAWN_TZE	11/10/17
CHECKED_JPJ	11/10/17
REVISION	

Scale
AS SHOWN

CORNERSTONE
structural engineering group
986 W Alluvial Ave - Suite 201
Fresno, California 93711
559.320.3200
fax 559.320.3201

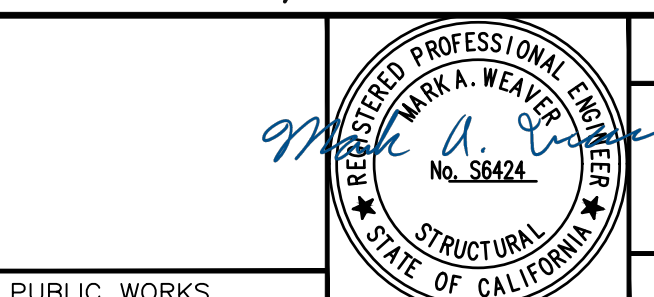

PROJECT
TRAVERS CREEK AT PARLIER AVE
COUNTY OF FRESNO, CA
Road No. 6263 Bridge No. 42C0684



DEPARTMENT OF PUBLIC WORKS & PLANNING
TRAVERS CREEK AT PARLIER AVE
BOX CULVERT DETAILS
Drawing No. S-14 Sheet No. 40 of 40